

A Statistical Identification Approach by the Boundary Field Changes

Rumena D. Stancheva, Ilona I. Iatcheva

Abstract—In working mode some unexpected changes could be arise in inner structure of electromagnetic device. They influence modification in electromagnetic field propagation map. The field values at an observed boundary are also changed. The development of the process has to be watched because the arising structural changes would provoke the device to be gone out later. The probabilistic assessment of the state is possible to be made. The numerical assessment points if the resulting changes have only accidental character or they are due to the essential inner structural disturbances.

The presented application example is referring to the 200MW turbine-generator. A part of the stator core end teeth zone is simulated broken. Quasi three-dimensional electromagnetic and temperature field are solved applying FEM. The stator core state diagnosis is proposed to be solved as an identification problem on the basis of a statistical criterion.

Keywords—Identification, structural disturbance, statistical criterion.

I. INTRODUCTION

IN stationary modes suddenly arising changes of the field values could be due to undesired inner structural deformations, the details or part of them breakings, as well as unexpected non-homogenous formations appearing in homogenous medium. Such effects are possible in electromagnetic devices through real incidents as [1]: deformations in axial direction of stator core teeth, the tooth or part of it breaking in large alternating current electrical machines and the last mentioned case is for example typical for the cooling oil in the transformer. Similar defects modify electromagnetic field propagation map inner and at the field boundary. Because of the uniqueness of Maxwell's equation solution the rate of the boundary field values variations is proved completely informative with respect to the inner structural changes rate. In the paper the variations in measured field values at fixed boundary points are currently evaluated. On the basis of a statistical criterion is proposed to be established essential inner structural deformations or the presence of casual inclusions in previously homogenous field.

This approach is verified by an example referring to the 200MW turbine-generator. Typical failure is here due to the broken teeth parts in the stator core end packages [1].

R. D. Stancheva is with the Department of Theoretical Electrical Engineering, Technical University of Sofia, 8, Kl. Ohridski Blvd., 1000 Sofia, Bulgaria (corresponding author to provide phone: +359 2 965 3389; fax: +359 2 68 32 15; e-mail: rds@tu-sofia.bg).

I. I. Iatcheva, is with the Department of Theoretical Electrical Engineering, Technical University of Sofia, 8, Kl. Ohridski Blvd., 1000 Sofia, Bulgaria, (e-mail: iiach@tu-sofia.bg).

The present work is supported by the National Science Fund of Bulgarian Ministry of Education and Science, Project VU-EEC – 307/07.

While the radial magnetic flux in the core of the machine remains approximately constant at a constant terminal voltage axial flux density at the surfaces of clamping flange or the stator end packages strongly depends on the load current and the power factor. Accordingly to the nature of the diurnal load graphics the working modes are changed. The most dangerous are the regimes at the leading power factor [2]-[4]. The temperature calculations in the stator core end regions show that there are local temperatures over permissible ones at some regimes at the leading power factor. This effect leads to additional thermo-mechanical stresses with grate magnitude and as a consequence the clamping thumbs fatigue and some remaining deformations results. Distances between the thumbs and the stator core end packages gradually arise as well as those ones between the stator core end lamellae in the region of the teeth. Their vibrations grow up under the influence of the electromagnetic field variations. Some elementary lamellae are possible to be tearing away. As a result the winding breakdowns and the breakdowns to the earth are possible. So the temperature control in the end region is obliged. The describing problems are very serious and impose investigations to be carried out in two directions: the temperature distribution in the end region at the presence of broken part in the teeth and the sequels of it to be discussed at first, the possibilities for forecast the disruptions at the stator core inner structure is the second.

The dangerous situations in the stator core end are too expensive to be reproduced in nature. Because of this a numerical example is simulated at fault in the teeth zone. Electromagnetic and the resulting temperature field are calculated at these circumstances. On the basis of the appreciated changes in temperature distribution the conclusions with respect to the stator core state are made.

The identification problem is formulated taking into account currently observed temperature values on the stator core boundary. On the basis of a statistical criterion [5] the methodology includes recommendations for stator core end structural changes prediction. The application example is referring to 200MW turbine-generator.

II. IDENTIFICATION PROCEDURE

If the quantity a_{nc}^k is at boundary point k field value determined by numerical procedure (FEM) it could be considered as casual variable because of the round off and discretization errors. In accordance with the nature of these errors the variable has normal distribution. The relevant value a_{ne}^k determined experimentally at the same point as it is known is also normally distributed casual variable. Their deviation Δ found at point k by the relation $\Delta^k = abs(a_{nc}^k - a_{ne}^k)$ has than the same distribution. The unbiased variance estimator of the random quantity Δ

characterizes deviation as casual variable for all N boundary observed points. It is then defined by the term

$$s_{\Delta}^2 = \frac{\sum_{k=1}^N (\Delta^k - \bar{\Delta})^2}{N-1} \quad (1)$$

Here by

$$\bar{\Delta} = \frac{\sum_{k=1}^N \Delta^k}{N} \quad (2)$$

the mean of deviations at number N control points on investigated boundary is denoted. As a result of the current control at these points the value s_{Δ}^2 is periodically determined. When the set of new measured results is obtained the quantity T is found

$$T = \frac{s_{\Delta}^2}{s_{\Delta}^2} \quad (3)$$

It presents by the ratio between currently calculated variance s_{Δ}^2 and the initial one s_{Δ}^2 . The variance s_{Δ}^2 is primarily determined when there is not any accident in studied field. Implementing new step of current control the relevant value of T is found. The solution is obtained taking into consideration well known F statistical criterion. The comparison between just now calculated ratio T and the standard tabulated one F [2] pointed which of the hypotheses is correct. The commensurable of T with F means that the obtained currently measured boundary field values are determined with errors which have only occasional character. As bigger than the tabulated value F (α) the new calculated ratio T is as errors included v_1, v_2 in last obtained set of measured values are more significant. In this case the conclusion has been made that in investigated region some perceptible structural disturbance has been appeared. The value of the quantity F (α) v_1, v_2

depends on the level of significance α and the degrees of freedom v_1 and v_2 determining two compared variances. Since they are calculated on the basis of equal number N of casual memberships treatment in aggregate the degrees of freedom for their statistical assessments are equal, respectively $N-1$ and $N-1$. In ordinary investigations usually the level of significance α is accepted equal to 5%. Thus the accepted hypothesis is expected to be right with probability of 95%.

III. COUPLED FIELD MODEL

A. Electromagnetic field

An axial section of 200MW (TBB-200-2A) turbo-generator end region is shown in Fig.1.

The following assumptions have been made.

- The field is quasi-three-dimensional and three spatial components of the currents in the windings are taken into account.

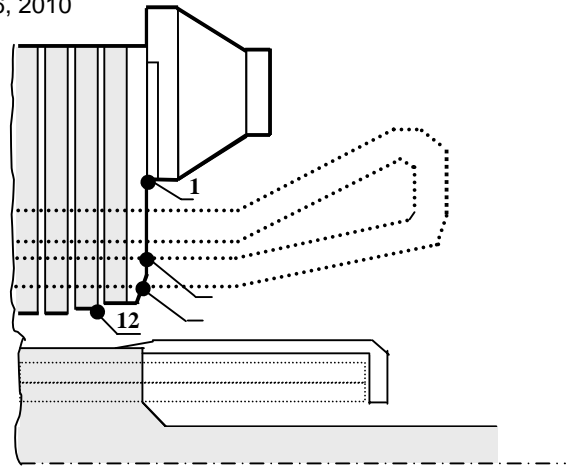

Fig. 1 Axial section of generator end region with control points

- The field is solved under steady-state mode as quasi-stationary.
- The separate parts of the stator and rotor end windings are represented as strips of finite dimensions with space-periodic currents defined by the actual winding currents.
- Only the effect of the first harmonic along the tangential coordinate is considered.
- Anisotropy in the teeth zone, eddy currents in the conductive media and the generator's operating mode (load angle and power factor) are also accounted for.
- The problem is considered linear.

The corresponding electromagnetic field equations for the steady state behaviour of the generator under sinusoidal input are given as

$$\text{rot}(\hat{\nu} \text{rot } \dot{\mathbf{A}}) = \hat{\sigma} \dot{\mathbf{E}} + \dot{\mathbf{J}}_e \quad (4)$$

$$\dot{\mathbf{E}} = -j\omega \dot{\mathbf{A}} - \text{grad } \dot{V} \quad (5)$$

In (4) tensors $\hat{\nu}$ and $\hat{\sigma}$ present the specific magnetic resistivity and the electric conductivity respectively. Their forms are due to the anisotropy of the medium. The quantities are noted as follows: $\dot{\mathbf{A}}$ is the magnetic vector potential, $\dot{\mathbf{E}}$ -the vector of electric intensity, $\dot{\mathbf{J}}_e$ -the exciting current density in the coils cross sections and \dot{V} -the scalar electric potential. In accordance with the assumptions that all electric and magnetic quantities vary only in sinusoidal manner vector and scalar variables in equations (4) and (5) are in complex form. The peculiarity of ordinary electrical machine is that axes of anisotropy and the co-ordinate axes of the device are coinciding. As a result the tensors $\hat{\nu}$ and $\hat{\sigma}$ are represented as diagonal matrices and the suitable gauge condition is valid [6,7]:

$$(\nu_r + \nu_\varphi + \nu_z) \text{div } \dot{\mathbf{A}} + (\sigma_r + \sigma_\varphi + \sigma_z) \dot{V} = 0 \quad (6)$$

Clearly in case of isotropy (6) is reduced to the well known gauge condition. The scalar electric potential \dot{V} and the magnetic vector-potential $\dot{\mathbf{A}}$ are determined by solving the system of equations (4), (5) and (6).

B. Temperature field

The eddy current losses of the conducting parts in the end zone of the machine are calculated and the distributed losses are applied as heat sources for the solution of the thermal problem. The temperature field is analysed as axisymmetrical. The following equation describes it

$$\text{div}(\lambda \text{ grad } T) + Q = 0. \tag{7}$$

The quantity T denotes temperature, λ -the thermal conductivity and Q -the density of the heat sources. It depends on the eddy current's density $\dot{\mathbf{J}}$ determined by equation

$$Q = 0.5\sigma^{-1} \dot{\mathbf{J}} \cdot \dot{\mathbf{J}}. \tag{8}$$

On the basis of the describing models formulation electromagnetic and temperature field are calculated by FEM and their distribution is found. The comparison between calculated and measured temperature results at two control points for twenty regimes show good agreement [8] by error not exciding 12%.

IV. SIMULATION OF BROKEN PART AT STATOR CORE END TEETH ZONE

Suppose that a part of the stator core tooth is broken. If the tooth height is h_z imagine that the m part of height is mh_z with $0 \leq m \leq 1$. The broken part depth is k -th part of the investigated end zone length l . The teeth region is considered anisotropic.

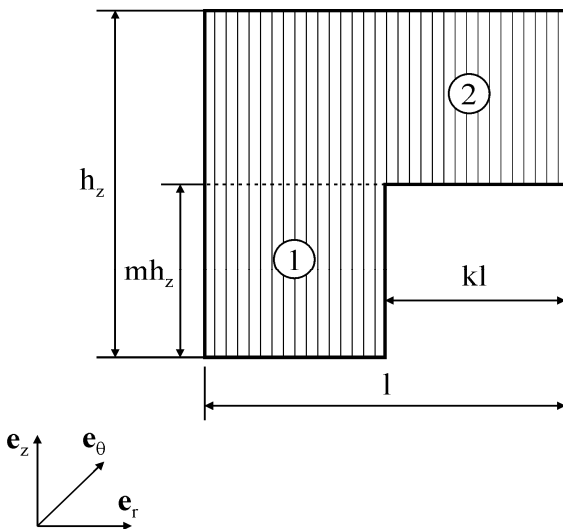

Fig. 2 Broken part of stator core teeth zone

in the region 1 equivalent relative magnetic permeability is calculated applying following expressions:

$$\mu_{r1} = \frac{b_k + b_z [(\mu_r - 1)(1 - k)k_f + 1]}{b_k + b_z}; \tag{9}$$

$$\mu_{\theta 1} = \frac{b_k + b_z}{b_k + \frac{b_z}{(\mu_r - 1)(1 - k)k_f + 1}}; \tag{10}$$

$$\mu_{z1} = \frac{b_k + \frac{b_z \mu_r}{(1 - \mu_r)(1 - k)k_f + \mu_r}}{b_k + b_z}. \tag{11}$$

Here the quantities b_k and b_z are the tooth and the slot widths, respectively; k_f is the coefficient of the stator core filling and μ_r is relative magnetic permeability of the material. The terms with respect to μ_r, μ_{θ} and μ_z in the region 2 are the same as (5), (6) and (7), but taking into account that $k = 0$. The theoretical results show that broken part mh_z of the height h_z does not participate in the expressions. For the investigated generator $b_k \approx b_z, k_f = 0.9$ and $\mu_r = 500$. If the depth of the broken part is referred to $k = 0.3$ the numerical results are: $\mu_{r1} = 158.190$; $\mu_{\theta 1} = 1.994$ and $\mu_{z1} = 1.850$. For normal state without any fault the calculated values are: $\mu_r = 225.550$, $\mu_{\theta} = 1.996$ and $\mu_z = 5.410$. The reduction of the values are: $\Delta_r \% = 29.8\%$; $\Delta_{\theta} \% = 0.7\%$ and $\Delta_z \% = 65.8\%$.

A. Temperature field distribution

The temperature distribution at rated mode is studied in the presence and without broken part at stator core end. The temperature map is presented in Fig.3.

The temperature field distribution at rated mode in the presence of broken part at stator core end teeth zone is shown in Fig.3a. The temperature distribution in Fig.3b is referring to the case without any disruptions in stator core inner structure.

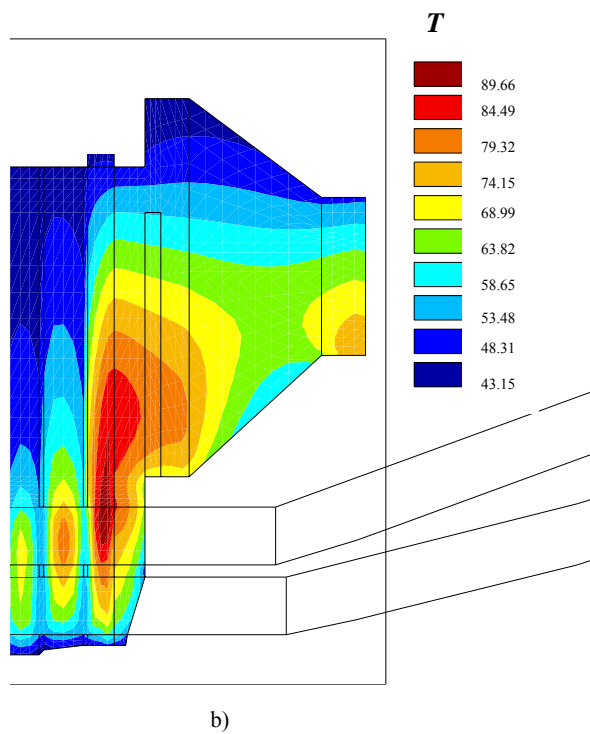
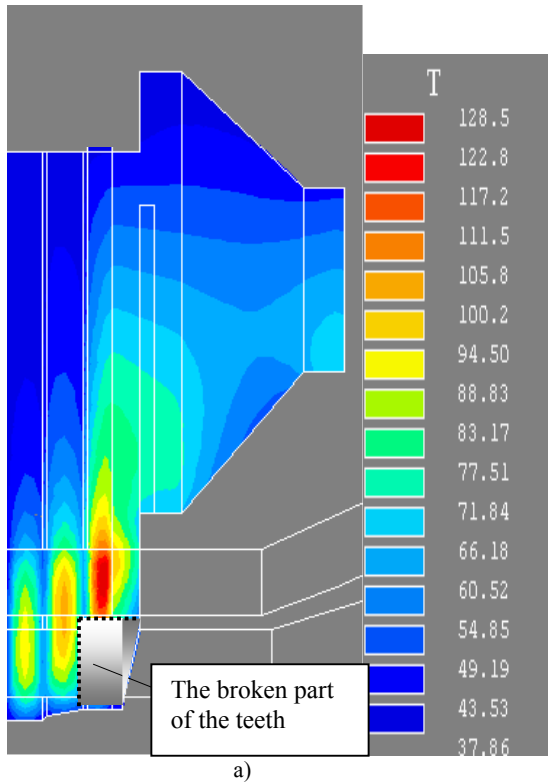

Fig. 3 Temperature field distribution at the presence a) and without broken tooth b) in stator core end

The comparison between the results shows that so described damage leads to the following changes in the temperature field map:

- Considerable redistribution of the field;
- The highest temperature level increases more than 30 percents. Its absolute value reaches 120°C. This is considerably more than permissible stator core temperature of 105°C;
- The temperatures at the second and the third packages increase at the same rate as in the first package;
- The most temperature loaded region is sharply-outlined. Its position in the stator core end zone remains approximately the same situated at first core package. But its location descends near to the broken part.
- The flange temperatures are not changed.

As a result of 30 percent temperature increasing the thermo-mechanical loads and vibrations enhancing are also expected. Lamellae insulation disturbance is in short time possible and the temperature and the vibration arising are the sequels. The stator core end zone damage is impending nearly in the future.

These machines and their reappearing take a lot of money. So it is very important to predict the describing situation in its beginning. The identification of the broken tooth part is proved possible in its come into being.

B. Identification problem solution

In essence the proposed method [5] of identification problem solution consists of the following. On the stator core boundary the temperature is currently watched at N accessible control points. It is preferable to measure temperatures instead of boundary inductions because of the fact that the induction values are considerably influenced by ferromagnetic surroundings. Let note the calculated temperature values at i -th control point by θ_c , the measured one without any fault in the stator core inner structure by $\hat{\theta}_m$ and the temperature value at the presence of a broken tooth by θ_m . The calculated and measured results are only discrete values and they are both determined with some statistical errors. For example applying numerical procedure (usually FEM) the temperature θ_c is determined as a random variable. The similar variables are affected by casual factors: the round-off error and the error of investigation region discretization. The nature of these errors shows that this random variable is normal distributed. The measured quantities $\hat{\theta}_m$ and θ_m are also normal distributed random variables because these are the characteristics of the casual factors influencing on them. Consequently the absolute value of the difference $\Delta\theta^i$ between the couple θ_c and θ_m determined at i -th point of the boundary is also normal distributed random variable

$$\Delta\theta^i = abs(\theta_c^i(x, y, z) - \theta_m^i(x, y, z)) . \quad (12)$$

The mean of the deviations at all investigated control points on the boundary is calculated by the expression

$$\overline{\Delta\theta} = \frac{\sum_{i=1}^N \Delta\theta^i}{N} \quad (13)$$

The unbiased variance estimator $s_{\Delta\theta}^2$ of the random variable $\Delta\theta$ is then defined by the term

$$s_{\Delta\theta}^2 = \frac{\sum_{i=1}^N (\Delta\theta^i - \overline{\Delta\theta})^2}{N - 1} \quad (14)$$

In the case of numerous observation points N the estimator $s_{\Delta\theta}^2$ is also characterized by standard distribution. The sum of the deviation squares of N independent random variables each normal distributed gives the result with chi-squared distribution χ_N^2 . Consequently the unbiased variance estimator $s_{\Delta\theta}^2$ of the random variable $\Delta\theta$ possesses the same distribution. When the set of new measured results is obtained during the time the ratio T_c between the currently calculated variance $s_{\Delta\theta}^2$ and the initial one $s_{\Delta\theta}^2$ (in the beginning of the testing control without any accidents) is evaluated

$$T_c = \frac{s_{\Delta\theta}^2}{s_{\Delta\theta}^2} \quad (15)$$

By this ratio two hypotheses are tested: the null hypothesis H_0 that the two compared variances are commensurable against the opposite hypothesis H_1 that $s_{\Delta\theta}^2 > s_{\Delta\theta}^2$. The comparison between the calculated T_c ratio and the standard tabulated one T_t pointed which one of the hypotheses is correct. If inequality

$$T_c > T_t \quad (12)$$

is realized it means that the hypothesis H_1 is right. Then the H_0 hypothesis is rejected. This means that the last obtained set of measuring values includes significant errors. In other words these errors haven't occasional character and it could be due only to the essential external influence. The right conclusion is that some structural disturbance in the inner structure of the stator core end zone has been appeared.

When the inner structure of the stator core end is broken the temperature values on the boundary ought to be sensitively changed. And taking into account the described methodology it is completely realistic detection of stator core end teeth zone break up.

V. METHOD REALIZATION

A. Numerical example

Consider 12 control points situated in a following way: the first one at the bottom of the tooth and all of the others to the

12-th is posed along the height of the tooth at equal distances to the bottom of the flange (Fig.1). The calculated θ_c , the measured temperatures without any fault $\hat{\theta}_m$ and the temperature values at the presence of a broken tooth θ_m are shown in the Tabl.1.

TABLE I
CALCULATED AND "EXPERIMENTAL" TEMPERATURE
RESULTS AT THE BOUNDARY

Point	$\hat{\theta}_c, ^\circ\text{C}$	$\hat{\theta}_m, ^\circ\text{C}$	$\theta_m, ^\circ\text{C}$
1	44.7	43.9	46.3
2	50.4	49.2	52.4
3	53.4	50.1	54.8
4	53.8	50.8	55.2
5	51.7	49.2	53.8
6	47.1	45.1	51.1
7	55.1	55.6	64.2
8	57.9	58.8	69.6
9	60.9	62.2	73.7
10	63.2	65.0	74.4
11	62.2	64.3	70.0
12	66.9	69.6	71.5

Because it is carried out only a numerical experiment as a simulation of the real situation the "measured" temperatures without any fault $\hat{\theta}_m$ are simulated as random generated values having normal distribution on the basis of the calculated ones θ_c . This acceptance takes into account the casual character of the errors of calculations and measurement and their probability distribution. These results are obtained considering that the generator has been worked at normal operating conditions. Therein the variable $\hat{\theta}_m$ is examined as initially measured set of temperature values. The temperature results θ_m are also calculated ones but at the presence of a broken tooth. Now the equivalent relative magnetic permeability along the coordinate axes μ_r, μ_θ and μ_z are calculated by the use of the expressions (5), (6), (7). The FEM calculations of the fields are made considering so presented anisotropy (2).

B. Statistical analysis

In accordance with the method described above the algorithm is implemented as follows:

- The mean (9) of deviations

$$\hat{\Delta\theta}^i = \text{abs}(\theta_c^i(x, y, z) - \hat{\theta}_m^i(x, y, z))$$

between calculated and initially measured results at all control points on the boundary is $\overline{\hat{\Delta\theta}} = 2.0$;

- The unbiased variance (10) of initially measured set of the values $\hat{\theta}_m$ referring to the state of electromagnetic device without any defects is $s_{\Delta\theta}^2 = 0.89$;
- The mean (9) of deviations

$$\hat{\Delta}\theta^i = \text{abs}(\theta_c^i(x, y, z) - \theta_m^i(x, y, z))$$

between the calculated and the “experimental” temperatures at the presence of the broken tooth part is $\overline{\Delta\theta} = 6.05$ and the unbiased variance respectively is $s_{\Delta\theta}^2 = 23.30$.

- On the basis of the obtaining results the ratio $T_c = 26.2$ is determined.
- Tabulated value of $T_t = F_{\nu_1, \nu_2}(\alpha) = 2.83$ criterion is found [9] characterized by $\nu_1 = \nu_2 = 11$ degrees of freedom and $\alpha = 0.05$ level of significance.

C. Results evaluation

The comparison $T_c \gg T_t$ proves that the set of the “experimental” temperature values θ_m includes a significant errors. These errors have not casual character. The inequality between T_c and T_t quantities is possible to be due only to the broken inner structure of the stator core end package.

VI. CONCLUSION

A part of stator core end teeth zone is simulated broken. The 30 percent temperature increasing at the region of the teeth in the stator core end packages is observed. This effect should be explains thermo-mechanical loads and vibrations enhancing in this zone.

The results of the new method realization are evaluated. The method is referring to the prediction of instantaneously came into being faults in the inner stator core end structure of the AC electrical machines.

A numerical example is regarded. In working mode instantaneously arising fault in the stator core end package is simulated. On the basis of a proposed statistical criterion the problem is specified.

REFERENCES

- [1] H. Karmakersi, "An experimental study of electromagnetic field distribution in large machines", *Int. conf. on the evolution and modern aspects of synchronous machines*, Zurich, Switzerland, Aug. 1991, pp. 522-524.
- [2] Silva, V., G. Meunier and A. Foggia, "A 3D finite-element computation of eddy currents and losses in the stator end laminations of large synchronous machines", *IEEE Trans. Magn.*, vol. 32, No. 3, 1996, pp.1569-1572.
- [3] Mecrow, B., G. Jack and C. Cross, "Electromagnetic design of turbo-generator stator end regions", *IEE Proceedings*, Part C, vol. 136, No. 6, 1989, pp.146-149.
- [4] Schastlivyi, G., G. Fedorenko and V. Vigovskyi, "Turbo and hydro generators under variable regimes", Kiev, *Naukova dumka*, in Russian, 1985.
- [5] Stancheva, R., "Statistical analysis application for the solution of some inverse problems in electrical devices", *5th International Conference on Applied Electromagnetics PES 2001*, Nish, Yugoslavia, 2001, pp.143-146.
- [6] Stancheva, R. and I. Iatcheva, "Numerical determination of operating chart of large turbine generator", *Int. Conf. on Electr. Machines ICEM'2002*, Book of Abstr., Full text on CD, Brugge-Belgium, 2002, pp. 329.
- [7] Stancheva, R. and I. Iatcheva, "Investigation of the electromagnetic field in the turbine-generator end region considering the anisotropy". *Electrical Engineering and Electronic*, 1-2, Bulgaria, 1995, pp.6-11.
- [8] Stancheva, R. and I. Iatcheva, "Turbogenerator stator core faults diagnosis on load", *International Agean conference on electrical machines and Power electronics*, ACEMP 2004, Istanbul, Turkey, 2004, pp. 30-35.
- [9] Smirnov, N., I. Dunin-Barkovski. *Course of Probability and Mathematical Statistics*, Science, M., in Russian, 1969.