

Transimpedance Amplifier for Integrated 3D Ultrasound Biomicroscope Applications

Xiwei Huang, Hyouk-Kyu Cha, Dongning Zhao, Bin Guo, Minkyu Je, Hao Yu

Abstract— This paper presents the design and implementation of a fully integrated transimpedance amplifier (TIA) as the analog front-end receiver for Capacitive Micromachined Ultrasound Transducers (CMUTs) for ultrasound biomicroscope imaging application. The amplifier is designed to amplify the received signals from 17.5MHz to 52.5MHz with a center frequency of 35MHz. The TIA was fabricated in GF 0.18 μ m 1P6M 30V high voltage process. The measurement results show that the designed amplifier can reach a transimpedance gain of 61.08dB Ω and operating frequency from 17.5MHz to 100MHz with 1VP-P output voltage under 6V power supply.

Keywords—3D ultrasound biomicroscope, analog front-end, transimpedance amplifier, CMUT

I. INTRODUCTION

ULTRASOUND imaging has often been used in medical applications as a diagnostic tool [1] mainly due to its much less-harmful characteristic to the human body in comparison to other method such as X-rays. In addition, the lower cost and real-time imaging capability are some of the key advantages of ultrasound imaging compared with magnetic resonance imaging (MRI) and computed tomography (CT) [2].

Ultrasound biomicroscope (UBM) is a type of ultrasound imaging system that makes a more detailed image than regular ultrasound system. UBM systems are applicable for diagnostic imaging of corneal diseases, glaucoma, cysts and tumors [3]. For UBM, the three-dimensional (3D) UBM provides important clinical benefits beyond traditional two-dimensional (2D) UBM. In contrast to 2D ultrasound imaging system which send acoustic waves straight down and reflect back, 3D ultrasound imaging sends them at different angles through an 2D transducer array and allows one to see width, height and depth of images. It also greatly increases the utility of analyzing images after the examination, potentially leading to less difficult and less expensive examinations.

In recent years, the Capacitive Micromachined Ultrasound Transducer (CMUT) [4] technology has become a popular alternative to the conventional piezoelectric transducer after the development of silicon micromachining techniques. CMUTs offer various advantages over piezoelectric transducers, including easier integration with readout electronic circuits, wider bandwidth which results in better axial resolution, increased flexibility in array design, and operating over a wider temperature range, offering high-frequency/high-resolution capability to replace bulky, discrete solutions [5].

Xiwei Huang and Hao Yu are with the School of Electrical and Electronic Engineering, Nanyang Technological University, Singapore, 639798 (e-mail: huan0234@ntu.edu.sg, haoyu@ntu.edu.sg).

Xiwei Huang, Dongning Zhao, Bin Guo and Minkyu Je are with Institute of Microelectronics, A*STAR, Singapore. (e-mail: jemk@ime.a-star.edu.sg)

Hyouk-Kyu Cha was with IME and is now with Department of Electrical Engineering and Information Technology, Seoul National University of Science and Technology, Seoul, Korea.

As the advances in semiconductor technology continue to allow for scaled, power-efficient, and low-cost integrated circuits to integrate together with CMUTs, more research and development have been conducted on portable integrated biomedical ultrasound imaging systems [6-8].

However, there are usually two major issues associated with 3D ultrasound biomicroscope imaging: increased transducer element count and the reduced signal strength of individual array element due to limitations in the physical dimensions. A solution to interfacing electronics with 2D transducer arrays is to combine the CMUT array with an integrated circuit (IC). Implementing more of the system electronics with an IC can reduce the cost of 3D UBM imaging systems and build the real portable fully-integrated 3D UBM system.

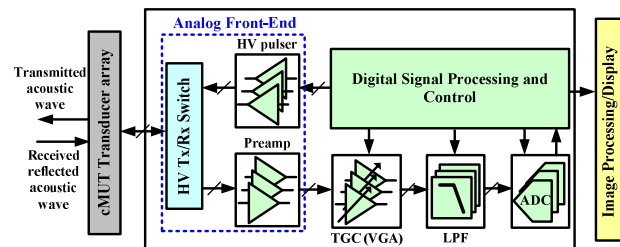

Fig. 1 System diagram of ultrasound imaging system

In the 3D UBM system, each of the front-end interface circuit designed for ultrasound system consists of a high voltage pulser circuit, a protection switch, and a readout amplifier as the system functional block diagram shown in Fig. 1. The advantage of IC pulser and preamplifier is that they can be provided to every element in the array without expensive external electronics or long cables. We employ the monolithic CMUT-on-CMOS flip-chip bonding with Through-Silicon-Via (TSV) to integrate the CMUT transducer with the high voltage pulser and analog receiving amplifier. This can greatly increase the receiving sensitivity. Besides the preamplifier at the front-end, the receiving path also includes Time-Gain Compensation (TGC), Low-Pass Filter (LPF) and Analog-to-Digital Converter (ADC). The received signals need further signal processing to obtain the final 3D ultrasound images. Multiple channels and transducers are required for high-performance 3D ultrasound imaging systems.

This paper presents a transimpedance amplifier design for fully-integrated 3D UBM application with demonstrated measurement results. A design methodology is also introduced that integrates the preamplifier with the high voltage pulser and the CMUT. The remaining part of this paper is organized as follows. In section II, the CMUT is introduced. In section III, we present the transimpedance amplifier design. The simulation and measurement results are presented in section IV. Finally, section V concludes the whole paper.

II. CMUT

Capacitive Micromachined Ultrasound Transducer (CMUT) is basically a transducer that converts ultrasound acoustic waves into electrical signals and vice versa. The energy transduction is due to capacitance change. As shown in Fig. 2, the CMUT in our work consists of a suspended membrane built on a conductive silicon substrate. The CMUT is operated using electrostatic forces: an applied DC bias voltage causes the membrane to deflect toward the substrate, while an AC pulse imposed on the device causes the membrane to vibrate, emitting acoustic power to the surrounding medium. When used for reception, the incident acoustic field causes a change in the device capacitance, which will be detected by the receiving sensing circuits. The readout signals need further digital signal processing to create medical images. The front-end interface circuit designed for 3D UBM contains a 2D array of circuits, each consisting of a driver circuit, a protection circuit, a receiving amplifier, and a TSV with bonding pad for vertical flip-chip bonding of the transducer array and analog front-end IC. Our design parameters for CMUT are shown in Table I.

TABLE I
DESIGN PARAMETERS FOR CMUT

Parameter	Values	
CMUT array (elements)	16×16	
CMUT cells per element	20×20	
CMUT cell geometrical profile	Width	28μm
	Depth	28μm
	Thickness	3μm
	Gap size	0.1μm
CMUT excitation voltage (V _{P-P})	20V	
Bandwidth	17.5-52.5MHz	
Capacitance per element (deflated)	44pF	

III. CIRCUIT DESIGN AND IMPLEMENTATION

A. Design specifications

As the preamplifier is used to readout the received signals from CMUT, the design specs for preamplifier are calculated from the CMUT design parameters. The full details for the CMUT design are not included in this paper, and we just give out the design specs for preamplifier as in Table II. Note that the output load is from the input of the on-board TGC at the next stage of our analog front-end.

TABLE II
DESIGN SPECS FOR PREAMPLIFIER

Parameters	Specs.
Supply Voltage	6V
Gain	61.18dbΩ
3dB Bandwidth	52.5MHz
Output Voltage	1V _{P-P}
Output Load	3.2pF/310KΩ

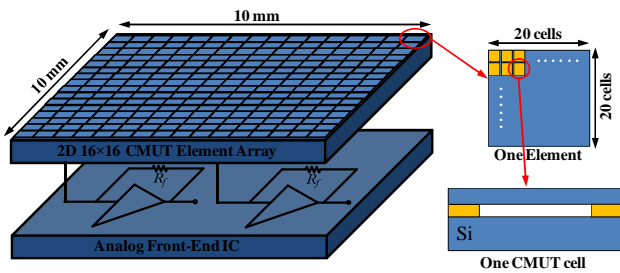

Fig. 2 Diagram of flip-chip bonded 2D CMUT array with analog front-end IC and the cross-section view of one CMUT device

As the CMUT is the input stage for the preamplifier, the equivalent model of the CMUT is important for preamplifier design. We directly give out the equivalent model as in Fig. 3. Basically it is an AC current source in parallel with the deflated capacitance of the CMUT. This model is derived from the CMUT design, the deriving process is not in the scope of this paper.

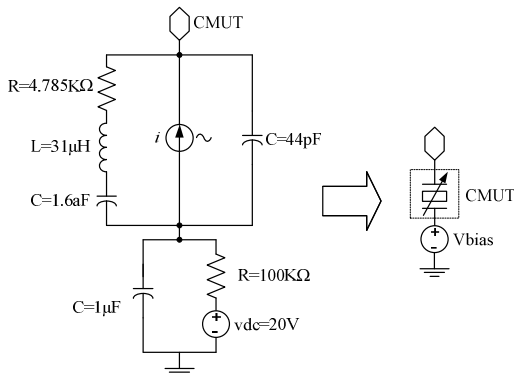

Fig. 3 Equivalent simulation model for CMUT

B. Transimpedance Amplifier Design

According to the design specs from the CMUT in Table 2, we choose a resistive feedback transimpedance amplifier (TIA) as the preamplifier at the analog receiving front-end. The resistive feedback TIA is a popular topology as the front-end receiver for low-noise detection [9].

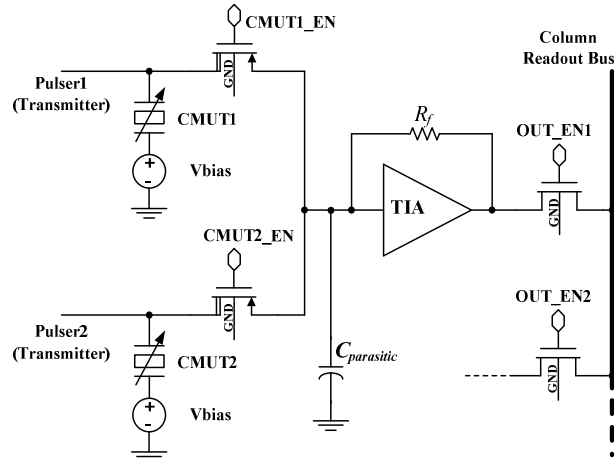

Fig. 4 Analog front-end schematic

The analog front-end circuit is shown in Fig. 4. Each preamplifier is shared by two CMUTs and two pulsers.

And the output for all the preamplifier in one column is connected together to a column readout bus. This configuration is due to the big area of the pulser and preamplifier layout. As one CMUT element size is $600\mu\text{m}\times 600\mu\text{m}$, now two pulsers and one preamplifier are in an area of $600\mu\text{m}\times 1200\mu\text{m}$. Note that there are also two bonding pad areas for two TSVs to interconnect the analog electronics with the CMUT.

The schematic for the TIA is shown in Fig. 5. The transimpedance amplifier is composed of a single-ended amplifier and a feedback resistor R_f . The single-ended amplifier consists of a common-source amplifier followed by an N-type source follower. Differential input circuits are not used as the unused differential input usually will add extra input referred noise. The transimpedance amplifier acts as a current-to-voltage converter, which has a low input impedance, making it well suited for high-impedance sources. The input stage of the preamplifier is the CMUT. During the design simulation, we use the equivalent circuit in Fig. 3 to represent the CMUT. Moreover, we also add an additional parasitic capacitance of 1pF between the TIA input and ground due to the flip-chip bonding for the CMUT element and the analog front-end.

The gain of the transimpedance amplifier is set by the feedback resistance R_f . That's the reason we choose the resistance to be $1.15\text{K}\Omega$, which when translated to gain is $61.18\text{dB}\Omega$. The bandwidth of the preamplifier is dominated by the capacitance in parallel with the feedback resistor, which is approximated by

$$\omega_{TIA} = \frac{1}{R_f \cdot C_f} \quad (1)$$

where C_f is the parasitic capacitance in parallel with the feedback resistor. The primary noise sources of the transimpedance amplifier are the noise of the common source amplifier and the feedback transistor.

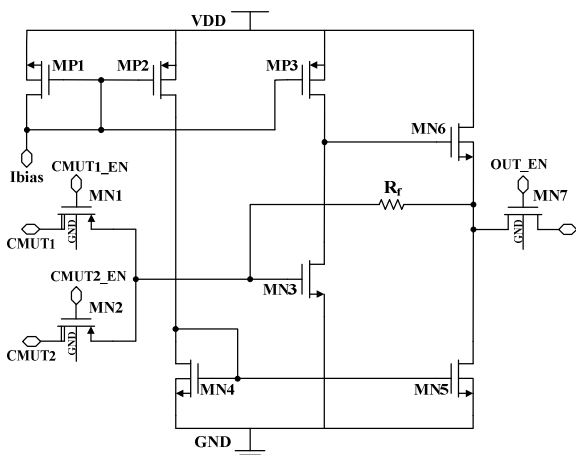

Fig. 5 Resistive feedback TIA schematic

To choose between the two CMUT inputs, we have two digital controlled switches MN1 and MN2 at the input of the common source transistor. Different from all the other 6V transistors used, these two transistors are asymmetrical nmos_30p0 which can sustain 30V high voltage input at the drain terminal. The driver circuit generates high-voltage pulses (30v) on the node where the CMUT is connected. The receiving preamplifier was designed for low-voltage operation. Thus the two switches are used as the protection transistors to prevent high-voltage pulses from damaging the input transistors of the readout amplifier. The output enable switch is normal nmos_6p0 transistor.

As our testing for the TIA is based on PCB, we designed a unity gain analog buffer on chip at the output of the TIA. The simulated bandwidth can cover 280MHz, much larger than the required TIA bandwidth so that it won't affect the TIA output testing. After the analog buffer, the output stage is the on-board TGC, which is a $310\text{K}\Omega$ resistor in parallel with one 3.2pF capacitor. The whole load circuit schematic is shown in Fig. 6. Besides the TGC input load, the on-chip parasitics, chip-to-board parasitics and on-board parasitics are also considered.

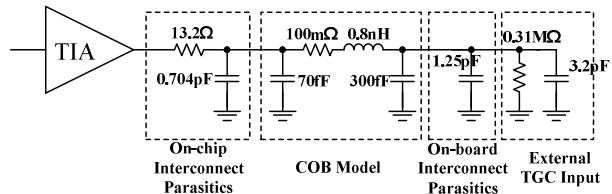

Fig. 6 TIA whole load circuits

IV. MEASUREMENT RESULTS

The functional simulation of the TIA design was verified using Cadence Spectre simulator. For the circuit fabrication, we use the Global Foundry $0.18\mu\text{m}$ 1P6M 30V high voltage process technology for this design. This technology provides high-voltage-enabled MOSFETs operational up to 30V as well as low-voltage standard 5V and 6V MOSFETs. Note that as we are fabricating the preamplifier with the high voltage pulser, deep N-well needs to be used for the preamplifier transistors to reduce the noise effect from the pulser. The TIA test chip photo is shown in Fig. 7.

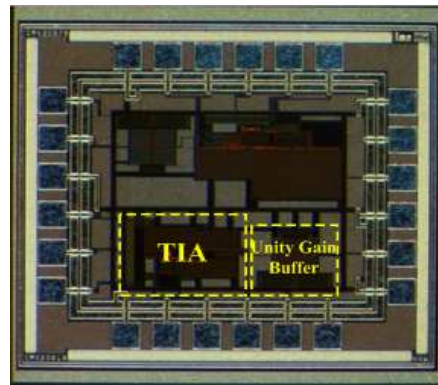

Fig. 7 TIA testing chip photo

During the testing, we give a power supply of 6V, and 80 μ A input bias current. As our design specs require a transimpedance gain of 61.18dB Ω , we put a 560 Ω resistor at the input of the TIA and measure the current through this resistor. This current is also the input current of the TIA. Then we measure the voltage at the output node of TIA. By dividing the measured output voltage with the input current, we obtained the transimpedance gain-bandwidth plot as shown in Fig. 8. It clearly shows that the operational frequency of the designed TIA can cover the required CMUT frequency bandwidth with 61dB Ω transimpedance gain. The 1V_{P-P} output measurement result is shown in Fig. 9. This 1V_{P-P} result is obtained with a 100mV, 35MHz voltage source input. And the measured total current for the TIA is 13mA.

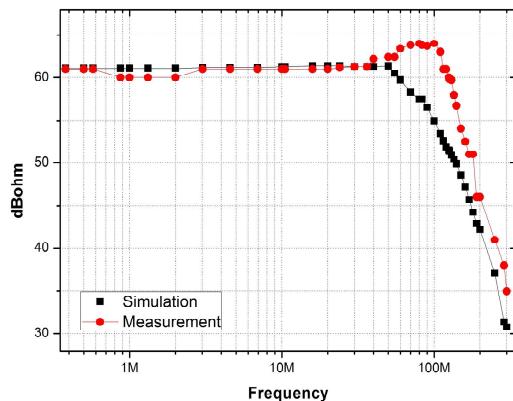

Fig. 8 TIA gain and bandwidth measurement results

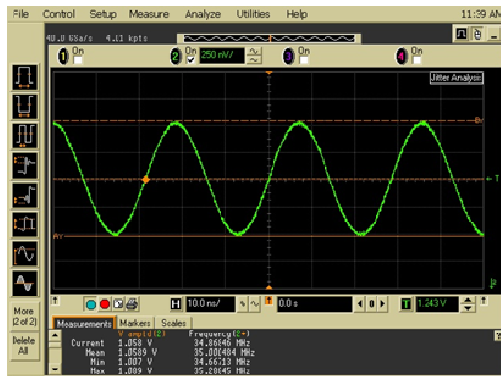

Fig. 9 TIA 1V_{P-P} measurement result

V. CONCLUSION

We present the design and implementation of a fully integrated front-end transimpedance amplifier with the flip-chip bonded 2D CMUT array for 3D ultrasound biomicroscope imaging application. The TIA is fabricated with the Global Foundry 0.18 μ m 1P6M 30V HV process. The measurement results of the front-end TIA validate its ability to meet the specifications from CMUT for 3D UBM application. Our future work is to build and test the whole UBM system with CMUTs and pulsers all integrated together.

REFERENCES

- [1] P. Levesque and M. Sawan, "Novel low-power ultrasound digital preprocessing architecture for wireless display," *IEEE Trans. on Ultrasonics, Ferroelectrics, and Frequency Control*, vol. 57, no.3, pp. 757-767, 2010.
- [2] I. Wygant et al., "An integrated circuit with transmit beamforming flip-chip bonded to a 2-D CMUT array for 3-D ultrasound imaging," *IEEE Trans. on Ultrasonics, Ferroelectrics, and Frequency Control*, vol. 56, no.10, pp. 2145-2156, 2009.
- [3] R. H. Silverman, "High-resolution ultrasound imaging of the eye – a review," *Clin Experiment Ophthalmol*, vol. 37, no.1, pp. 54–67, 2009.
- [4] I. Ladabaum, X. C. Jin, H. T. Soh, A. Atalar, and B. T. Khuri-Yakub, "Surface micromachined capacitive ultrasonic transducers," *IEEE Trans. on Ultrasonics, Ferroelectrics, and Frequency Control*, vol. 45, no. 3, pp. 678–690, May 1998.
- [5] D. Zhao, M. T. Tan, H.-K. Cha, J. Qu, M. Yan, H. Yu, A. Basu, and M.-K. Je, "High-voltage pulser for ultrasound medical imaging applications." 13th Int. Symp. on Integrated Circuits (ISIC), pp. 408-411, 2011.
- [6] M. Fuller et al., "Experimental system prototype of a portable, low-cost, C-scan ultrasound imaging device," *IEEE Trans. on Biomedical Engineering*, vol. 55, no.2, pp. 519-530, Feb. 2008.
- [7] I. Wygant et al., "Integration of 2D CMUT arrays with front-end electronics for volumetric ultrasound imaging," *IEEE Trans. Ultrasonics, Ferroelectrics, and Frequency Control*, vol. 55, no.2 pp. 327-342, Feb. 2008.
- [8] K. Insoo, et al., "CMOS Ultrasound Transceiver Chip for High-Resolution Ultrasonic Imaging Systems," *IEEE Trans. on Biomedical Circuits and Systems*, vol. 3, no. 5, pp. 293-303, 2009.
- [9] G. Gurun, et al., "Front-end CMOS electronics for monolithic integration with CMUT arrays: Circuit design and initial experimental results," *IEEE Ultrasonics Symposium (IUS)*, pp. 390-393, 2008.