

# CFD Simulation of Dense Gas Extraction through Polymeric Membranes

Azam Marjani\*, Saeed Shirazian

**Abstract**—In this study is presented a general methodology to predict the performance of a continuous near-critical fluid extraction process to remove compounds from aqueous solutions using hollow fiber membrane contactors. A comprehensive 2D mathematical model was developed to study Porocritical extraction process. The system studied in this work is a membrane based extractor of ethanol and acetone from aqueous solutions using near-critical CO<sub>2</sub>. Predictions of extraction percentages obtained by simulations have been compared to the experimental values reported by Bothun et al. [5]. Simulations of extraction percentage of ethanol and acetone show an average difference of 9.3% and 6.5% with the experimental data, respectively. More accurate predictions of the extraction of acetone could be explained by a better estimation of the transport properties in the aqueous phase that controls the extraction of this solute.

**Keywords**—Solvent extraction, Membrane, Mass transfer, Dense gas, Modeling

## I. INTRODUCTION

WHEN a compound is subjected to temperatures and pressures higher than the critical values, it is defined as a “supercritical fluid (SCF)”. Under these conditions the SCF shows very interesting transport and surface properties as well as a high solubilizing capacity due to the transition between gas and liquid phases and its high density. The most popular compound used as SCF is carbon dioxide (CO<sub>2</sub>) because it is inexpensive, non-toxic and inert. Moreover, CO<sub>2</sub> has a relatively low critical point (7.38MPa, 304.15 K), which involves many interesting applications as alternative solvent, reaction medium or adjuvant to reduce the viscosity of the medium. In spite of the progress reached in materials technology and membrane processes, few operations coupling SCF and membrane technologies have been proposed in the literature [1-4]. PoroCrit process or Porocritical extraction is a commercial SFE which uses a hollow fiber membrane contactor (HFMC) [3]. In this process a macroporous membrane allows contact between two phases. An aqueous liquid solution is circulated on one side and on the other side the extraction solvent is a near-critical or SCF. When the membrane used is hydrophobic, the aqueous solution does not penetrate into the membrane pores. A meniscus is formed at the mouth of the pores stabilizing a dense gas–liquid interface. The chemical potential gradient that generates a mass transfer through the membrane is a concentration gradient between the

two phases. In this process the membrane does not play a determinant role as a selective barrier, and the selectivity is determined mainly by the vapor–liquid equilibrium between both phases. Fig. 1 shows schematically the principle of this process. In a typical configuration, hollow fiber macroporous polypropylene membranes with a mean pore diameter of 0.2 μm are used [4]. This process has several advantages compared to conventional contactor devices used in solvent and SCF extraction, like conventional contacting columns which disperse one fluid phase in another. High throughput capacity without column flooding or emulsion formation, independence from solvent and feed density differences, and design modularity can be mentioned among its most important advantages. The reduced complexity of the process and its comparative low cost allow a wider industrial use of CO<sub>2</sub> as a non-toxic and environmentally benign extraction solvent. Furthermore, the most interesting characteristic of this process is the use of an HFMC. This module geometry is usually 100 times more efficient on a volumetric basis (m<sup>2</sup>/m<sup>3</sup>) than a conventional contactor [4-8].

## II. MODEL DEVELOPMENTS

The mass transfer model was validated by comparing results of extraction percentages of ethanol and acetone from aqueous solutions obtained from simulations with experimental data reported by Bothun et al. [5]. In the experiments, an HFMC has been used with near-critical and SC CO<sub>2</sub> as extraction solvent. Fig. 2 shows a diagram of the experimental device. The system consists of a single hollow fiber housed in stainless steel tubing. The liquid feed (aqueous solution) circulates inside the fiber and the extraction fluid (near-critical and SC CO<sub>2</sub>) circulates in countercurrent flow outside the fiber. The solute is recovered by expansion through a valve from the extracting stream. The raffinate is collected for analysis. The raffinate receiver also works as an equalizing vessel connected with the extraction gas current in order to maintain the same pressure inside and outside the fiber and therefore ensure the stabilization of the interface within the membrane porosity. In this way, an equality condition for pressures and temperatures has been considered in calculations. Operating conditions, structural parameters of the membrane, and configuration characteristics considered in simulations are reported in Table 1.

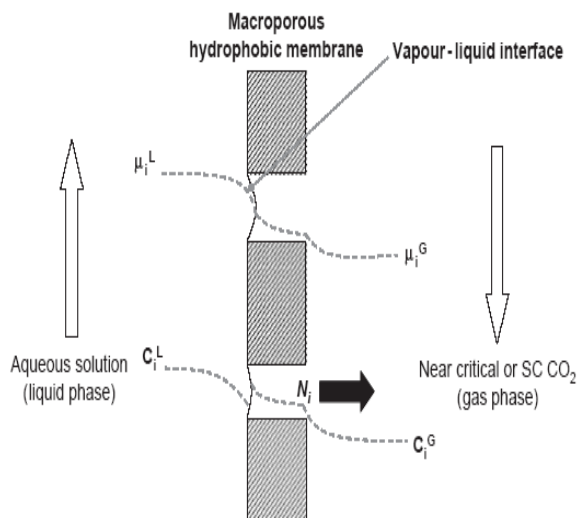

Fig. 1. Principle of mass transfer in porous extraction [8].

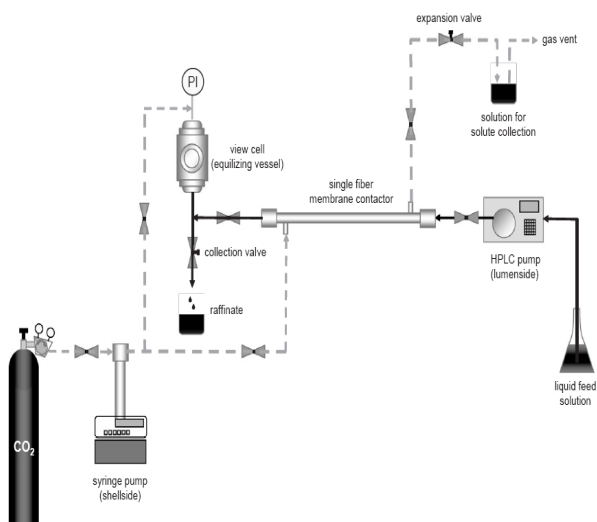

Fig. 2. Experimental device used in experiments [5, 8].

The continuity equations for three subdomains of contactor were obtained and solved to predict the concentrations of liquid phase along the contactor. The model is developed for a hollow fiber, as shown in Fig. 3, through which the liquid flows with a fully developed laminar parabolic velocity profile. The fiber is surrounded by a laminar gas flow in an opposite direction. Therefore, the membrane contactor consists of three sections: tube side, membrane, and shell side. The steady state two-dimensional material balances are carried out for all three sections. The gas mixture is fed to the shell side (at  $z = L$ ), while the liquid phase is passed through the tube side (at  $z = 0$ ).

TABLE I  
OPERATIONAL CONDITIONS CONSIDERED IN THE SIMULATIONS OF  
POROCRITICAL EXTRACTION [5]

Operating conditions used in the experiments

Pressure (MPa)	6.9
Temperature (K)	298
Liquid feed concentration (%w/w)	10
Solutes (aqueous solutions)	Ethanol & acetone
Liquid feed (aqueous solution), $F$ ( $\text{ml min}^{-1}$ )	0.1–1.0
Molar flow ratio, S/F	3
Structural parameters of the hollow fiber membrane contactor	
Material (characteristic)	Polypropylene (hydrophobic)
Number of fibers, $n$	1
Fiber length, $L$ (m)	1.067
Porosity, $\epsilon$ (%)	75
Mean pore diameter, ( $\mu\text{m}$ )	0.4
Fiber ID, (mm)	0.6
Fiber OD, (mm)	1.02
Shell ID, (mm)	1.52
Shell OD, (mm)	3.18

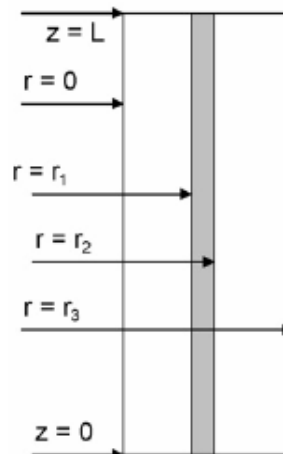

Fig. 3. Model domain

The used assumptions were: (1) steady state and isothermal conditions; (2) fully developed parabolic liquid velocity profile in the hollow fiber; (3) the Henry's law is applicable for gas-liquid interface; (4) The aqueous feed phase and the dense extraction gas are considered immiscible; (5) The transition limit between laminar and turbulent regimes on the shell side was considered between 2100 and 4000 for Reynolds number. We now apply the continuity equations for three subdomains of contactor.

### III. SHELL SIDE

The continuity equation for each species in a reactive system can be expressed as [6]:

$$\frac{\partial C_i}{\partial t} = -(\nabla \cdot C_i V) - (\nabla \cdot J_i) + R_i \quad (1)$$

where  $C_i, J_i, R_i, V$  and  $t$  are the concentration, diffusive flux, reaction rate of species  $i$ , velocity and time, respectively. Either Fick's law of diffusion or Maxwell–Stefan theory can be used for the determination of diffusive fluxes of species  $i$ . The continuity equation for steady state for solute in the shell side of contactor for cylindrical coordinate is obtained using Fick's law of diffusion for the estimation of the diffusive flux:

$$D_{i-shell} \left[ \frac{\partial^2 C_{i-shell}}{\partial r^2} + \frac{1}{r} \frac{\partial C_{i-shell}}{\partial r} + \frac{\partial^2 C_{i-shell}}{\partial z^2} \right] = V_{z-shell} \frac{\partial C_{i-shell}}{\partial z} \quad (2)$$

We use Happel's model [7] to characterize the out fibers velocity profile. The laminar parabolic velocity profile in the outside fibers is:

$$V_{z-shell} = 2u \left[ 1 - \left( \frac{r_2}{r_3} \right)^2 \right] \times \frac{(r/r_3)^2 - (r_2/r_3)^2 + 2 \ln(r_2/r)}{3 + (r_2/r_3)^4 - 4(r_2/r_3)^2 + 4 \ln(r_2/r_3)} \quad (3)$$

where  $u, r_3, r_2$  represent the average velocity, radius of free surface (Fig. 3) and fiber outer radius, respectively.

Boundary conditions for shell side are given as:

$$\text{at } z = L, \quad C_{i-shell} = C_{i-inlet} = 0 \quad (4)$$

$$\text{at } r = r_3, \quad \frac{\partial C_{i-shell}}{\partial r} = 0 \text{ (insulation)} \quad (5)$$

$$\text{at } r = r_2, \quad C_{i-shell} = C_{i-membrane} \quad (6)$$

#### IV. MEMBRANE

The steady-state continuity equation for the transport of solute inside the membrane, which is considered to be due to diffusion alone, may be written as:

$$D_{i-membrane} \left[ \frac{\partial^2 C_{i-membrane}}{\partial r^2} + \frac{1}{r} \frac{\partial C_{i-membrane}}{\partial r} + \frac{\partial^2 C_{i-membrane}}{\partial z^2} \right] = 0 \quad (7)$$

Boundary conditions are given as:

$$\text{at } r = r_2, \quad C_{i-membrane} = C_{i-shell} \quad (8)$$

$$\text{at } r = r_1, \quad C_{i-membrane} = C_{i-tube} \times m \quad (9)$$

where  $m$  is the partition coefficient of solute in the SCF.

#### V. TUBE SIDE

The steady-state continuity equation for the transport of solute in the tube side may be written as:

$$D_{i-tube} \left[ \frac{\partial^2 C_{i-tube}}{\partial r^2} + \frac{1}{r} \frac{\partial C_{i-tube}}{\partial r} + \frac{\partial^2 C_{i-tube}}{\partial z^2} \right] = V_{z-tube} \frac{\partial C_{i-tube}}{\partial z} \quad (10)$$

The velocity distribution in the tube is assumed to follow Newtonian laminar flow [6]:

$$V_{z-tube} = 2u \left[ 1 - \left( \frac{r}{r_1} \right)^2 \right] \quad (11)$$

where  $u$  is average velocity in the tube side.

Boundary conditions:

$$\text{at } z = 0, \quad C_{i-tube} = C_{i-inlet} \quad (12)$$

$$\text{at } r = r_1, \quad C_{i-tube} = C_{i-membrane} / m \quad (13)$$

$$\text{at } r = 0, \quad \frac{\partial C_{i-tube}}{\partial r} = 0 \text{ (symmetry)} \quad (14)$$

The dimensionless model equations related to tube, membrane and shell side with the appropriate boundary conditions were solved using COMSOL software, which uses finite element method (FEM) for numerical solutions of differential equations. The finite element analysis is combined with adaptive meshing and error control using a variety of numerical solvers such as DASP. This solver is an implicit time-stepping scheme, which is well suited for solving stiff and non-stiff non-linear boundary value problems.

## VI. RESULTS AND DISCUSSION

### A. Validation of the mass transfer model

The extraction percentage of solute can be calculated from the equation below:

$$\begin{aligned} \% \text{ removal} &= \frac{(v \times C)_{inlet} - (v \times C)_{outlet}}{(v \times C)_{inlet}} \\ &= 100 \left( 1 - \frac{C_{outlet}}{C_{inlet}} \right) \end{aligned} \quad (15)$$

where  $v$  and  $C$  are the volumetric flow rate and concentration, respectively.  $C_{outlet}$  is calculated by integrating the local concentration at outlet of tube side ( $z=L$ ):

$$C_{outlet} = \frac{\iint C(r) dA}{\iint_{Z=L} dA} \quad (16)$$

The change in volumetric flow rate is assumed to be negligible and thus extraction percentage can be approximated by eq. (15).

Calculations of the extraction percentage (defined by Eq. (15)) using the simulation developed in this study were

compared with the experimental data reported by Bothun et al. [5]. Figures 4 and 5 show the calculated and experimental extraction percentage as a function of the liquid feed flow (F). Comparing the extraction percentage estimated for ethanol and acetone, better accuracy is found in the predictions for acetone separation. This could be accounted for considering two aspects: better prediction of transport properties (viscosity, diffusion coefficient) in the hydrodynamic characterization, and correct estimation of the vapor-liquid equilibrium in the ternary acetone-CO<sub>2</sub>-water system. For both systems studied greater accuracy of the model was obtained at lower values of the liquid feed flow (F), and for dense gas extraction flow (S), since the S/F ratio remains constant (S/F = 3) for most of the experimental measurements [8].

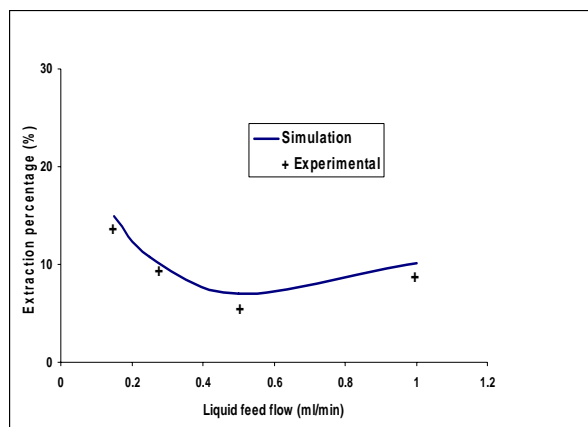

Fig. 4. Extraction percentage values of ethanol from aqueous solutions (10%w/w) obtained from experiments (Bothun et al., 2003) and simulation (this work). Molar flow ratio is S/F = 3, P = 6.9MPa, T = 298K.

The predicting capacity of the model is improved considering a laminar circulation regime in the shell side. From figures 4 and 5 we can observe the most important discrepancy between experimental and calculated extraction percentages when the liquid flow increases. This discrepancy should be attributed to the fact that the fluid is probably not in laminar regime, but in transition. This decrease in the predictive capacity of the model explained by changes in the hydrodynamic conditions in the shell side can explain the evolution of the extraction percentage of ethanol as a function of the flow seen in figure 4. On the other hand, simulations carried out modifying the mass transfer mechanism in the membrane porosity are presented in figures 4 and 5. Simulations of extraction percentage of ethanol and acetone show an average difference of 9.3% and 6.5% with the experimental data, respectively.

#### B. Hydrophobicity/hydrophilicity of the membrane

The effect of the membrane hydrophobicity on the mass transfer of the Porocritical process was studied using the simulation model developed in this work.

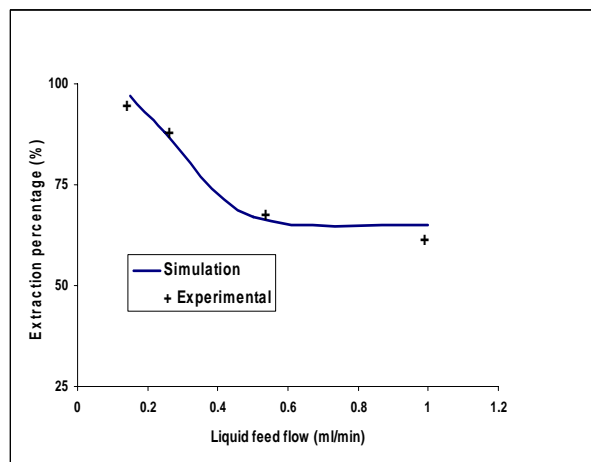

Fig. 5. Extraction percentage values of acetone from aqueous solutions (10%w/w) obtained from experiments (Bothun et al., 2003) and simulation (this work). Molar flow ratio is S/F = 3, P = 6.9MPa, T = 298K.

A hydrophobic membrane allows stabilizing the gas-liquid interface at the pore entrance and the aqueous solution cannot wet the porosity. In this case, membrane porosity is filled with extraction gas. For a hydrophilic membrane, the porosity is filled with the aqueous phase and the mass transfer in the pores would be described by molecular diffusion of ethanol or acetone in liquid medium. Figs. 6 presents calculated extraction percentages of ethanol. These values were obtained by simulation considering a completely hydrophobic or hydrophilic membrane when the aqueous solution is circulated in the lumen side. Results obtained by simulation show that the hydrophobicity of the membrane increases extraction percentage of solute.

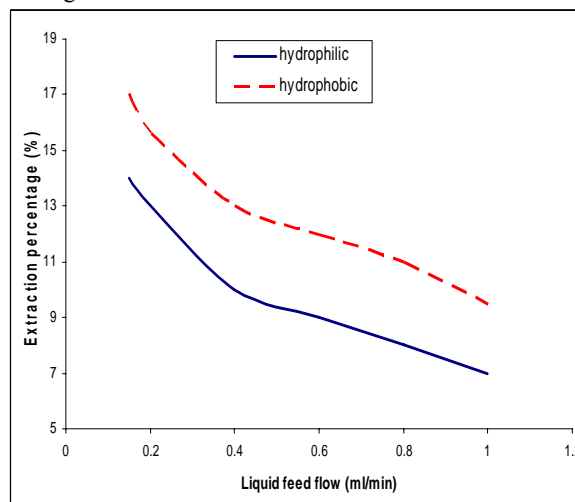

Fig. 6. Estimation of the extraction percentages of ethanol from an aqueous solution (10%w/w) as a function of the liquid feed (F) for a hydrophobic and a hydrophilic membrane when the molar flow ratio is S/F = 4, P = 6.9MPa, T = 298K.

#### VII. CONCLUSIONS

A 2D mathematical model was developed to study the Porocritical extraction in hollow fiber membrane contactors.

The model predicts the steady state liquid feed concentration in the contactor by solving the conservation equations. The model was developed for non-wetting conditions, taking into consideration axial and radial diffusion in the tube, membrane and shell sides of the contactor. The model was then validated using experimental data reported by Bothun et al. [5] for extraction of ethanol and acetone from aqueous solutions. The simulations results indicated that the extraction percentage of liquid feed increased with decreasing liquid velocity in the tube side.

## REFERENCES

- [1] M. Sims, Porocritical fluid extraction from liquids using near-critical fluids. *Membrane Technology* 97 (1998), 11–12.
- [2] G. Afrane, E.H. Chimowitz, Experimental investigation of a new supercritical fluid-inorganic membrane separation process. *Journal of Membrane Science* 116 (1996), 293–299.
- [3] M. Sims, E. McGovern, J.R. Robinson, Porocritical fluid extraction application: continuous pilot extraction of natural products from liquids with near critical fluids. *Proceeding of the Fifth Meeting on Supercritical Fluids, Materials and Natural Processing, Nice, France, March (1998)*.
- [4] M. Budich, G. Brunner, Supercritical fluid extraction of ethanol from aqueous solutions. *Journal of Supercritical Fluids* 25 (2003), 45–55.
- [5] G. Bothun, B. Knutson, H. Strobel, S. Nokes, E. Brignole, S. Diaz, Compressed solvents for the extraction of fermentation products within a hollow fiber membrane contactor. *Journal of Supercritical Fluids* 25 (2003), 119–134.
- [6] R.B. Bird, W.E. Stewart, E.N. Lightfoot, *Transport Phenomena*, JohnWiley & Sons, 1960.
- [7] J. Happel, Viscous flow relative to arrays of cylinders, *AIChE J.* 5 (1959) 174–177.
- [8] Estay, H.; Bocquet, S.; Romeroa, J.; Sanchez, J.; Rios, G. M.; Valenzuela, F. Modeling and simulation of mass transfer in near-critical extraction using a hollow fiber membrane contactor. *Chem. Eng. Sci.* 2007, 62, 5794–5808.