

Universal Current-Mode OTA-C KHN Biquad

Dalibor Bielek, Viera Biolková, and Zdeněk Kolka

Abstract—A universal current-mode biquad is described which represents an economical variant of well-known KHN (Kerwin, Huelsman, Newcomb) voltage-mode filter. The circuit consists of two multiple-output OTAs and of two grounded capacitors. Utilizing simple splitter of the input current and a pair of jumpers, all the basic 2nd-order transfer functions can be implemented. The principle is verified by Spice simulation on the level of a CMOS structure of OTAs.

Keywords—Biquad, current mode, OTA.

I. INTRODUCTION

THE gm-C circuits represent a popular technique of integrated realization of frequency filters. The biquads for cascade synthesis are mostly based on the principle of two integrators in a feedback loop [1]. However, the voltage-mode version of these circuits leads to a relatively large number of active components [2] which can cause, among other things, the stability problems and high-frequency imperfections. The current mode with the utilization of multiple-output (MO) OTAs features more economical topologies. A biquad with three OTA amplifiers and two grounded capacitors from [3] offers the basic transfer functions of LP, BP, and BR types (low-pass, high-pass, and band-reject). The quality factor is adjustable via the transconductance of one OTA without disturbing the characteristic frequency f_0 . The universal biquad with a minimum number of components (2 OTAs and 2 grounded capacitors) is described by Chang in [4]. In general, this circuit has three current inputs. Their combining allows all the basic transfer functions. However, some combinations assume splitting the input current into more circuit nodes or its multiplying by two, which must be implemented by auxiliary circuitries. Two universal biquads are proposed by Bhaskar et al. in [5]. Each of them contains four OTAs and two grounded capacitors. Further analysis shows that the filter core is composed of two integrators in a feedback loop such as in [4], and that the remaining two OTAs form a current amplifier for prospective electronic control of the biquad gain. The circuit universality is raised up

by a possibility to leave out one OTA and to use the second one as a voltage to current converter. Then the biquad can operate in the trans-admittance mode.

A universal biquad is described below, whose synthesis starts from the flow graphs of conventional KHN (Kerwin, Huelsman, Newcomb) filter. The resulting structure of “two integrators in a feedback loop” is similar to those in [4]. However, in contrast to [4] and [5], the various types of transfer functions are not achieved by complicated combination of more input currents. Three independent current outputs of “LP”, “BP”, and “BR” types are available in the basic configuration. Utilizing two jumpers, the “BR” transfer function can be modified to the “HP” or “AP” types (high-pass or all-pass).

II. SYNTHESIS OF CURRENT-MODE OTA-C KHN BIQUAD

The flow graph, which corresponds to the classical structure of the KHN filter, is shown in Fig. 1. The facts that the circuit variables are not voltages but currents as well as that the G_m -C integrators will be used are also reflected in the graph.

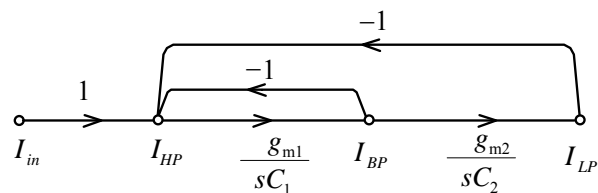

Fig. 1 Flow graph of current-mode KHN biquad

The following transfer functions result from this graph:

$$\frac{I_{HP}}{I_{in}} = \frac{s^2}{\Delta}, \quad \frac{I_{BP}}{I_{in}} = \frac{s\omega_0/Q}{\Delta}, \quad \frac{I_{LP}}{I_{in}} = \frac{\omega_0^2}{\Delta}, \quad (1)$$

where

$$\Delta = s^2 + s\frac{\omega_0}{Q} + \omega_0^2, \quad \omega_0 = \sqrt{\frac{g_{m1}g_{m2}}{C_1C_2}}, \quad Q = \sqrt{\frac{C_1g_{m2}}{C_2g_{m1}}}. \quad (2)$$

The circuit implementation, flowing from the graph, is in Fig. 2. Note that the current I_{HP} flows through the capacitor C_1 and thus its utilization as an output signal is problematic. The current outputs of OTA amplifiers provide only the high-impedance outputs I_{LP} and I_{BP} . The remaining transfer functions will be implemented via a proper interconnection of inputs and outputs on the basis of the following equations:

Manuscript received August 23, 2007. This work was supported in part by the Grant Agency of the Czech Republic under Grants Nos. 102/05/0771 and 102/05/0277, and by the research programmes of BUT MSM0021630503, MSM 0021630513, and UD Brno MO FVT0000403.

D. Bielek is with the Department of Microelectronics/EE of Brno University of Technology/Univ. of Defence, Brno, Czech Republic (phone: +420-973442487; fax: +420-973442987; e-mail: dalibor.bielek@unob.cz).

V. Biolková and Z. Kolka are with the Department of Radioelectronics, Brno University of Technology, Brno, Czech (e-mails: biolkova@feec.vutbr.cz and kolka@feec.vutbr.cz).

$$\frac{I_{HP}}{I_{in}} = \frac{s^2}{\Delta} = \frac{I_{in} - I_{LP} - I_{BP}}{I_{in}} \quad (3a)$$

$$\frac{I_{BR}}{I_{in}} = \frac{s^2 + \omega_0^2}{\Delta} = \frac{I_{in} - I_{BP}}{I_{in}} \quad (3b)$$

$$\frac{I_{AP}}{I_{in}} = \frac{s^2 - s\omega_0/Q + \omega_0^2}{\Delta} = \frac{I_{in} - 2I_{BP}}{I_{in}} \quad (3c)$$

Note that the “BR” output is obtained by subtracting the output current of the “BP” section from the input current. After subsequent subtraction of current I_{LP} / I_{BP} we get the „HP“/“AP” output. That is why the output I_X in Fig. 2 provides a signal which character depends on the state of dashed jumpers. Without any jumpers, this output is of the “BR” type.

The input current duplication can be accomplished e.g. by a simple current mirror or via a circuit with two OTAs according to [5]. The latter method also enables controlling the gain of entire filter or the trans-admittance operation.

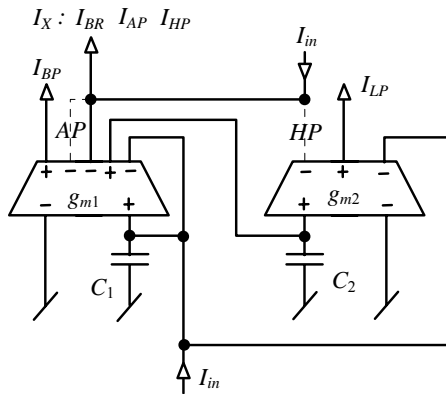

Fig. 2 Proposed current-mode universal biquad

III. SPICE SIMULATION

The filter functionality was verified via Spice simulation of its model. The OTA amplifiers were modeled as the CMOS structure in Fig. 3 [6] with 0.5µm MIETEC transistor parameters. The W/L ratios are in Table I. The transconductance g_m is varied within the range of 199µA/V to 635µA/V while changing the current I_{bias} from 20µA to 700µA. The supply voltage is ±2.5V.

The amplitude frequency responses in Fig. 4 were obtained for the following circuit parameters: $I_{bias}=700\mu A$, $C_1=40pF$, $C_2=5pF$. The theoretical values of the characteristic frequency and of the quality factor are $f_0 = 7.146MHz$, $Q=2.828$. The values, extracted from the simulation results, are in a good agreement: $f_0 = 7.122MHz$, $Q=2.814$. Exactly speaking, their reading from the frequency responses is rather problematic due to the below discussed modifications of filter performance by real properties of OTAs. The frequency f_0 was read as a coordinate when the phase response has passed the level of 90 degrees, and the quality factor from the 3dB bandwidth of “BP” section.

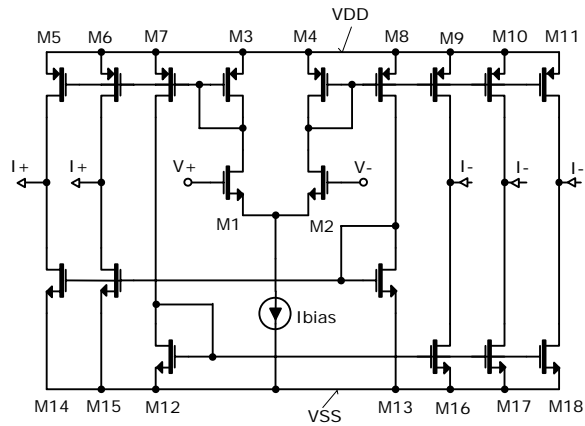

Fig. 3 CMOS structure of OTA amplifier. Adopted from [6] and modified for 5-output type

TABLE I
W/L TRANSISTOR RATIOS

Transistor	W [µm] / L [µm] ^a
M1 – M2	16 / 1
M3 – M11	6 / 1
M12 – M18	4 / 1

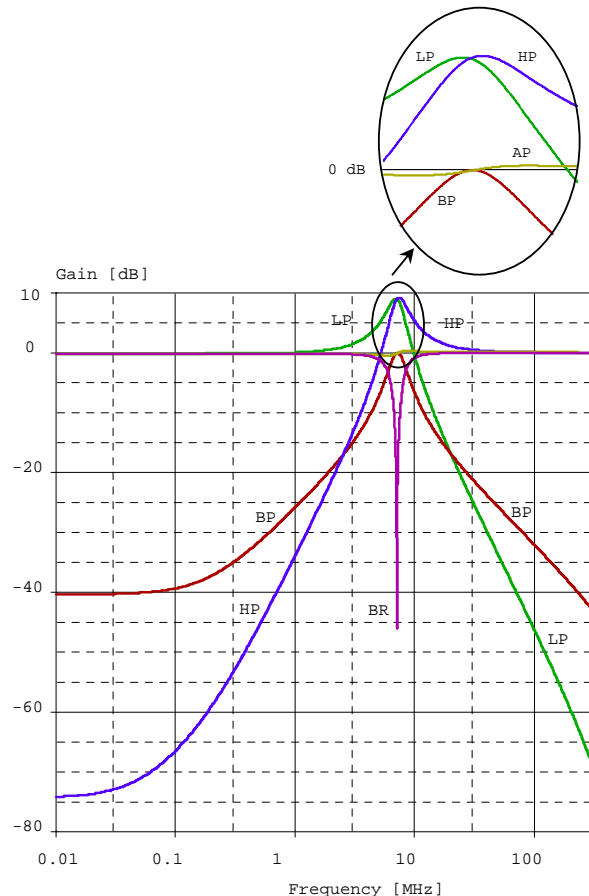

Fig. 4 Amplitude frequency responses of filter in Fig. 2 (Spice simulation)

The “BP” and “HP” frequency responses show finite parasitic attenuations at low frequencies. This phenomenon is common for such structures of OTA-C filters, as obvious e.g. from the atypical phase response of “HP” filter in [4]. The zoom around the frequency f_0 reveals a tiny ripple of the “AP” gain. As shown below, the cause consists in the finite output resistances of OTA amplifiers. Since the identical models of current-mirroring transistors are applied in Spice model of OTA amplifier in Fig. 3, the simulation results cannot describe another real effects caused by the current mismatch. That is why a brief error analysis will be also included.

IV. ANALYSIS OF REAL EFFECTS

A. Influence of OTA Output Resistances

Spice simulation of OTA model in Fig. 3 confirms the negligible input conductivity. On the other hand, it shows the output resistances which can affect the low-frequency gains. The output resistance R_{out} is 6.25MΩ for $I_{bias}=20\mu A$ (i.e. $g_m=199\mu A/V$) and only 150kΩ for $I_{bias}=700\mu A$ (i.e. $g_m=625\mu A/V$). The latter value was applied for the above simulation.

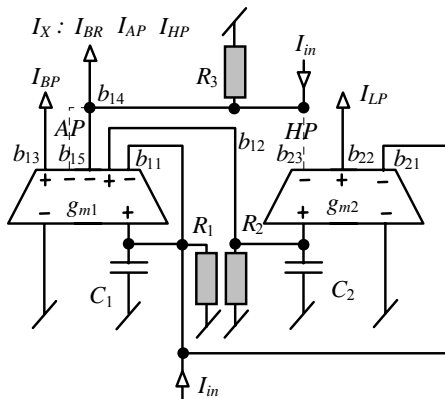

Fig. 5 The effect of parasitic resistances in biquad

The biquad schematics is recalled in Fig. 5 with included parasitic resistances R_1 , R_2 , and R_3 , which model an influence of OTA output resistances, particularly:

$$R_1 = R_{out}/2, R_2 = R_{out}, R_3 = R_{out} \text{ for } I_{BR}, \text{ and } R_{out}/2 \text{ for } I_{AP} \text{ and } I_{HP}.$$

In practice, the R_1 and R_3 resistances will be subsequently decreased due to the input resistance of the I_{in} source. However, this influence can be minimized through the design of input current splitter.

The negative influence of R_3 can be eliminated by connecting the current output I_X to low-impedance load. The following analysis is thus focused on the influence of R_1 and R_2 resistances to the „LP“ and „BP“ outputs, from which the remaining outputs are derived.

The analysis of circuit in Fig. 5 yields the following transfer functions:

$$\frac{I_{LP}}{I_{in}} = \frac{\omega_0^2}{\Delta'}, \frac{I_{BP}}{I_{in}} = \frac{s \frac{\omega_0}{Q} + \frac{\omega_0^2}{g_{m2}R_2}}{\Delta'}, \Delta' = s^2 + s \frac{\omega_0'}{Q'} + \omega_0'^2, \quad (4)$$

$$\omega_0' = \omega_0 \sqrt{r}, r = 1 + \frac{1}{g_{m2}R_2} + \frac{1}{g_{m1}R_1 g_{m2}R_2}, \quad (5a)$$

$$Q' = Q \frac{\sqrt{r}}{1 + \frac{Q^2}{g_{m2}R_2} + \frac{1}{g_{m1}R_1}} \quad (5b)$$

As obvious from the above results, the finite values of OTA output resistances cause the ω_0 and Q modifications as well as the parasitic zero in “BP” transfer function which dominantly degrades the low-frequency transfer. The measure of this influence is given by the product of transconductance and parasitic resistance. This product specifies the value of transfer zero and the error term r whereon ω_0 and Q modifications depend. This term also determines the measure of the fall of low-frequency gain of the “LP” section. For our case, its value is $r = 1.00535$. That is why only the influence of parasitic transfer zero is significant. A simple arrangement of the numerator of (4) enables an interpretation of this zero as a parasitic cutoff frequency

$$\omega_r = \frac{1}{R_2 C_2}. \quad (6)$$

Its value is 212kHz. This frequency is well evident on the “BP” frequency response in Fig. 4. The simulation shows a value of 191kHz.

The value of a parasitic low-pass gain of “BP” section can be derived from (4):

$$K_{BP}^0 = \frac{\omega_0^2}{\omega_0'^2 g_{m2}R_2} = \frac{1}{1 + g_{m2}R_2 + \frac{1}{g_{m1}R_1}} = \frac{1}{g_{m2}R_2 r}. \quad (7)$$

The numerical value -39.7dB is in a good accordance with the Spice simulation (-40.4dB).

The analysis of parasitic low-frequency gain of the “HP” section can be done accordingly with the result as follows:

$$K_{HP}^0 = \frac{1}{g_{m1}R_1 g_{m2}R_2 r}. \quad (8)$$

The value of -73.2dB is again consistent with the simulation result of -74.3dB.

The low-frequency “LP”, “BR”, and “AP” gains are here:

$$K_{LP}^0 = \frac{1}{r}, K_{BR}^0 = 1 - \frac{1}{g_{m2}R_2 r}, K_{AP}^0 = 1 - \frac{2}{g_{m2}R_2 r} \quad (9)$$

For “LP” and “BR” outputs, the deviations from the ideal values are negligible. For “AP” section, the corresponding ripple is -0.182dB which is in a good conformity with the

simulation (-0.171dB).

B. Influence of Current Matching Errors

The proper filter operation requires the equality of all output currents of multiple-output OTA. In other words, the current gains of all current mirrors should be one. These gains, labeled by the "b" symbol, are marked in Fig. 5 near each output of OTAs. The spread of gains b_{11} , b_{12} , and b_{21} around the ideal values of "1" will cause the ω_0 and Q modifications. The spread of gains b_{13} and b_{22} will affect the gains of "BP" and "LP" sections. The remaining gains affect the way of combining the current signals to the "HP", "BR", and "AP" outputs which impacts the transfer zeros of the corresponding transfer functions.

Considering the influence of parasitic current gains, the analysis of filter in Fig. 5 yields the modified values of ω_0 a Q :

$$\omega_0'' = \omega_0 \sqrt{b_{12}b_{21}}, \quad Q'' = Q \frac{\sqrt{b_{12}b_{21}}}{b_{11}}. \quad (8)$$

The low-frequency gain of the "LP" section and the maximum gain of the "BP" section will be changed as follows:

$$K_{LP}^0 = \frac{b_{22}}{b_{21}}, \quad K_{BP}^{\max} = \frac{b_{13}}{b_{21}}. \quad (9)$$

The sensitivities of the above quantities to the parasitic current gains are either 1/2 or ± 1 . Considering the maximum deviations of 1% of these gains around their nominal values 1, the worst-case deflection of ω_0 a Q would be of 1% and worst-case deflection of quantities (9) would be of 2%.

For the "HP" output, the parasitic low-frequency transfer appears whereas the high-frequency gain remains unitary. For "BR" and "AP" outputs, the low-and high-frequency gains remain unitary, but the resonant gains will be modified as follows:

$$K_{HP}^0 = 1 - \frac{b_{23}}{b_{21}}, \quad K_{BR}^{\text{rez}} = 1 - \frac{b_{14}}{b_{11}}, \quad K_{AP}^{\text{rez}} = 1 - \frac{b_{14} + b_{15}}{b_{11}}. \quad (10)$$

For 1% maximum deviations of current gains, the worst-case analysis leads to the resonant transfer of "AP" filter up to 0.35dB. The low-frequency attenuation of "HP" section is only 34dB. The identical value is true for the gain rejection of "AP" filter. This attenuation is increased to 54dB when decreasing the maximum deflections of current gains to 0.1%. When these attenuations are too low comparing them to the requested one and when the current matching cannot be improved, then the use of "HP" and "BR" outputs is not encouraged. This conclusion is true not only for the above biquad but also for all similar recently published current-mode biquads, which use the sensitive method of subtracting the current signals for the implementation of the remaining transfer functions [3-5].

V. CONCLUSION

The described biquad embodies advantageous features of Chang circuit [5]: It is simple because it consists of only two multiple-output OTAs and two grounded capacitors. The ω_0 and Q sensitivities are low. The electronic ω_0 a Q control does not affect the gains of individual filter sections. Furthermore, the specific advantage consists in the selection of the filter type by simple interconnecting concrete OTA outputs with the filter current output. The Spice simulations show a good conformity with the theoretical parameters of the filter. For low-frequency region, parasitic transfers to the "BP" and "HP" outputs appear. It is shown that this effect is caused by the finite value of the OTA output resistance. To eliminate this, the product of this resistance and the OTA transconductance should be sufficiently greater than 1. The ω_0 and Q sensitivities to the matching errors of current mirrors are also low. However, these errors generate the parasitic transfer zeros of "BR", "HP", and "AP" transfer functions which are assembled from the "LP" and "BP" transfer functions. It results in high sensitivities of the parasitic gains of "HP" and "BR" filters to the mirror mismatch. That is why when using the "HP" or "BR" outputs, it is necessary to ensure the best possible matching of the current gains b_{23} and b_{21} , or b_{14} and b_{11} . In the case of CMOS technology, the attainable matching error is of about 1%, causing too small low-frequency attenuations at "HP" and "BP" outputs. This error would be necessary to decrease by special compensation techniques [7]. This conclusion is also applied to all the recently published biquads [3], [4], [5] which operate on the principle of compounding the currents from OTA multiple outputs.

REFERENCES

- [1] E. Sánchez-Sinencio, E., R. L. Geiger, and H. Nevarez-Lozano, „Generation of Continuous-Time Two Integrator Loop OTA Filter Structures,“ *IEEE Trans. on CAS*, vol. 35, No. 8, 1988, pp. 936-946.
- [2] T. Deliyannis, Y. Sun, and J. K. Fidler, *Continuous time active filter design*. CRC Press, USA, 1999.
- [3] C.-M. Chang, B. M. Al-Hashimi, and J. N. Ross, „Unified Active Filter Biquad Structures,“ *IEE Proc.-Circuits Devices Syst.*, vol. 151, No. 4, August 2004, pp. 273-277.
- [4] C.-M. Chang, and S.-K. Pai, „Universal Current-Mode OTA-C Biquad with the Minimum Components,“ *IEEE Trans. on CAS*, vol. 47, No. 8, 2000, pp. 1235-1238.
- [5] D. R. Bhaskar, A. K. Singh, R. K. Sharma, and R. Senani, „New OTA-C Universal Current-Mode/Trans-Admittance Biquads,“ *IEICE Electronics Express*, vol. 2, No. 1, 2005, pp. 9-13.
- [6] A. Ü. Keskin, D. Biölek, E. Hancıoğlu, and V. Biölková, „Current-mode KHN filter employing Current Differencing Transconductance Amplifiers,“ *AEU - International Journal of Electronics and Communications*, vol. 60, Issue 6, 2006, pp. 443-446.
- [7] S. Byun, and J. Laskar, „Digitally tuned Gm-C filter with VDD/temperature-compensating DAC,“ *Electronics Letters*, Vol. 43, No. 5, 2007, pp. 35-36.