

A Multimedia Telemonitoring Network for Healthcare

Hariton N. Costin, Sorin Puscoci, Cristian Rotariu, Bogdan Dionisie, and Marinela C. Cimpoesu

Abstract—TELMES project aims to develop a securized multimedia system devoted to medical consultation teleservices. It will be finalized with a pilot system for a regional telecenters network that connects local telecenters, having as support multimedia platforms. This network will enable the implementation of complex medical teleservices (teleconsultations, telemonitoring, homecare, urgency medicine, etc.) for a broader range of patients and medical professionals, mainly for family doctors and those people living in rural or isolated regions. Thus, a multimedia, scalable network, based on modern IT&C paradigms, will result. It will gather two inter-connected regional telecenters, in Iași and Pitești, Romania, each of them also permitting local connections of hospitals, diagnostic and treatment centers, as well as local networks of family doctors, patients, even educational entities. As communications infrastructure, we aim to develop a combined fix-mobile-internet (broadband) links. Other possible communication environments will be GSM/GPRS/3G and radio waves. The electrocardiogram (ECG) acquisition, internet transmission and local analysis, using embedded technologies, was already successfully done for patients' telemonitoring.

Keywords—Healthcare, telemedicine, telemonitoring, ECG analysis.

I. INTRODUCTION

IN spite of decreased mortality, coronary artery disease still remains the leading cause of death almost all over the world. The existence of silent myocardial ischemia emphasizes the need for monitoring of the asymptotic patient. Extended patient monitoring during normal activity has become increasingly important as a standard preventive cardiologic procedure for detection of cardiac arrhythmias, transient ischemic episodes and silent myocardial ischemia. Existing "holter" devices mostly record "24-hour activity" and then perform off-line record analysis, so they are not real-time.

The task may also be achieved by *telemedicine* (enabling medical information-exchange as the support to distant-

decision-making) and *telemonitoring* (enabling simultaneous distant-monitoring of a patient and his vital functions), both having many advantages over traditional practice. A telemonitoring network (Fig. 1) devoted to medical teleservices, will enable the implementation of complex medical teleservices for a broader range of patients and medical professionals, mainly for family doctors and those people living in rural or isolated regions.

Doctors can receive information that has a longer time span than a patient's normal stay in a hospital and this information has great long-term effects on home health care, including reduced expenses for health care. Physicians also have more accessibility to experts, allowing the physician to obtain information on diseases and provide the best health care available. Moreover, patients can thus save time, money and comfort.

As for patient monitoring, we propose the development of a flexible environment based on an acquisition module and an embedded system for real-time biosignals processing and transmission through Internet, GPRS/3G (mobile telephony) or radio networks already existing in each Romanian county.

II. TELEMONITORING MODULE

A. General Structure

Our patient telemonitoring module is based on an ECG / biosignal acquisition module and an embedded system, for real-time signal processing and transmission through Internet (Fig. 2). It is built by using custom developed hardware, open-source and application software.

For instance, the monitoring device could be used either for acquisition of anomalous ECG sequences (e.g. with arrhythmic events, ST segment deviation,

This work was supported by a grant from the Romanian Ministry of Education and Research, within CEEEX program (www.mct-excelenta.ro), contract No. 604/645/21.10.2005.

H. N. Costin, C. Rotariu, and B. Dionisie are with the Faculty of Medical Bioengineering, Univ. of Medicine and Pharmacy, Iasi, Romania, 700098, str. Universitatii 16, (phone: +40-232-213573; fax: +40-232-211820; e-mail: hcostin@gmail.com).

S. Puscoci is with the National Institute of Telecommunications, 062203, B-dul Preciziei Nr.6, sector 6, Bucharest, Romania. (e-mail: sorp@quickweb.ro).

M. C. Cimpoesu is with the "Stefan cel Mare" National College, Suceava, Romania, (e-mail: monicacimpoesu@yahoo.com).

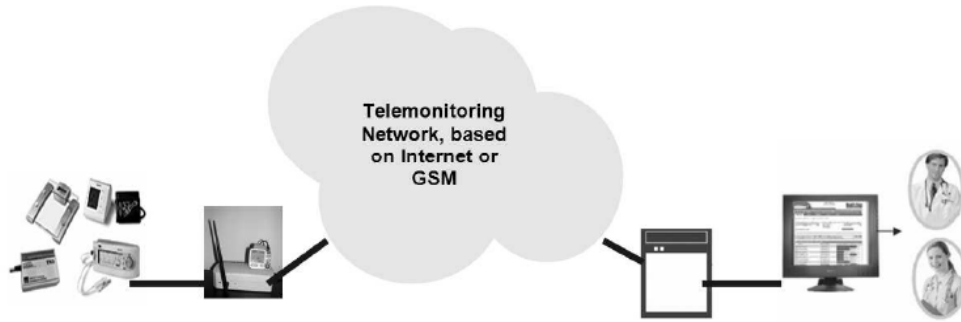

Medical devices Network interface Telemonitoring server Telemonitoring Center

Fig. 1 A medical telemonitoring network – general structure

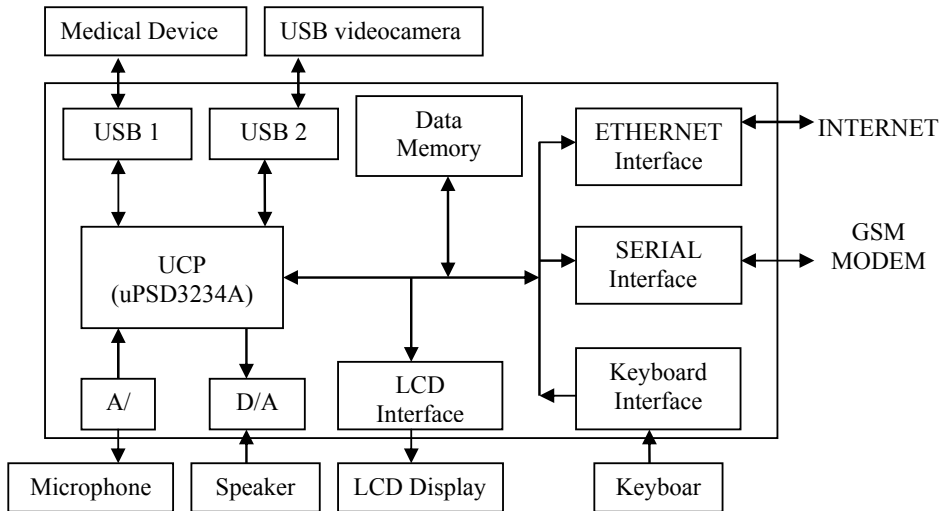

Fig. 2 The biosignal / ECG telemonitoring unit of our project

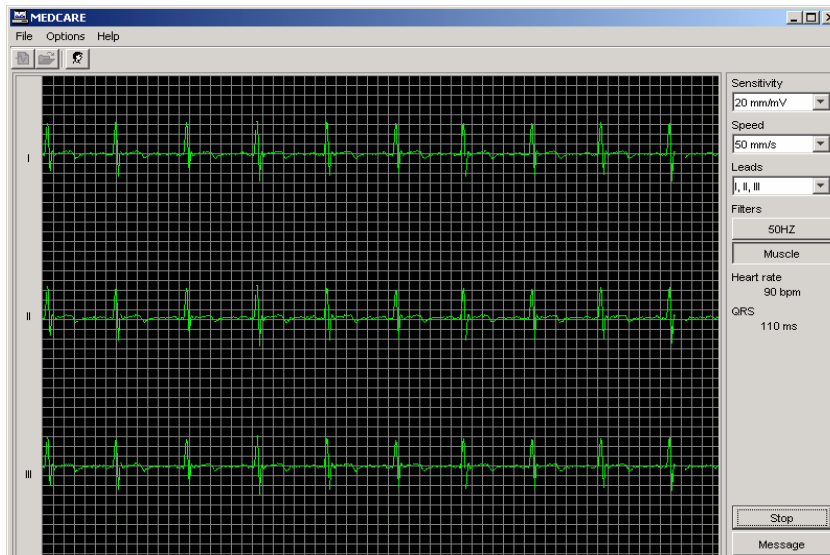

Fig. 3 User interface for 3 leads ECG acquisition and analysis

etc.) and storing to a compact flash memory, as a warning device during normal activity, or an exercise stress test.

The heart of the module is an 8-bit microcontroller (μ PSD3234A from ST Microelectronics). It has an 8032 compatible UCP capable of being clocked up to 40 MHz. The μ PSD has a memory structure that includes two independent Flash memory arrays, main (256 Kb) and secondary (32 Kb), capable of read-while-write operation. It also contains a large SRAM memory (8 Kb) on chip, with battery back-up option for RTOS and communication buffers. The other features of the μ PSD include: communication interfaces such as USB v1.1 Low Speed (1.5Mbit/s), I2C Master/Slave controller running up to 833 kHz, SPI Master controller, two UARTs with independent baud rate, IrDA Potocol up to 115 kbaud, 4-channel 8-bit A/D Converter and 5 PWM channels.

The Patient module is connected to a medical device such as WristClinic™ or MiniClinic™ via the USB connector and receives the data. An external USB camera can be connected to a secondary USB connector in order to receive images from the patient. Data can be stored temporarily on the μ PSD internal memory or in a Data Memory which is an external memory chip capable to store up to 32Kb.

The patient module offers the possibility to make an audio connection with the patient by using the microphone and the speaker connected to μ PSD through an external A/D and D/A converters.

The ETHERNET controller is RTL8019AS, one of the modern implementations of the NE2000 standard. It integrates 16 kBytes of SRAM, modulator and demodulator for the physical interface, Ethernet protocol controller, memory interface, and many other functions.

The data collected from the Medical devices, waveforms and parameters, can be displayed by using a popular graphical module (128 x 64 pixels) before sending them to a Telemedical Centre by using the Internet connection or by using the GSM Modem.

A. Software

The software working on the Patient Module collects the data from medical devices and video/audio sources, computes the parameters and displays them on the LCD Display activates the alarms and sends the results to the Telemedical Centre.

The device has as main features: real-time ECG / biosignal acquisition and processing, executes the operator's commands, monitors the system's overall performance, acts in emergency situations, and aids the diagnostic.

To make a simple software implementation, we choose to use the standard TCP/IP network protocol as the link provider, a scalable and economically feasible tool.

For DAQ applications in real-time, such as ours, one must use real time (RT), multitasking operating systems. A modern and economic solution is to choose an open source (free) RT-OS, such as RT-Linux. It is comprised of a small RT kernel which runs: (i) a C/C++ RT process at top priority, and (ii) the standard Linux kernel as a fully preemptable low priority task. High speed (low interrupt latency) and predictable timing are achieved by limiting the RT process to functions that are essential to real time.

B. ECG Acquisition and Processing

The most important ECG phases for morphological analysis are [1]:

- *P-wave* (representing contraction of the atria);
- *QRS complex* (representing contraction of the ventricles);
- *T-wave* (representing the recovery of the ventricles).

Typical ECG processing algorithms consist of the following steps:

a) Initialization - used to determine initial signal and timing thresholds, positive/negative peak determination, automatic gain control, etc.

b) Filtering - this is performed first as analog filter on ECG amplifier board, and then as digital filter on acquisition board. In addition, a 50 Hz notch filter is used to reduce power line interference.

c) QRS complex detection - reliable detection of R-peak is crucial for morphological analysis [3].

d) Baseline correction - compensates for low-frequency ECG baseline drift.

e) ST segment detection [6].

C. Detection of QRS Complexes

An adaptive thresholding technique with searchback serves as the primary method for QRS detection. The thresholds are based on the most recently detected signal and noise levels to react to changes in the patient's heart rate, as well as to signal and noise levels.

The QRS complex is the most significant feature in the ECG signal. Being characterized by sharp slopes, its duration is about 70 – 130 msec and its energy spectrum is mostly between 1 and 40 Hz. The input of the QRS detector is the digital ECG signal, sampled at 250 Hz and quantized with 12 bits/sample by A/D converter. The outputs are the limits of the QRS complex (QRS_{on} and QRS_{off}), the location of the R wave, and location of the QRS peaks and notches (if they exist) of every beat (complex) [4], [5]. The QRS detection algorithm consists of three steps: (1) coarse QRS limits determination; (2) peaks and notches determination, and (3) exact limits determination.

D. ST Segment Analysis

The ST-segment begins 40 msec after the R-peak in the event the heart rate is more than 100 bpm, or 60 milliseconds after the R-peak otherwise. ST-segment has normally a predefined length of 160 milliseconds. The normal ST-segment template is constructed for each patient as the average of the first ten normal ST-segments. Baseline drift is compensated according to the slope between the isoelectric levels of the two beats. Standard annotated databases, such as the European ST-T Database and the MIT/BIH Arrhythmia Database, provide means for algorithm evaluation. In order to compute ST-segment length, a T wave detector must be implemented [2].

TABLE I
COMPRESSION RESULTS FOR DIFFERENT SIZES OF THE TCP/IP BUFFER

Time (sec.)	Uncompressed size (bytes)	Compressed size (bytes)	Compression ratio (%)
10	60000	26592	55.7
9	54000	24125	55.3
8	48000	21681	54.9
7	42000	19027	54.8
6	36000	16541	54.1
5	30000	14061	53.2
4	24000	11502	52.2
3	18000	8904	50.7
2	12000	6123	49.2
1	6000	3205	47.0

TABLE II
ERROR RATE FOR DIFFERENT SIGNALS FROM MIT/BIH ARRHYTHMIA DATABASE

Nr.	Signal	Time (min)	PRD
1	No.100	1	6.2
		2	6.9
		3	7.2
2	No.201	1	6.3
		2	7.1
		3	7.9
3	No.107	1	2.1
		2	2.2
		3	2.4

TABLE III
MORPHOLOGICAL ANALYSIS OF A 12 LEADS ECG

Lead	Amplitude [μV]										Slope [$\mu\text{V/s}$]	Duration (ms)		
	P+	P-	Q	R	S	ST20	ST60	ST80	T+	T-	ST	Q	R	S
I	171	0	-76	877	-130	-11	-3	-3	320	0	250	18	42	24
II	248	0	-125	1302	-205	-17	-8	-8	474	0	750	18	42	24
III	77	0	-49	425	-76	-6	-5	-5	154	0	500	12	44	24
aVR	0	-209	0	100	-192	14	5	5	0	-397	-500	-	18	42
aVL	47	0	0	227	-28	-3	1	1	84	0	0	-	38	26
aVF	163	0	-87	864	-140	-11	-6	-6	314	0	750	18	42	24
VI	80	0	-46	451	-72	-6	-3	-3	160	0	250	14	44	24
V2	168	0	-88	908	-143	-12	-5	-4	327	0	750	18	42	24
V3	242	0	-126	1283	-205	-17	-9	-7	463	0	750	18	42	24
V4	375	0	-185	1945	-303	-24	-9	-9	712	0	1000	18	42	24
V5	247	0	-124	1305	-204	-17	-8	-7	477	0	500	18	42	24
V6	182	0	-79	918	-133	-11	-4	-3	338	0	500	18	42	24

E. Data Compression and Error Rate

Experiments revealed the necessity for data compression, in order to make a real-time ECG transmission. We used Linux Gzip programme, that yields about 2:1 average compression ratio by means of Lempel Ziv algorithm.

Table I presents results obtained for a resolution of 12 bits/sample and 250 Hz sampling rate, with 3 leads ECG. In this way, only 6 KB/s bit rate is enough for a real-time 3 leads ECG transmission!

The quality of data transmission was evaluated by computing PRD (percentage rate of distortion, a kind of root mean square), according to formula (1) below. Table II shows a PRD level under 10%, a value accepted by clinicians for expressing a correct diagnosis.

$$PRD = \sqrt{\frac{\sum_{n=1}^N [x(n) - \tilde{x}(n)]^2}{\sum_{n=1}^N x^2(n)}} \times 100 \quad (1)$$

III. RESULTS AND DISCUSSION

A. The whole telemonitoring system acts as a client-server application. The *server module* includes: a database server (using MySQL and open sources for server procedures, tables, restrictions coming from "client" application); an administration/control module that supervises general dataflow; an access/security module; a parameters configuration module a.s.o. Also, it uses HTML and HTTP to send most up to date information on heart care to clients.

B. The client module comprises the software working on the expert's computer. It is implemented by using Java applets and has the following facilities: GUI (Graphic User Interface) for ECG monitoring (Fig. 3); displays the patient's ECG in real-time and the extracted ECG segments data; communicates the experts' commands (e.g. remote selection of the ECG lead) and medical decisions to the physician/patient. Also, some off-line processing algorithms are implemented, such as: advanced filtering; morphologic ECG analysis (intervals, amplitudes, electrical axes), average complexes with measurement reference markings; heart rate variability analysis, etc.

We designed and prototyped the monitoring unit for acquisition and real-time ECG processing, the software implementation for the Internet connectivity (the embedded TCP/IP subsystem), and the software for displaying ECG information on the medical doctor's computer. The average reconstruction error of the ECG signal is about 4.6%. We also tested various algorithms for morphologic ECG analysis with good results on MIT/BIH Arrhythmia Database (Table III).

The utility of our system is as follows.

1. The monitoring

Medical monitoring – to watch the clinical / paraclinical parameters of a patient in order:

- (a) to decide upon a nosological, etiological or prognostic diagnosis and to make a treatment decision, or
- (b) to assess the efficiency / to correct a treatment plan.

2. Pre-diagnostic monitoring

It is used in order to establish a nosological, etiological or prognostic diagnosis, in the case of discrete, infra-clinical, atypical manifestations of diseases or for obvious signs in case of stress tests / daily conditions. A single parameter in conditions of interrupting the medication is monitored. E.g.: Holter monitoring of ECG in arrhythmias, arterial pressure in border hypertension syndrome.

3. After-diagnostic monitoring (I)

- (a) Vital functions monitoring: cardio-vascular, respiratory or vital nervous centers functions in case of:
 - shock syndrome (cardiac, hypovolemic, polytraumatic, septicemic, anaphylactic, post-combustion);
 - comas (traumatic, metabolic – hepatic, uremia, diabetic);
- (b) only in emergency hospital services, in situations that needs a rapid therapeutic reaction;
- (c) multi-parameters monitoring devices with alarm systems released by pathological patterns or critical values of: heart or respiratory rate, oxygen saturation, central arterial or venous pressure.

4. After-diagnostic monitoring (II)

- Treatment monitoring – posology:
 - establishes the dose or the efficiency a drug;
 - establishes the circadian rhythm of maximum effect of a drug;
 - establishes the secondary effects or adverse effects, or effects of association the drugs;
 - it is monitored the improving of functional parameter under treatment and it make the decision to change the drug or to modify the dose;
 - e.g., respiratory flows MEF50, FEV1 under β -agonist treatment in Bronchial Asthma; arterial tension after anti-hypertension drugs.

5. After-diagnostic monitoring (III)

- (a) Monitoring the recovery and the maintenance of remaining functions:
 - cardiac, respiratory, (Insufficiency Syndromes) or
 - locomotion (lack of force / articular mobility – dynamometry, goniometry).
- (b) Monitoring the recovery with specific functional stress testing: cycloergometer treadmill.
- (c) Alarm feedback mechanism to watch the level of effort and risk of decompensation.

6. Special monitoring

- Telemetric monitoring for– Psychiatric patients (dementia with dromomania);
- Persons in extreme environment with physical stresses (deserts, under water, extra-terrestrial, calamities);
- Sportsmen training;
- Periodical monitoring the health status.

- [7] European Commission, Information Society Technologies Directorate-General, "Resource Book of e-Health Projects – 6th R&D Framework Programme, 2002-2006".
- [8] European Commission, Information Society Technologies Directorate - General, "Applications Relating to Health– 5th R&D Framework Programme, 1998-2002".

IV. SUMMARY AND CONCLUSION

Real time personal ECG monitoring, as an important application of telemonitoring system, requires devices with high peak performance and low power consumption. High performance of RT-Linux development environment allows high speed multitasking procedures and real time signal processing. The proposed system could be used as a warning system (Holter-type) for monitoring of arrhythmia or ischemia during normal activity or physical exercise. In addition to monitoring of physiological signals, we plan to use the proposed environment for development of a high performance user interface. New user inputs, including correlates of the user's physiological and emotional states could significantly improve human-computer interface and interaction. Many algorithms for ECG analysis have already been tested with very good results. Moreover, our monitoring system is general enough to enable a wide range of biosignals monitoring and analysis, e.g. ECG, EEG, EMG a.s.o.

ECG tele-monitoring of a patient in real time, according to our project, has as main feature the analysis and transmission of the patients' bio-signals through the Internet, so that experts in cardiology could make the right diagnostic. So, by using the existing web-based and embedded technologies, the quality of medical decision in tele-healthcare and emergency medical services systems can be significantly improved.

ACKNOWLEDGMENT

This work is supported by a two-years grant from the Romanian Ministry of Education and Research, within CEEX program (www.mct-excelenta.ro), contract No. 604/645/21.10.2005.

REFERENCES

- [1] A. Cohen, "Biomedical signal processing", in A. Prochazka, *et al.* (eds.), *Signal Analysis and Prediction I*, EURASIP, ICT Press, Prague, 1997.
- [2] P. Laguna, *et al.*, "New algorithm for QT interval analysis in 24-hours holter ECG: performance and applications", *Med. Biol. Eng. Comput.*, Vol.28, Jan. 1990, pp. 67-73.
- [3] J. Pan, W.J. Tompkins, "A real-time QRS detection algorithm", *IEEE Transactions on Biomedical Engineering*, Vol. 32, No. 3, March 1985, pp. 230-236.
- [4] D.L. Rollins, *et al.*, "A telemetry system for the study of spontaneous cardiac arrhythmias", *IEEE Transactions on Biomedical Engineering*, Vol. 47, No. 7, July 2000, pp. 887-892.
- [5] A. Ruha, *et al.*, "A real-time microprocessor QRS detector system with a 1-ms timing accuracy for the measurement of ambulatory HRV", *IEEE Trans. on Biomedical Engineering*, 44, No. 3, 1997, pp. 159-167.
- [6] V. Subramanian, "Clinical and research applications of ambulatory Holter ST-segment and heart rate monitoring", *The American Journal of Cardiology*, Vol. 58, No. 4, 1986, pp. 11B-20B.