

Tool for Helping Rural Woman Giving Birth

Bernadus Kristyanto, Luciana T Dewi, Rustamaji

Abstract—Giving birth is a natural process and most women have to go through it. Gynecologist or Midwife usually uses the leg holder to position the cervix in the stitching process. In some part of rural areas in Indonesia, the labor process normally being done at homes by calling in a midwife or gynecologist. The facilities for this kind of labor process is not yet sufficient, as the use of leg holder supposedly on the obstetric bed. The reality is that it is impossible to bring in the obstetric bed to the patient's house at the time they call for giving birth or the time when the stitching of the cervix need to be done. This research is redesigning the leg holder through Biomechanics and ergonomic approaches to obtain the optimal design which is suitable to the user of a developing country such as Indonesia.

Keywords—Giving birth, Leg holder, Re-design product, Biomechanics and ergonomic approaches

I. INTRODUCTION

GIVING birth needs extra physical condition that is crucial for a smooth process of birth. Most people have an assumption that birth position is only lying down (lay back) or semi seated. There aren't any best positions for giving birth. The most convenient position for the mother when giving birth is the only best position but normally doctors or midwives always ask the patients to lie down or half seated. Lying down position (lithotomic) is a position where the mother lies on the obstetric bed with both of the legs straddle and hanging on the legs holder. This is a good position for the doctor to help the birth process. The baby's head is easy handed on the right direction. However, this position makes the mother difficult to push the baby out due to the gravity of the mother on the bottom and parallel with baby's position. Semi seated position is a position where the mother sits on the obstetric bed with the back supported by a pillow and both of her legs are opened. This position is more convenient and makes the baby's way out shorter and provides good oxygen supply for the fetus. However, this position makes the mother feel tired and can cause back injuries. Here the leg holder tool plays a crucial role in the birth process. The tool will keep both of the legs open and help the baby to find an easy way out. Moreover midwives (doctors) can easily monitor the progress of birth process and also help to give the right position for the stitching process of the cervix tearing is needed. In some part of the rural areas in Indonesia, the labor process is normally done at home by calling in a midwife or a gynecologist. The facilities for this kind of labor process is not yet sufficient, as the use of the leg holder was supposed to be on the obstetric bed. The reality is that it is impossible to bring in the obstetric bed to the patient's house at the time of birth. The problems are about the location of the patient's house and the transportation of the obstetric bed. Sometimes it is not easy to reach their house by a car or deliver an ambulance. To solve this problem a previous research of flexible design for obstetric bed in a form of portable leg holder has been developed by Kristyanto B and MR. Widhiandani [1].

Dr. Kristyanto is with Atma Jaya Yogyakarta University, Indonesia e-mail: b.kristyanto@mail.uajy.ac.id

The Leg holder tool obtained satisfying analysis and it improved safety and convenient feeling for both patient and midwife (doctor) when the stitching process has been done. Unfortunately the existing leg holder was not strong enough when it was used by the mother for straining (push-ejan). The leg holder tool which has compatible structure to anticipate the rolling moment of force from the straining mother is required to be redesigned. The objectives of this study is to redesign the ergonomic portable leg holder tool which has enough strength of structure from the rolling effect and keep both of the patient's legs in open position (straddle position) during the labor process. For this purpose the 2 scenarios of biomechanics postures models are developed for study. The first is the lying down posture position, and the second is half sitting posture position.

II. METHOD AND ANALYSIS

A. Anthropometric Data Observation

For designing the product an anthropometric data from the population are needed and collected. The data was measured from the populations which are pregnant woman (mothers) patients in Panti Rapih Hospital in Yogyakarta, Indonesia. A thirty data of anthropometric pregnant woman were sampled to be collected. The respondents were 25 year to 35 years old with 23 to 39 weeks of pregnancy. The respondents were from a pregnant exercising community in Panti Rapih hospital. The anthropometric data of Indonesian pregnant woman from the previous research of Kristyanto and Widhiandani were collected from Batu Ampah Puskesmas (Community Health Centre) in the suburb of Dusun Tengah, Kalimantan Tengah. The main variable anthropometric data from both populations that are required for designing the product are similar.

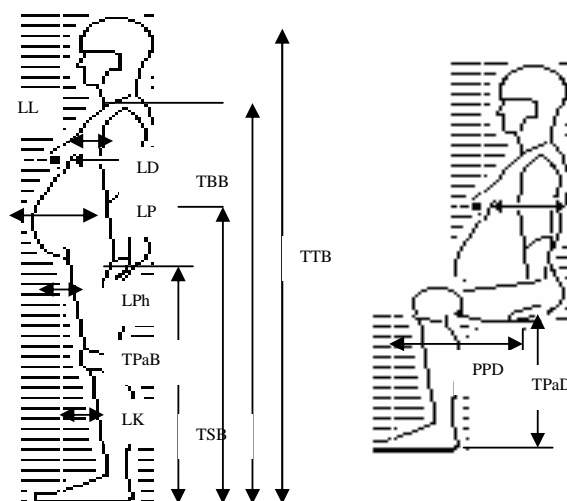

Fig. 1 Standing and sitting postures (adopted and modified from Rutter B, et. al) [2]

In designing the first portable leg holder (binhower), it needed dimensions of anthropometry, which are Knee Height (KH), Thigh Thickness (TT), Chin Height (CH), Waist Wide

(WW), Popliteal Sitting Height (PSH), and Buttock to Popliteal (BP). These dimensions were chosen based on each of its own function in designing the portable leg holder (binhower) [2]. The first portable leg holder is shown at Fig.2. and Table 1 showing the anthropometric data for designing this tool.

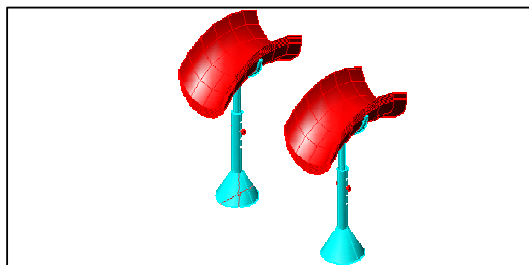

Fig. 2 The First Leg holder (Binhower)

TABLE I
ANTHROPOMETRIC DATA FOR DESIGNING THE FIRST PORTABLE LEG HOLDER
PRESENT IN PERCENTILES

Dimension	Percentil Scores (cm)		
	5 th	50 th	95 th
CH	7,45	11	14.55
TT	14	16	19
KH	34	36	39
WW	33	36	40.1
PSH	26.1	30	39
BP	11,6667	13	14,5167

B. Redesigning the Product Based On the Anthropometric Data

Based on the anthropometric data and the previous model of product that has been developed [1], the leg holder product is redesigned. Fig. 3 shows the establishing function of the present product by modifying the existing function of the previous one.

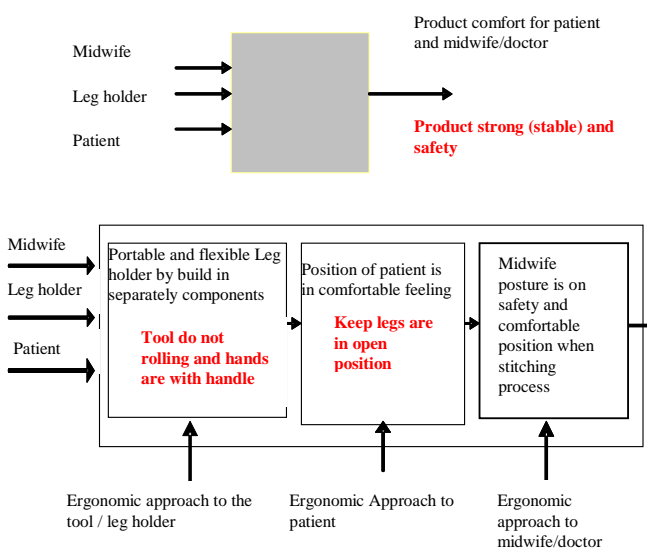

Fig. 3 Establishing function by modified the existing function

Based on the establishing function the first leg holder tool is needed to be redesigned by improving the structure of frame. Both left and right hands of tool holder should be designed to connect with each other. This connection will make the construction of the tool become stronger. Here the dimensions that should be determined are the tool wide, length, and height. Dimensions of anthropometric which are involved in the design are Waist Wide (WW), Buttock to Knee (BK), Popliteal Thickness (PT), and Popliteal Circumference (PC) as shown in Table II.

TABLE II
ANTHROPOMETRIC DATA REQUIRED FOR DEFINING NEW PRODUCT SPECIFICATIONS

data	Percentile (cm)		
	5%	50%	95%
WW	35,8	39	44,6
BK	43	47,25	52
PC	32	38	42
PT	10,2	12,1	13,4

Determining the height of Leg holder tool:

$$\begin{aligned} \text{Minimum height} &= \text{BK (5\%)} - \text{PT (50\%)} \\ &= 43 - 12,1 \\ &= 30,9 \text{ cm} \end{aligned}$$

$$\begin{aligned} \text{Maximum height} &= \text{BK (95\%)} - \text{PT (50\%)} \\ &= 52 - 12,1 \\ &= 39,9 \text{ cm} \end{aligned}$$

Determining the Length of the tool:

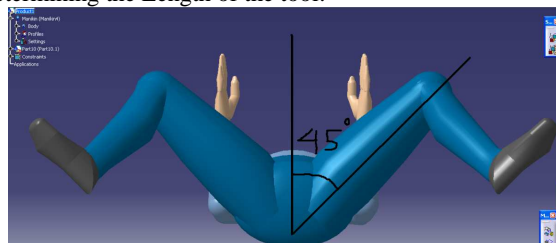
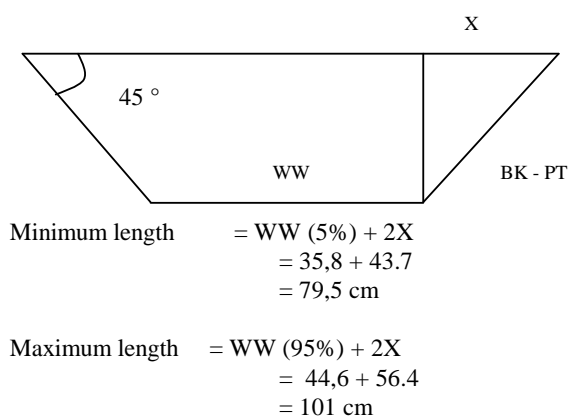

Fig. 4 The maximum degree of legs in open positions



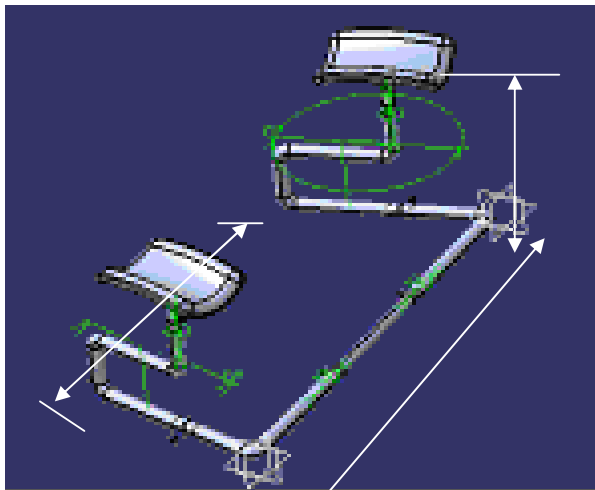

Fig. 5 Designing Product (Leg holder tool)

C. Reposition Based On Two Scenario Models

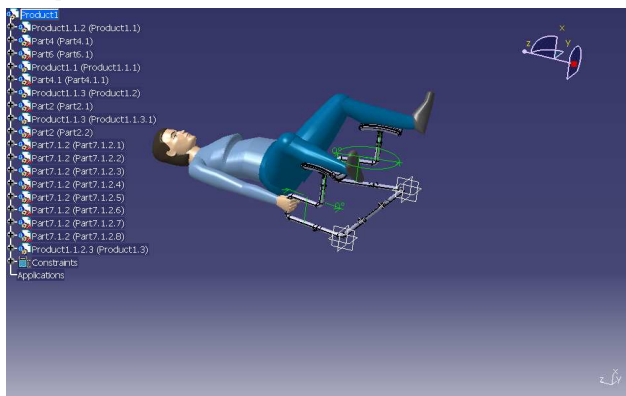

Fig. 6 Lying down position

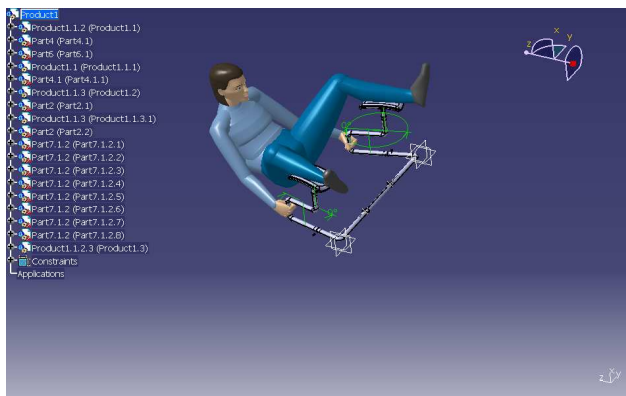

Fig. 7 Half seated position

III. RESULTS AND DISCUSSION

Step A and B produced the product and it is the portable Leg Holder Tool. These tool dimensions were defined by an anthropometric data and its width and height which can be adjusted. The tool has a hand pulling part on both sides. Then when the mother does the straining for pushing the baby out, this part is very useful to balance the force.

Step C is the content of biomechanics analysis between human interactions with the tool which has 2 scenarios position analyses. Under Biomechanics analysis on single activity analysis using CATIA programming software the two scenarios position are compared as shown in Table II.

From Table III, shows better results on the Lying down position than on half sitting position. Only on part of the Body Load Compression the value of Lying down Position is greater than Half Sitting Position. This load impacts to the baby and makes the mother to need extra straining to push out the baby.

TABLE III
BIOMECHANICS ANALYSIS COMPARISONS BETWEEN TWO SCENARIO POSITIONS

Analysis	Value	
	Lying down Position	Half sitting Position
L4-L5 Moment (Nm)	15	52
L4-L5 Compression (N)	580	1034
Body Load Compression (N)	312	175
Axial Twist Compression (N)	1	0
Flex/Ext Compression (N)	257	859
L4-L5 joint shear	41	191
Abdominal Force (N)	1	13
Abdominal Pressure (Nm2)	0	0
Ground reaction (N)		
Total (X)	0	0
Total (Y)	0	0
Total (Z)	631	631
Left foot (X)	0	0
Left foot (Y)	0	0
Left foot (Z)	316	316
Right foot (X)	0	0
Right foot (Y)	0	0
Right foot (Z)	316	316

If the RULA Analysis method is also used for completing analysis than Table 4 shows this comparison based on CATIA Human Factor Analysis.

TABLE IV
RULA ANALYSIS COMPARISON BETWEEN TWO SCENARIO POSITIONS

Analysis	Scores			
	Lying down Position		Half sitting Position	
	L	R	L	R
Final (Total)	3	3	6	6
Upper Arm	1	1	2	2
Fore Arm	2	2	2	2
Wrist:	3	3	3	3
Wrist Twist	1	1	1	1
Posture A	3	3	3	3
Muscle	1	1	1	1
Force/load	0	0	0	0
Wrist and Arm	4	4	4	4
Neck	1	1	1	1
Trunk	2	2	0	0
Leg	1	1	1	1
Posture B	1	1	9	9
Neck, Trunk and Leg	2	2	10	10

RULA analysis also gives better score results for position 1 than position 2. Based on position 1 or Lying down position, this position is more acceptable with score level (3) for giving birth than position 2 that is Half Sitting Position with score

level (6). For other implementation such as for midwives or doctors, further researches and investigations are still running in program under The Government grand in Atma Jaya Yogyakarta University, Indonesia.

IV. CONCLUSION

By step A and step B the prototype of Leg Holder tool has been built and still under investigation for implementation. To obtain better results for developing the product a progressive method is needed in applying the tool in rural area that are poor of facilities.

REFERENCES

- [1] Kristyanto B and Widhiandani MR, 2011, *Designing Portable Binhowser*, Int.Conf Proceeding of Industrial Engineering and Service Science, Solo, Indonesia
- [2] Rutter B, Haager JA, Daigle GC, 1985, An Anthropometric Study of Pregnant Woman: a HyperCard Stack, Proceedings of the International Conference on Occupational Ergonomics.