

Effect of Mass on Bus Superstructure Strength Having Rollover Crash

Mustafa Bin Yusof, Mohammad Amirul Affiz Bin Afripin

Abstract—Safety of bus journey is a fundamental concern. Risk of injuries and fatalities is severe when bus superstructure fails during rollover accident. Adequate design and sufficient strength of bus superstructure can reduce the number of injuries and fatalities. This paper deals with structural analysis of bus superstructure undergoes rollover event. Several value of mass will be varied in multiple simulations. The purpose of this work is to analyze structural response of bus superstructure in terms of deformation, stress and strain under several loading and constraining conditions. A complete bus superstructure with forty four passenger's capability was developed using finite element analysis software. Simulations have been conducted to observe the effect of total mass of bus on the strength of superstructure. These simulations are following United Nation Economic Commission of Europe regulation 66 which focuses on strength of large vehicle superstructure. Validation process had been done using simple box model experiment and results obtained are comparing with simulation results. Inputs data from validation process had been used in full scale simulation. Analyses suggested that, the failure of bus superstructure during rollover situation is basically dependent on the total mass of bus and on the strength of bus superstructure.

Keywords—Bus, Rollover, Superstructure Strength, UNECE Regulation 66,

I. INTRODUCTION

NOWADAYS, highway traffic safety is a very important issue over the world. Everyday a noticeable number of vehicles are facing different types of accidents. Rollover is one of the severe accident conditions. Accident due to rollover is very frequent over the world. Most rollover crashes occur when a vehicle runs off the road or rotates sideways on the road by ditch, curb and soft soil or by some other objects. In most of the rollover accidents of buses, its superstructure faces strong impact with the surface of road. This impact leads to collapse of bus roof resulting severe injury to the occupants and extreme damage to the frame of bus. National Highway Traffic Safety Administration (NHTSA, 2002 b) USA reported that only about 3% of all crashes are rollovers that caused 33% of total crash related deaths. Rollover may be of different types depending on the reasons that commence it. It includes trip-over, fall-over, flip-over, bounce-over, turn-over, collision with another vehicle, climb-over, end-over-end etc.

Mustafa bin Yusof is Associate Professor in Mechanical Engineering Department, Universiti Teknologi Malaysia, Skudai, Skudai-81310, Johor, Malaysia (phone: +60137209560; e-mail: mustafa@fkm.utm.my).

Mohammad Amirul Affiz bin Afripin, B. Eng (Mech.) II Year Student, Mechanical Engineering Department, Universiti Teknologi Malaysia, Skudai, Skudai-81310, Johor, Malaysia. (e-mail: amirul_affiz@yahoo.com).

Kecman, D. and Tidbury, G. H. [1] presented a pioneer research on the process of calculating different parameters for the certification of rollover related issues which was accepted as a base of United Nations Economic Commission for Europe (UN-ECE) Regulation 66. White, D. M. [2] worked on the Rollover Accident Simulation

Program (RASP) developed to study the design factors which affect rollover stability. The height of CG was the most critical factor affecting the damages in rollover accidents. Kumagai et al., [3] simulated a full scale bus using FEA program meeting the requirements of ECE 66. The results were compared with that of full scale dynamic rollover test of a bus.

Kecman, D. and Dutton, A.J. [4] described the design of seats to meet both the ECE Regulation 80 and the ADR 68, still now it is commercially feasible in terms of weight and cost. Kecman, D. and Randell, N. [5] studied on the methods of structural design by ECE Regulation 66. Both Quasi-static and full dynamic analysis of the rollover test can be used for the development of the structure. Botto et al. [6] described an analysis of eleven rollover accidents from a sample of seventy eight bus collisions occurred in France. The 41% of all accidents was found as rollovers.

Rasenack et al. [7] presented a survey of bus collision between 1985 and 1993 in Germany. Very few of the collisions resulted to rollovers accounting 50.2 % of all severe injuries and 90% of all fatalities. Characteristics of on-road rollovers regarding steering wheel angle amplitude, steering wheel rate, lateral acceleration, yaw rate, body roll angle and roll rate were presented by Marine et al [8]. Roper, L. David [9] studied the effect of lateral speed, height of the center of gravity and different types of road surfaces numerically in his detailed work to investigate the reasons of rollover that helps to initiate rollover. Ferrer, I. and Miguel, J. L. [10] presented a report on the reasons of fatalities during rollover accidents of high speed buses. That research concluded that, most of the fatalities were caused due to ejection of passengers from bus and impact with bus interior. The mitigation of rollover injuries by increasing roof strength using A-pillar, roof rail and header intersection was assessed by Bish, Jack et al. [11]. Their work suggested improve the strength of roof sufficiently to prevent roof crash during rollover that might decrease the degree of fatalities.

Therefore, no research has been carried out on the Strength of Bus Superstructure to Prevent Rollover Crash of bus frame. Most of the works were related to the surveying of the number of fatalities and injuries. Some of the researches have been conducted to analyze the reasons of rollover. The effect of rollover on the superstructure of bus and the detailed analysis of that is very important to decrease the extremity of damages on both of the occupants and the bus frame. This research presents a numerical study on the effects of total mass of bus and the strength of bus superstructure on the safe residual space in bus during rollover accident.

II. METHODOLOGY

The effects of initial impact of rollover on bus superstructure can be investigated in several ways. This study includes finite element analysis simulation of bus frame to observe the effects of mass and the strength of bus superstructure on the deformation and stress in the superstructure during rollover simulation according to UN-ECE Regulation 66. Superstructure of bus frame refers to the part of bus structure that carries the impact load during rollover process.

A. Residual Space Defined by UNECE Regulation 66

According to UN-ECE Regulation 66, a bus design can be approved for fabrication if the superstructure of the bus is strong enough to maintain safe residual space inside the bus for occupants during rollover situation. The envelope of the vehicle's residual space is defined by creating a vertical transverse plane within the vehicle which has the periphery described in Fig. 1 and moving this plane through the length of the vehicle as shown in Fig. 2.

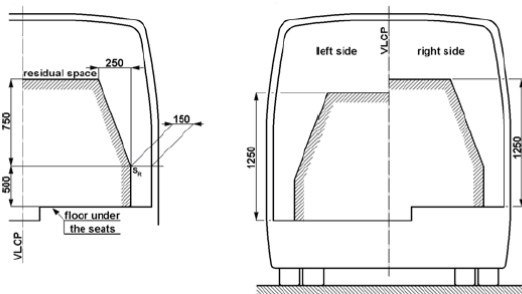

Fig. 1 Lateral arrangements of residual space inside the bus

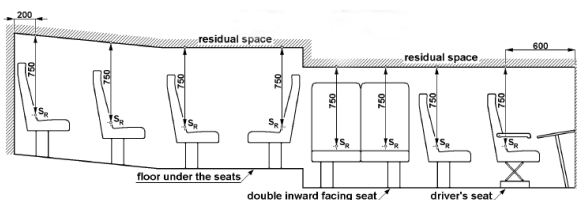

Fig. 2 Longitudinal arrangements of residual space inside a bus

The S_R (Residual Space) point located on the seat-back of each outer forward or rearward facing seat (or assumed seat position) is 500 mm above the floor under the seat and 150 mm from the inside surface of the side wall. These dimensions can also be applied in the case of inward facing seats in their center planes. If the two sides of the vehicle are not symmetrical in respect of floor arrangement and, therefore, the height of the S_R points, the step between the two floor lines of the residual space shall be taken as the longitudinal vertical center plane of the vehicle (Fig. 1).

The rearmost position of the residual space is a vertical plane 200 mm behind the S_R point of the rearmost outer seat. The foremost position of the residual space is a vertical plane 600 mm in front of the S_R point of the foremost seat (whether passenger, crew, or driver) in the vehicle set at its fully forward adjustment. If the rearmost and foremost seats on the two sides of the vehicle are not in the same transverse planes, the length of the residual space on each side is to be different. The residual space is continuous in the passenger, crew and driver compartments between its rearmost and foremost plane and is defined by moving the defined vertical transverse plane through the length of the vehicle along straight lines through the S_R points on both sides of the vehicle.

B. Validation of Simulation Inputs

1) Simulation of Box Model

A simplified model of bus was modeled using finite element analysis software to conduct rollover simulation. The model was designed in such a way that, it consists of the same type of structural characteristics of a practical bus frame. The simplified model was designed with the intension to perform practical rollover test on the same model fabricated by the researcher. The dimensions and three dimensional view of the box model are given in Table 1 and Fig. 3.

Length of model	1 m
Width of model	0.5 m
Height of model	0.75 m
Height of ditch	0.8 m

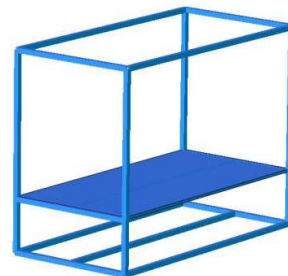

Fig. 3 Three-dimensional view of the box model used in simulation

The properties of mesh used in box model simulation and full scale bus simulation are given in Table II.

Element library	Standard
Family	Beam
Geometric Order	Linear
Beam type	Shear-flexible
Linear bulk viscosity scaling factor	1.0
Quadratic bulk viscosity scaling factor	1.0
B31	A 2-node linear beam in space

The effect of first impact on the box model due to rollover on the surface was observed. The magnitude and location of maximum strain obtained from the result of simulation are given in Fig. 4. The magnitude of maximum deformation was obtained as 1.947×10^{-3} m (1947 micrometer) and its location was at the superstructure of bus model as shown in Fig.4.

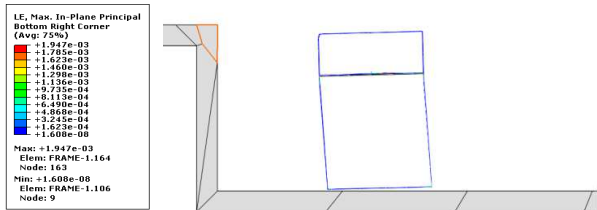

Fig. 4 Maximum deformation of box model during rollover motion

2) Rollover Experiment of Box Model

A box model was fabricated with the same dimensions and material properties (Fig.5) of the model used in the simulation. Rollover test was carried out on the model meeting all of the necessary requirements of UN-ECE regulation 66. The strain and the motion of rolling over of the model were observed during the experiment. To get accurate result of dynamic strain, a sophisticated dynamic strain measuring system was used to measure strains at four different positions on the box model as shown in Fig. 5. A high speed video camera was used to record the video of rollover motion.

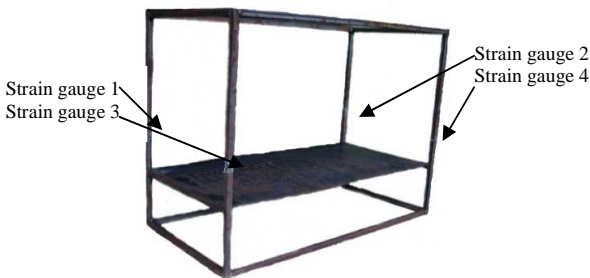

Fig. 5 The box model used in rollover experiment

The plot of the data obtained from four strain gauges of dynamic strain measuring system is given in Fig.6.

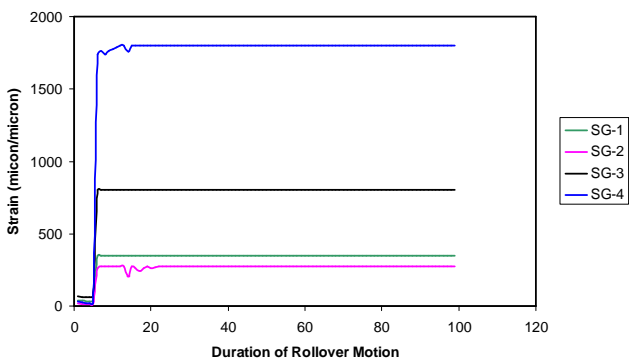

Fig. 6 The plot of strain obtained from dynamic strain measuring system

It is found that, the box model was subjected to a maximum strain of 1801 μ m as shown in Fig. 6. The maximum strain was found at the superstructure of the box model. The magnitude and the position of the maximum strain were found at the same position of superstructure compared to the box model simulation. The magnitudes of maximum strain obtained from box model simulation and experiment are very close to each other. Hence, it can be concluded that the inputs of box model simulation were accurate. The same inputs were used in the simulations of full scale bus which proves that the results of bus simulations are also accurate.

C. Modeling

A complete bus structure was modeled to analyze meeting the requirements of UN-ECE Regulation 66 as shown in Fig. 7 and Fig. 8. The passenger capacity of the bus is forty-four in all simulations. The bus was modeled neglecting the masses due to steel sheet to cover the bus frame and glass of all applications. The distributed loads of engine, different electromechanical fittings, instrument box, air-conditioner etc. were assumed as dead loads like tetrahedron. The air-conditioner load was assumed only on top of the roof. All of the beams and columns were modeled as beam elements. Since, dead loads are of no interest of analysis; those were defined as rigid bodies to reduce computational time.

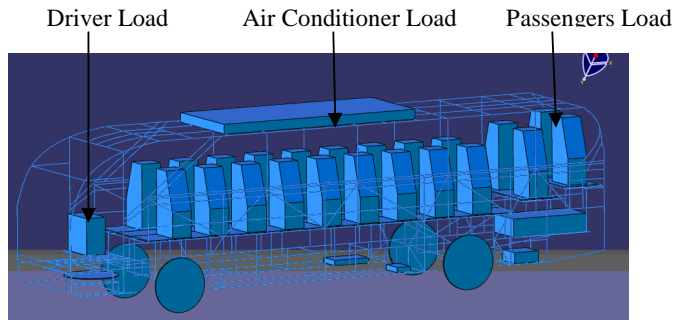

Fig. 7 The isometric view of bus structure used in simulation

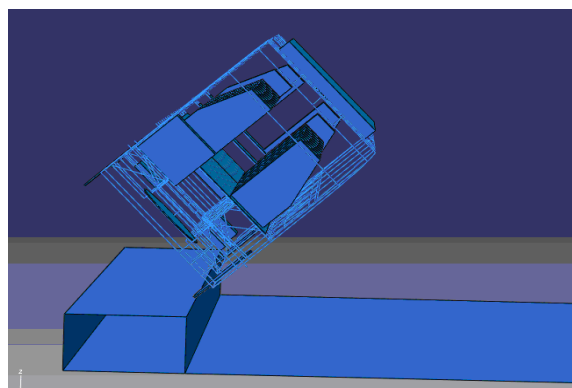

Fig. 8 The isometric view of bus placed on the ditch as an unstable condition before simulation

Since the superstructure faced impact with the ground and the effect of this impact was the main observation of simulations, small mesh size was used in the superstructure.

In contrast, bigger mesh sizes were used in the parts of bus structure having no impact with ground surface.

III. RESULTS OF SIMULATION

Most of the bus coach builders use the design of chassis from some renowned manufacturers like Hino, Nissan, SCANIA and etc. but for superstructure and different dead loads like air conditioner unit, battery, fuel tank, spare tire, floor and passengers' seats, they use their own design. Hence, it is necessary to carry out rollover test on the bus superstructure before fabrication. A total of four simulations have been performed on the bus design given by manufacturer. These are:

- a) Simulation of Bus Given by Manufacturer
- b) Simulation of Bus Given by Manufacturer with nineteen percent more Load
- c) Simulation of Bus Given by Manufacturer with thirty six percent more Load
- d) Simulation of Bus with Increased Strength of Superstructure

The results of Bus simulations changing different masses and strength of superstructure are explained in the following subsections.

A. Simulation of Bus Given by Manufacturer

The main specification of the bus is given in Table III and Table IV.

TABLE III
SPECIFICATION OF DIMENSIONS OF BUS

Dimension	Magnitude (m)
Length	11.14
Width	2.2
Height	2.86
Dimensions of different profiles used in superstructure	50 mm × 50 mm × 5 mm L-profile 50 mm × 50 mm × 5 mm box profile 38 mm × 38 mm × 5 mm box profile
Types of beams and columns	Fixed-fixed end conditions

TABLE IV
TYPES OF MAJOR MASSES OF BUS AND THEIR QUANTITIES

Name of Load	Mass (Kg.)
Air conditioner unit	80
Fuel tank	139
Engine	257
Floor and seats	2022
Others	1602
Total mass	4100

Result of simulation showed small deformation of superstructure as shown in Fig. 9. The bus frame was subjected to a Mises stress of 294 MPa at its superstructure, which is more than the yield strength of mild steel. Hence, the bus superstructure was subjected to a small plastic deformation. But the bus superstructure did not protrude in the safe residual space for passengers. Therefore, the bus was capable to preserve safe residual space for passengers' according to UN-ECE Regulation 66 which can be recommended for fabrication.

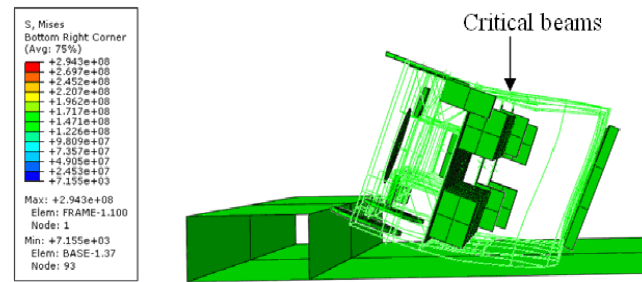

Fig. 9 The critical situation of bus superstructure during first impact of rollover

B. Simulation of Bus Given By Manufacturer with Nineteen Percent More Load

Since the bus explained in section 3.1 was capable to preserve safe residual space for passengers, another simulation was performed with increased total mass. The total mass was increased by increasing the mass of all parts except the bus structure. This analysis was performed to observe the effect of total mass of bus on its superstructure during rollover accident. The different masses and the dimensions of the main members of superstructure are given in Table 5 and Table 3 respectively. The total mass of bus was increased by 19 % (779 Kg).

TABLE V
QUANTITIES OF MAJOR MASSES OF BUS

Name of Load	Mass (Kg.)
Air conditioner unit	136
Fuel tank	162
Battery	63
Engine	694
Floor and seats	2746
Others	1078
Total mass	4879

Result of simulation showed that the bus structure was subjected to more deformation of superstructure during first impact compared to the bus of total mass 4100 kilograms. But the bus superstructure did not protrude in the safe residual space. Therefore, the bus structure was capable to preserve safe residual space for passengers' during rollover according to UNECE Regulation 66 as shown in Fig. 10.

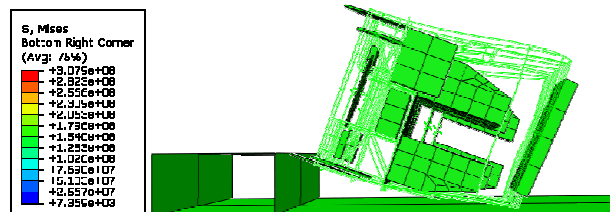

Fig. 10 The critical situation of bus superstructure during first impact of rollover

C. Simulation of Bus Given By Manufacturer with Thirty Six Percent More Load

To observe the effect of total mass of bus, another simulation was performed with increased total mass. The total mass of bus was increased by 36 % (1476 Kilograms) compared to the initial mass (4100 Kg.). The important dimensions of the bus used in this simulation are given in Table III and the new values of different masses are given in Table VI.

Name of Load	Mass (Kg.)
Air conditioner unit	210
Fuel tank	253
Engine	500
Passengers, seats and floor	3636
Others	977
Total mass	5576

Result of simulation showed large deformation of bus superstructure as in Fig. 11. The deformation was such that the bus superstructure could not preserve safe residual space for passengers. The bus frame was subjected to a very high Mises stress of 335 MPa which is more than the yield strength of mild steel. This excessive stress caused some plastic deformation in the bus frame and the superstructure protruded in the residual space. Hence, the strength of superstructure was not sufficient to fulfill the requirements of safe residual space regarding UN-ECE Regulation 66.

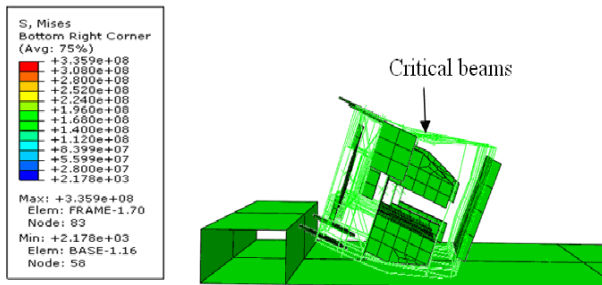

Fig. 11 The critical situation of bus superstructure during first impact of rollover

D. Simulation of the Bus with Increased Strength of Superstructure

Previous simulations showed that, superstructure is the most critical part of bus structure regarding rollover phenomenon. Since the strength of bus superstructure of the bus used in simulation of section 3.3 was not sufficient to preserve safe residual space, another simulation was performed with increased dimension of the cross sections of superstructure's members that increased the strength of superstructure. The important dimensions and different masses of the bus used in this simulation are given in Table VII and Table VIII. The beams of changed dimensions are shown in Fig. 12 labeled by 1, 2 and 3. The new dimensions of beams labeled by 1, 2 and 3 are shown in Table VII.

Dimension	Magnitude (m)
Length	11.14
Width	2.2
Height	2.86

Changed dimensions of different members used in superstructure

- (1) 65 mm × 65 mm × 5.2 mm L-profile
- (2) 65 mm × 65 mm × 5.2 mm box profile
- (3) 49.4 mm × 49.4 mm × 5.2 mm box profile

Types of beams and columns Fixed-fixed end conditions

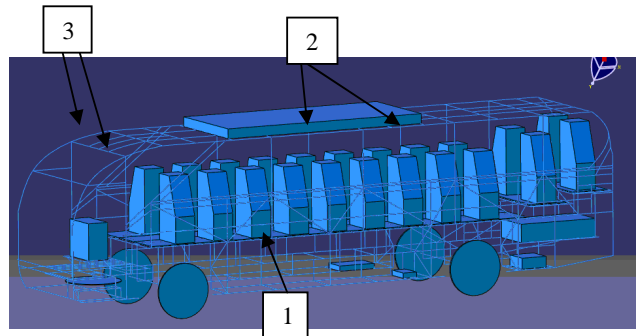

Fig. 12 Change in cross sectional dimensions of indicated and similar to those members

Name of Load	Mass (Kg.)
Air conditioner unit	210
Fuel tank	253
Engine	500
Passengers, seats and floor	3660
Others	1007
Total mass	5630

The width and breadth of some members (members 1, 2 and 3 in Fig. 12) of superstructure were increased by thirty percent and the thicknesses of those members of were increased by 0.2 mm. The simulation showed comparatively less deformation (Fig. 13) of superstructure compared to the deformation shown in Fig. 11.

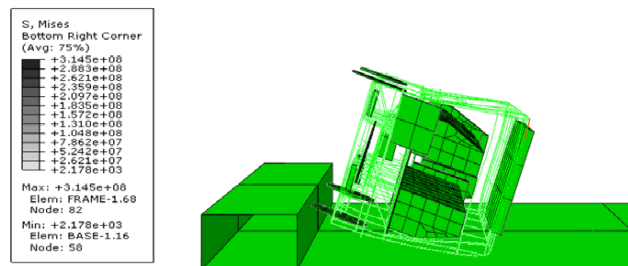

Fig. 13 The deformation of bus superstructure during first impact of rollover with increased strength of superstructure

The bus frame was subjected to a Mises stress of 314 MPa which is more than the yield strength of mild steel. This stress caused some permanent deformation in the bus frame.

But the bus superstructure did not protrude in the safe residual space for passengers. The deformation was such that the bus superstructure was capable to preserve safe residual space for passengers as shown in Fig. 13. Hence, the strength of the superstructure was sufficient to fulfill the requirements of residual space of UN-ECE Regulation 66.

IV. DISCUSSION

The simulation of the full scale bus was carried out by varying total mass of bus and the strength of superstructure.

The finite element analysis simulation showed that, maximum deformation occurs during its first impact. Fig. 14 showed the plot of maximum Mises stress versus total mass of bus and Fig. 15 showed the position of deformed superstructure and residual space in the bus.

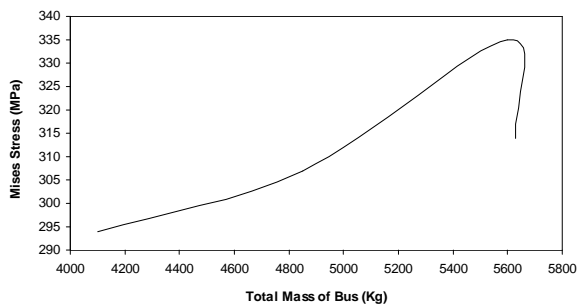

Fig. 14 Variation of maximum stress with total mass of bus

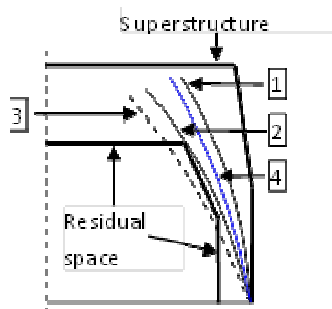

Fig. 15 Position of bus superstructure at maximum deformation during first impact

Fig. 14 showed that the magnitude of maximum stress of bus increased with increasing total mass except for the bus of mass 5630 Kilograms due to the fact that it is from different category of structure. The bus of mass 4100 kilograms was subjected to a maximum stress of 294 MPa. The simulation showed less deformation of superstructure (position 1 in Fig. 15) which was capable to maintain safe residual space during first impact. Then the mass of bus was increased by 19 % which was subjected to a maximum stress of 307 MPa showing only 4.42 % increase in stress. The simulation of this bus showed more deformation of superstructure during first impact (position 2 in Fig. 15) and the superstructure was just touching the boundary of safe residual space. Again the mass of bus was increased by 36 % compared to the initial mass of 4100 kilograms.

This bus showed a maximum stress of 335 MPa with an increase of 13.94 % stress. The simulation showed very large deformation of superstructure (assumed position 3 in Fig. 15) which was not capable to maintain safe residual space. From the above analysis it is found that, if superstructure fail and exceed residual space, it cannot prevent passengers from fatality or serious injury. Hence, to avoid superstructure failure when sustain this amount of total mass, another simulation was performed on the same bus increasing the strength of superstructure. The width and breadth of superstructure members' cross section were increased by 30 % and the thickness was increased by only 0.2 mm, then the bus was subjected to a maximum stress of 314 MPa during first impact. This showed that a small change in the strength of bus superstructure can contribute to a big reduction in maximum stress and deformation. This simulation showed less deformation of superstructure (position 4 in Fig. 15) and the superstructure was not protruding in the residual space. It proved that, total mass and strength of bus superstructure are very important factors to be considered during design. Therefore, to maintain safe residual space in bus during rollover accident, it is strongly recommended that the total mass of bus should be less keeping sufficient strength of superstructure. These results were also parallel to results obtained by previous study conducted by various institutions such as The National Safety Council, The Brookings Institution, and The Insurance Institute for Highway Safety, The General Motors Research Laboratories and The National Academy of Sciences. All of them agreed that reductions in the size and weight of passenger cars pose a safety threat.

V. CONCLUSION

The analyses of bus simulations provide very useful and fruitful results. It can be concluded that, the safe residual space for passengers inside bus during rollover impact is strongly dependent on some parameters. The strength of bus superstructure is the most important parameter to be considered in the design process. The total mass and the cross sectional dimensions of the members of superstructure should be optimized to get maximum ratio of strength to total mass. For the same superstructure strength, the simulation of bus with more total mass is not capable to preserve safe residual space during rollover process. Bus with increased total mass showed abnormal type of rollover motion, more deformation and structural vibration. Hence, the total mass should be as less as possible keeping sufficient strength of superstructure.

REFERENCES

- [1] Kecman, D., and Tidbury, G.H., "Optimisation of a Bus Superstructure from the Rollover Safety Point of View. Tenth International technical Conference on Experimental Safety Vehicles," Oxford, England, 1985.
- [2] White, D.M., P.S.V. "Rollover Stability," Tenth International Technical Conference on Experimental Safety Vehicles, Oxford, England, 1985.
- [3] Kumagai, K., Kabeshita, Y., Enomoto, H., and Shimojima, S., "An analysis Method for Rollover Strength of Bus Structures," Fourteenth International technical Conference on Enhanced Safety of Vehicles, Munich, Germany, 1994.
- [4] Kecman, D., and Dutton, A.J., "Development and Testing of the University Coach safety Seat," Fifteenth International Technical Conference on the Enhanced Safety of Vehicles, Melbourne, Australia, 1996.

- [5] Kecman, D., and Randell, N., "The Role of Calculation in the Development and Type Approval of Coach Structures for Rollover Safety," Fifteenth International Technical conference on the Enhanced Safety of Vehicles, Melbourn, Australia, 1996.
- [6] Botto, P., Caillieret, M.C., Patel, A., Got, C., and Tarriere, C., "Passenger Protection in Single and Double-Decker Coaches in Tipping Over," Thirteenth International Technical conference on Experimental Safety Vehicles, Paris, France, 1991.
- [7] Rasenack, W., Appel, H., Rau, H., and Rieta, C., "Best systems in Passenger Coaches," Fifteenth International Technical conference on the Enhanced Safety of Vehicles, Melbourne, Australia, 1996.
- [8] Marine, Micky C., Thomas, Terry M. and Wirth, Jeffrey L., "Characteristics of On-Road Rollovers," SAE International Congress & Exposition(Vehicle Dynamics & Simulation), March 1999, Document No.1999-01-0122, Detroit, MI, USA.
- [9] Roper, L. David, "Physics of Automobile Rollovers," 2001.
- [10] Ferrer, I., and Miguel, J.L., "Assessment of the Use of Seat Belts in Busses Based on Recent Road Traffic Accidents in Spain," Seventeenth International Technical Conference on the enhanced Safety of Vehicles, Amsterdam, the Netherlands, 2001.
- [11] Bish, Jack, Nash, Carl E., Paskin, Allan, H., "Terence and Friedman, Donald, an Evaluation of Production Vehicle Roof Strength," 2004 ASME International Mechanical Engineering Congress and Exposition, November 2004, IMECE2004-59885, California, USA.