

# Seismic Analysis of a S-Curved Viaduct using Stick and Finite Element Models

Sourabh Agrawal, and Ashok K. Jain

**Abstract**—Stick models are widely used in studying the behaviour of straight as well as skew bridges and viaducts subjected to earthquakes while carrying out preliminary studies. The application of such models to highly curved bridges continues to pose challenging problems. A viaduct proposed in the foothills of the Himalayas in Northern India is chosen for the study. It is having 8 simply supported spans @ 30 m c/c. It is doubly curved in horizontal plane with 20 m radius. It is inclined in vertical plane as well. The superstructure consists of a box section. Three models have been used: a conventional stick model, an improved stick model and a 3D finite element model. The improved stick model is employed by making use of body constraints in order to study its capabilities. The first 8 frequencies are about 9.71% away in the latter two models. Later the difference increases to 80% in 50<sup>th</sup> mode. The viaduct was subjected to all three components of the El Centro earthquake of May 1940. The numerical integration was carried out using the Hilber-Hughes-Taylor method as implemented in SAP2000. Axial forces and moments in the bridge piers as well as lateral displacements at the bearing levels are compared for the three models. The maximum difference in the axial forces and bending moments and displacements vary by 25% between the improved and finite element model. Whereas, the maximum difference in the axial forces, moments, and displacements in various sections vary by 35% between the improved stick model and equivalent straight stick model. The difference for torsional moment was as high as 75%. It is concluded that the stick model with body constraints to model the bearings and expansion joints is not desirable in very sharp S curved viaducts even for preliminary analysis. This model can be used only to determine first 10 frequency and mode shapes but not for member forces. A 3D finite element analysis must be carried out for meaningful results.

**Keywords**—Bearing, body constraint, box girder, curved viaduct, expansion joint, finite element, link element, seismic, stick model, time history analysis.

## I. INTRODUCTION

SEISMIC analysis of bridges and viaducts entails idealization. A common idealization for preliminary dynamic/seismic analysis is the use of a stick model. It consists of a beam element representing the superstructure of

the bridge and an array of translational and rotational springs to represent the bridge substructure. The stick model is quite simple and easy to model and gives reasonable results when the geometry of the bridge is also simple and major structural characteristics are modeled carefully. A number of investigators have developed various types of stick models for studying the response of skew bridges [1- 13]. Although these models are convenient and easy to use but some times they are unable to simulate some of the important mode shapes that are crucial in assessing the seismic behaviour of the bridge. The modeling of bearings and expansion joints as well as compatibility between the two adjoining spans needs to be carefully enforced. Most of the recent studies concentrate on non-linear time history response of bridges [6-13].

In this paper a S curved viaduct having unequal piers has been modeled using a conventional stick model, an improved stick model and a finite element model to assess their capability and performance. The cross-section of the deck is a box section. Only linear earthquake response was determined using time history analysis [14]. The purpose of this paper is to examine the capability of stick model using body constraints to simulate the boundary conditions at the bearings and expansion joints to predict the dynamic response of S curved viaducts.

## II. VIADUCT

A 8 span-30 m S curved viaduct is proposed to be built in the foothills of Himalaya in north India. The carriageway is two lanes – 7.65 m clear width. The longitudinal slope varies from zero to 2% and the heights of piers vary from 18.60 m to 27.20 m as shown in Fig. 1. The radius of the curved viaduct is 20 m. It is located in seismic zone IV of India. Each span is simply supported. The viaduct superstructure, pier cap, and pier have been represented as a stick model using frame elements; expansion joints and bearings have been modeled using the link (or spring) elements. The compatibility between the superstructure and bearings has been enforced through the use of body constraints. This was done to bring in the curvature effect. The same viaduct was again modeled using FE model. In order to study the effect of curvature, the entire bridge was straightened and reanalyzed. The entire modeling was done using SAP 2000[15].

Sourabh Agrawal is with the Department of Civil Engineering, Indian Institute of Technology Roorkee, 247667 India (e-mail: sourabhagraval@aol.in).

Ashok K. Jain is with the Department of Civil Engineering, Indian Institute of Technology Roorkee, 247667 India (phone: 91-1332285436; fax: 91-1332273560; e-mail: ashokjain\_iitr@yahoo.co.in).

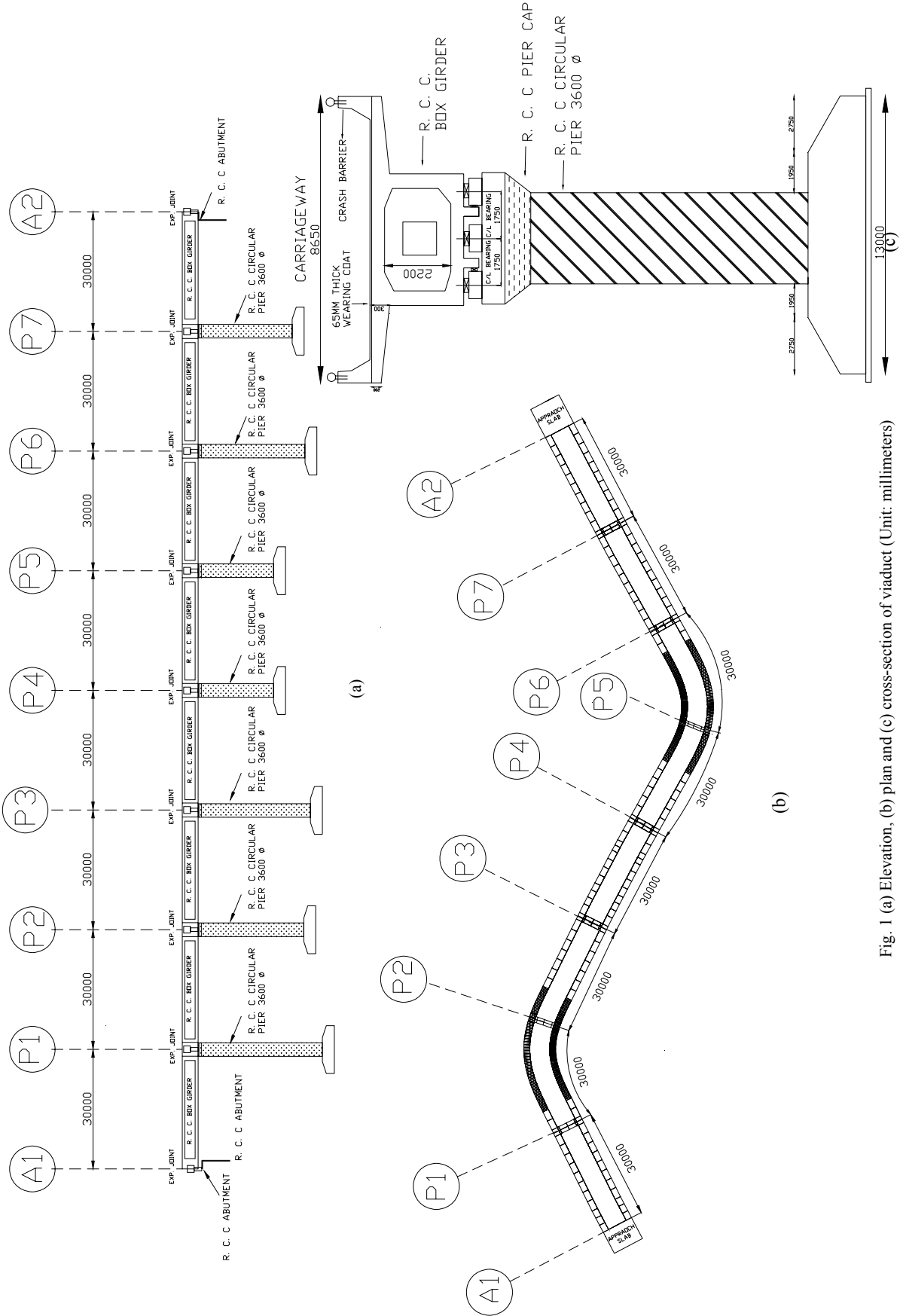

Fig. 1 (a) Elevation, (b) plan and (c) cross-section of viaduct (Unit: millimeters)

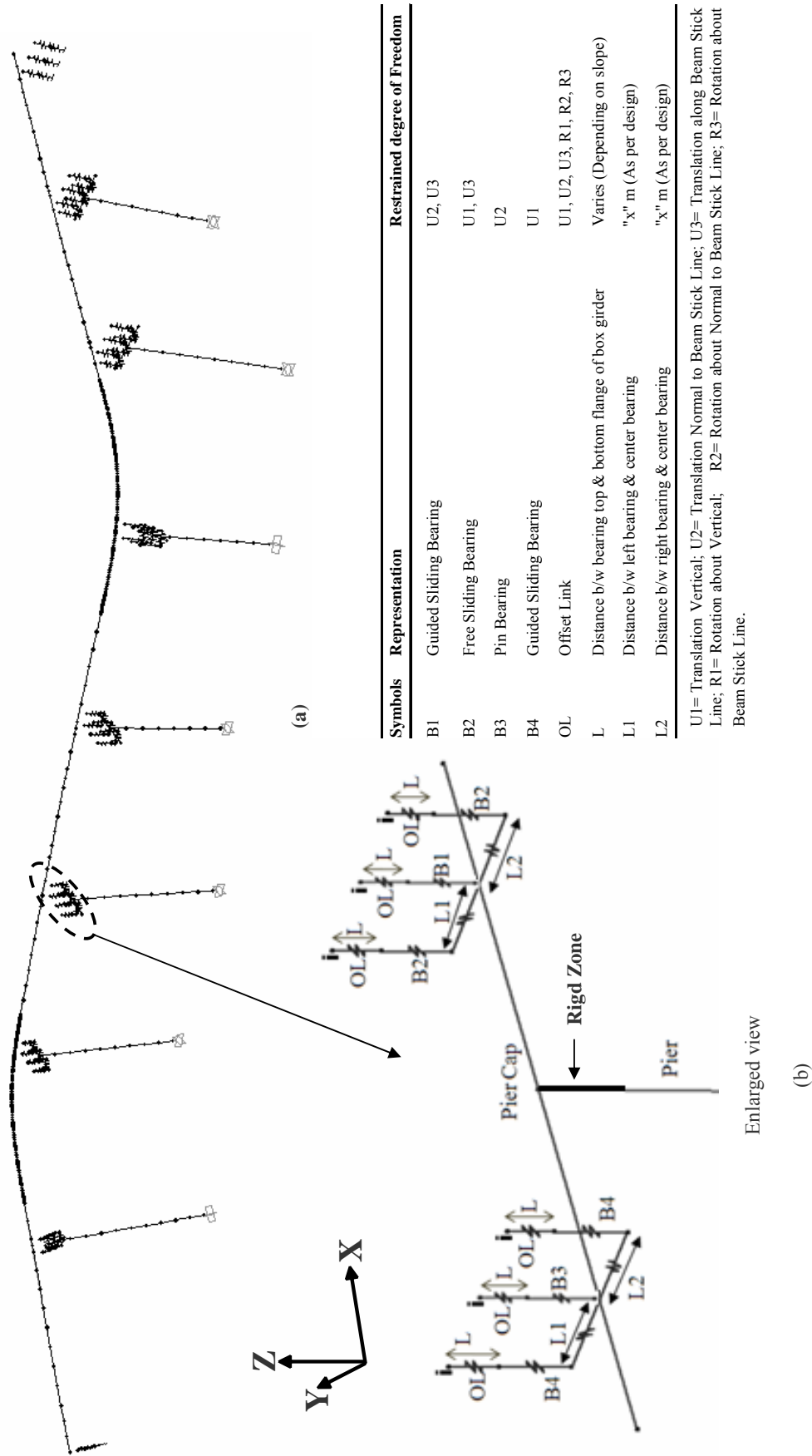

Fig. 2 (a) Improved stick model of viaduct, (b) Expansion joint model with specifications

III. ANALYTICAL MODELING

A. Improved Stick Model

i. Bridge Deck

The superstructure elements were modeled as linear –elastic frame elements located at the centroid of cross section, following the alignment of viaduct. The elevation (node height) of the superstructure frame elements was at the elevation of the superstructure centroid. ATC-32 [16,17] suggested that a minimum of five elements per span shall be used in a linear elastic model. However, superstructure was discretized in more than five elements to represent the curved geometry more accurately. At the location of expansion joints the superstructure was discretized in such a way to coincide with location of link (or spring) elements.

This discretization helps approximate the distributed (translational) mass of the bridge components with lumped mass at the nodes between segments generated automatically by SAP2000. This software calculates the translational mass of all longitudinal elements in the three global directions of the bridge (longitudinal, transverse and vertical) and assigns them as lumped mass at each node based on tributary lengths. The superstructure frame properties for the given box-girder cross section was defined in SAP2000 through a Section Designer (SD Section) given in Table I. Figure 2 shows the frame element in light lines whereas dark dots on it represent the discretization locations where the mass is lumped.

ii. Modeling of Bearings/Expansion Joint

The arrangement of bearings in real bridge is as shown in Fig. 3. Bearings are modeled using link/spring linear elements shown in Fig. 2(b).

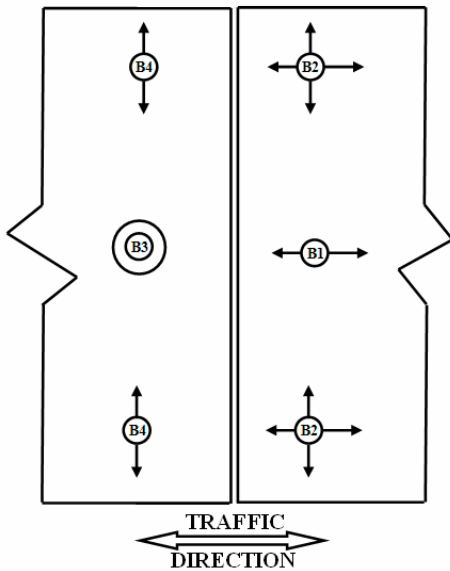

Fig. 3 Arrangement of bearings

iii. Piers and Pier caps

Bridge bents consist of pier and cap beams. In this procedure, the pier columns are modeled as a series of frame elements. ATC-32 suggested that a minimum of three elements per bent shall be used in a linear elastic model. However, piers are modeled by using seven to ten elements to represent large piers. Cap beams were modeled using different frame elements as it comprised of non-prismatic sections. It is discretized at locations where change in section and the location of bearings occur. At the junction of pier and pier cap rigid zone is modeled whose length is equal to half the depth of pier cap. The pier frame properties are summarized in Table I.

iv. Diaphragm

In stick model, it is not possible to model the diaphragm connecting inner corners. Typically, each diaphragm mass is calculated using tributary weights and lumped at their respective locations.

v. Abutment/Foundations

Fixed boundary conditions were specified at the base of piers. No attempt was made to model the soil medium underneath these piers. Similarly no attempt was made to model abutment backfill and retaining walls.

vi. Boundary Conditions

1. The node of the beam representing the box girder corresponding to the abutment end was fixed against translation about x, y and z directions on the left end abutment where as fixed against translation about y and z directions on the right end abutment and free against rotation about x, y and z axes about both abutments ends. The coordinate axes are shown in Fig. 2.

2. The nodes at the ends of the beam elements representing the base of the piers were fully fixed against translation and rotation in all directions.

3. The nodes representing the bearing elements were having boundary conditions as shown in table given in Fig. 2.

4. Translation in the x, y and z directions of the nodes (i) as shown in Fig. 4(a) at the top of the link element connecting the top of the bearings were constrained to translations and rotation about x, y and z axis of the nodes (j) on the beam centroidal axis directly above it. The constraint equations were

$$\begin{aligned}
 U_{xj} &= U_{xi} + R_{yi} (P_{zj} - P_{zi}) - R_{zi} (P_{yj} - P_{yi}) \\
 U_{yj} &= U_{yi} + R_{xi} (P_{xj} - P_{xi}) - R_{xi} (P_{zj} - P_{zi}) \\
 U_{zj} &= U_{zi} + R_{xi} (P_{yj} - P_{yi}) - R_{yi} (P_{xj} - P_{xi})
 \end{aligned}
 \tag{1}$$

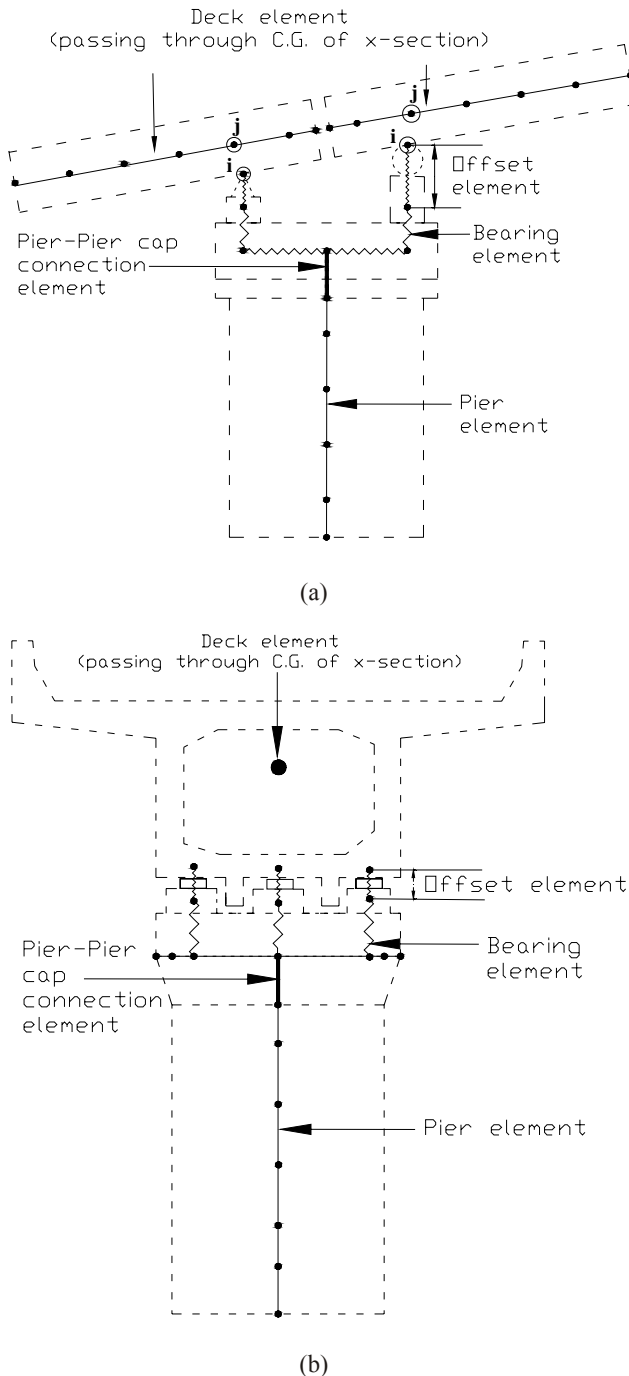

Fig. 4 Improved stick model expansion joint (a) longitudinal section (b) cross-section

5. Rotation in the x, y and z directions of the nodes(i) as shown in Fig. 4(a) at the top of the link element connecting the top of the bearings were constrained to similar rotations of the node(j) on the beam centroidal axis directly above it. The constraint equations were

$$\begin{aligned} R_{xi} &= R_{xj} \\ R_{yi} &= R_{yj} \\ R_{zi} &= R_{zj} \end{aligned} \quad (2)$$

**B. Conventional stick Model**

The primary difference between the improved and conventional stick model is in the modeling of expansion joint. In conventional stick model expansion joint as shown in Fig. 5, the connection between the deck and pier cap is modeled by using single link element with proper boundary conditions. The conventional model is shown in Fig. 6.

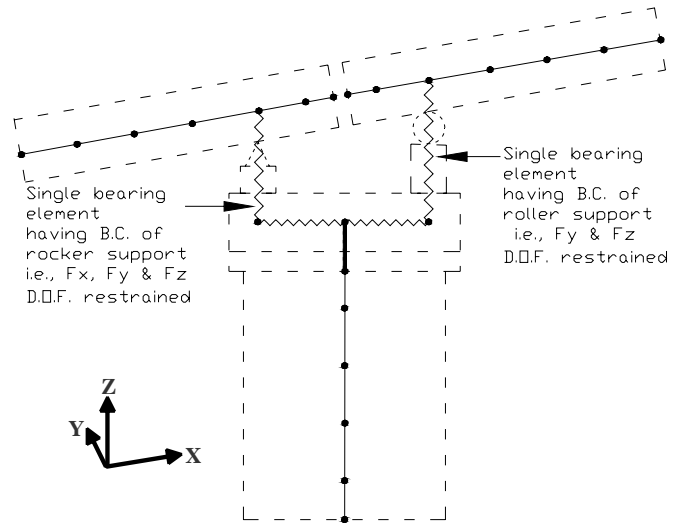

Fig. 5 Conventional stick model expansion joint

**C. Finite Element Model**

A detailed finite element model of the bridge was developed for comparison with the improved stick model. The superstructure was represented using 4-noded shell elements, pier cap and piers have been represented using line elements; expansion joints and bearings have been modeled using the link (or spring) elements. Two node frame elements were used to model the concrete piers. This model had 79008 DOF describing the bridge structure above the piers. Fixed boundary conditions were specified at the base of the piers. The compatibility between the superstructure and bearings are not required in the finite element model since it is enforced automatically. The mesh of this model is shown in Fig. 7. The material properties used for the analysis were those of M 35 grade reinforced concrete with a modulus of elasticity of E= 31,500 MPa and a mass density of  $\rho = 2,500 \text{ kg/m}^3$ .

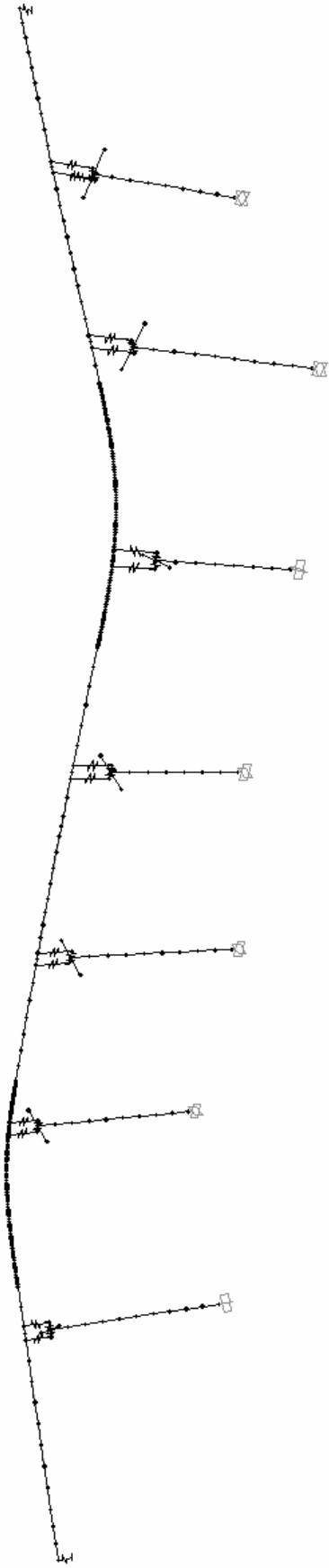

Fig. 6 Conventional stick model

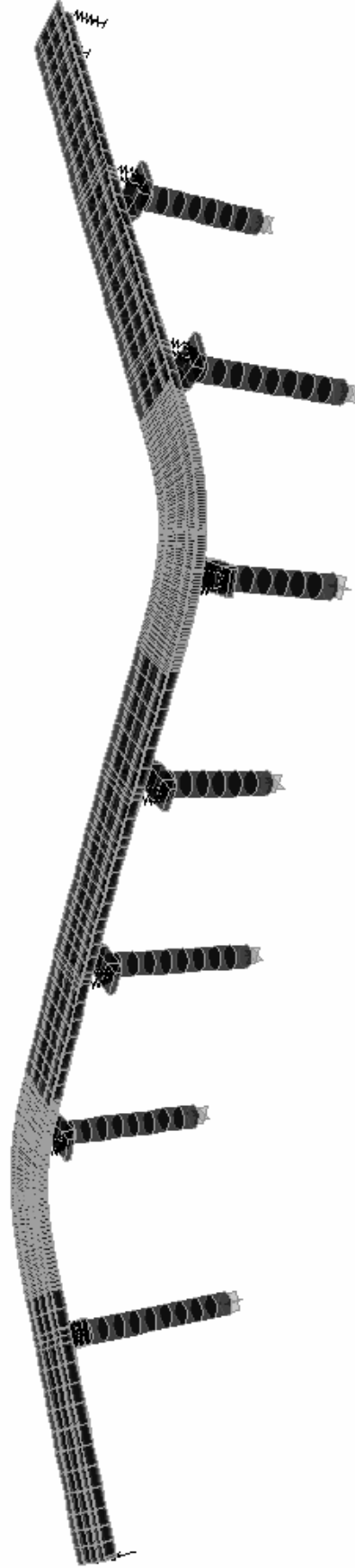

Fig. 7 Finite element model

TABLE I  
INPUT VALUES FOR STICK MODEL OF VIADUCT

Parameter	Description	Deck Section Properties	Column Section Properties
A	Area of the section	4.9975 m <sup>2</sup>	10.1788 m <sup>2</sup>
J	Torsional constant	11.4172 m <sup>4</sup>	16.4896 m <sup>4</sup>
I33	Moment of inertia about the 3-axis	5.5776 m <sup>4</sup>	8.2448 m <sup>4</sup>
I22	Moment of inertia about the 2-axis	27.225 m <sup>4</sup>	8.2248 m <sup>4</sup>
I23	Moment of inertia	0 (Due to symmetry)	0 (Due to symmetry)
As2	Shear area for shear parallel to the 2-axis	3.2454 m <sup>2</sup>	9.1609 m <sup>2</sup>
As3	Shear area for shear parallel to the 3-axis	1.6694m <sup>2</sup>	9.1609 m <sup>2</sup>
S33 (+face)	Section modulus about the 3-axis at extreme fibre of the section in the +ve 2-axis direction	5.2713 m <sup>3</sup>	4.5804 m <sup>3</sup>
S22 (+face)	Section modulus about the 2-axis at extreme fibre of the section in the +ve 3-axis direction	3.3971 m <sup>3</sup>	4.5804 m <sup>3</sup>
S33 (-face)	Section modulus about the 3-axis at extreme fibre of the section in the -ve 2-axis direction	6.3017 m <sup>3</sup>	4.5804 m <sup>3</sup>
S22 (-face)	Section modulus about the 2-axis at extreme fibre of the section in the -ve 3-axis direction	6.3017 m <sup>3</sup>	4.5804
Z33	Plastic modulus about the 3-axis of the section	5.1881 m <sup>3</sup>	7.776 m <sup>3</sup>
Z22	Plastic modulus about the 2-axis of the section	10.4553 m <sup>3</sup>	7.776 m <sup>3</sup>
r33	Radius of gyration about the 3-axis	1.0564 m	0.9 m
r22	Radius of gyration about the 2-axis	2.3353 m	0.9 m

### III. ANALYSIS AND RESULTS

#### A. Natural Vibration Frequencies

To further investigate the feasibility of applying improved stick model to study the behavior of curved simply supported bridges, FE model was analyzed. The first few natural vibration frequencies and mode shapes computed for the two bridge models in Fig. 8a- 8c. The undeformed geometry is shown in light lines and the deformed geometry is shown in dark lines. The results indicate that the first few natural frequencies and mode shapes compare quite well for the two models.

Since the number of modes recommended for use in seismic response calculations should correspond to at least 90% of the participating mass of the system model, additional frequencies calculated for the two models are compared in Fig 9. Lines are drawn between data points to show trends. It can be seen that

while the proposed model gives good results for the lower modes, the accuracy deteriorates with higher modes. Table II compares the frequencies identified using the conventional and improved stick models with those calculated using the 3D finite element model. However for higher frequency modes the errors in the frequencies become significantly larger. The boundary conditions specified in the stick model were intended to simulate those in the prototype. The primary source of discrepancy between the stick model and the detailed shell element model is thought to be the inability to accurately model the three-dimensional boundary conditions with the stick model and to accurately model the influence of the cross beams. The connections of the box girders to the piers provide partial restraint of warping, which cannot be accurately modeled when only a single frame element is used to simulate the bridge cross section. However, this inaccuracy in higher mode predictions should be viewed in the context that the stick model is simply a means to obtain preliminary solutions. The close correlation between the first few dominating modes obtained using the complex finite-element model and the improved stick model justifies the use of the latter for determining natural frequency and mode shapes.

TABLE II  
COMPARISON OF CONVENTIONAL STICK MODEL, IMPROVED STICK MODEL WITH FE MODEL RESULTS

Mode	Frequency (Hz)				
	Conventional Stick Model (Hz)	Improved Stick Model (Hz)	FE Model (Hz)	% difference b/w FE model and Improved stick model	% difference b/w FE model and Conventional stick model
1	1.01	1.06	1.01	4.72	0.00
2	0.9	1.11	1.02	8.11	13.33
3	0.85	1.18	1.10	6.78	29.41
4	0.82	1.22	1.11	9.02	35.37
5	0.69	1.24	1.18	4.84	71.01
6	0.66	1.32	1.21	8.33	83.33
7	0.66	1.52	1.27	16.45	92.42
8	0.59	1.70	1.37	19.41	132.20
<b>Average % difference</b>				9.71	57.14

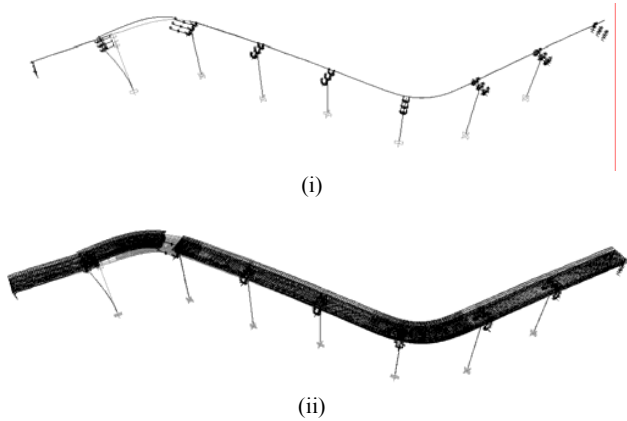

Fig. 8(a) Mode shape comparison (first longitudinal translation mode): (i) improved stick model (ii) finite-element model.

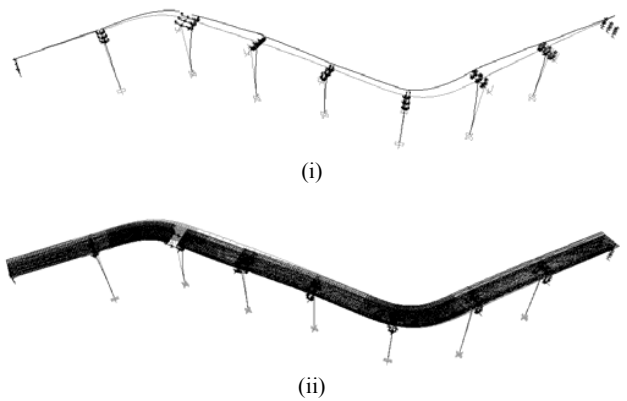

Fig. 8(b) Mode shape comparison (first transverse translation mode): (i) improved stick model (ii) finite-element model.

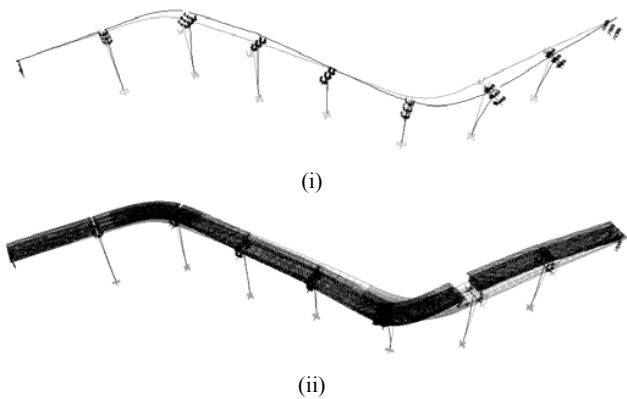

Fig. 8(c) Mode shape comparison (first torsion mode): (i) improved stick model (ii) finite-element model.

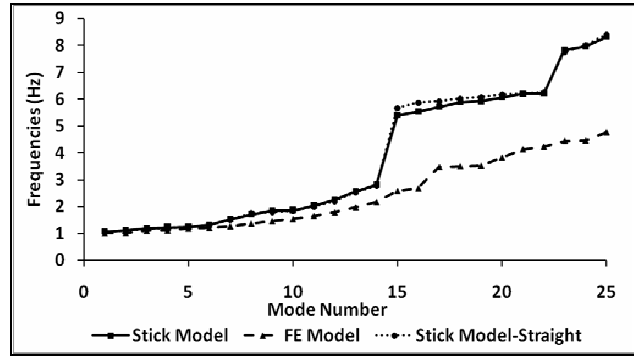

Fig. 9 Comparison of natural frequencies

*B. Time History Analysis*

Time history analysis is performed for the three components of the El Centro earthquake of May 1940. Two different models i.e., stick model and finite element model, were employed in the study. The duration of the ground motion was taken as 20 seconds with integration step size equal to 0.005 seconds. 5% damping was assumed proportional to both mass and stiffness. The step by step numerical integration was carried out using Hilber-Hughes-Taylor method. The earthquake responses reported herein include the displacement of the pier top, the axial forces, shear forces, and torsion in piers.

Fig. 10-15 show a comparison of the column axial forces, shear forces moments and torsion calculated using the two models. Again lines are drawn between data points to facilitate comparison. The figures indicate that the beam-stick model tend to overestimate forces and moments. Nevertheless, this model provides a rather good indication of how the internal forces and moments are distributed among the 7 supporting columns.

Figs. 16 and 17 show the longitudinal (X) and transverse displacement (Y) at the top of piers computed using the finite element and stick models. The numbering of piers for two models was given in Fig. 1.



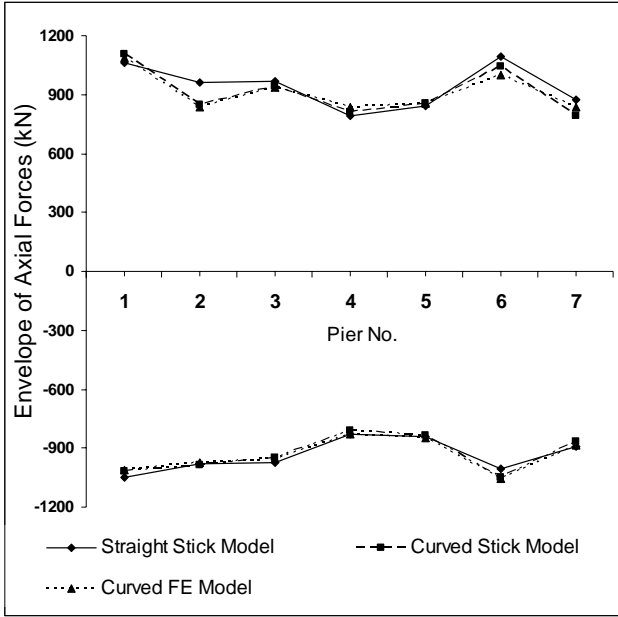

Fig. 10 Comparison of column axial forces at bottom

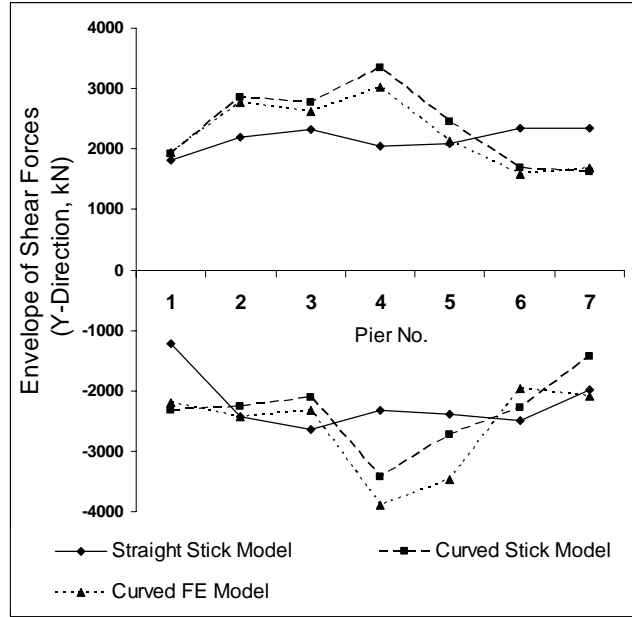

Fig. 12 Comparison of column shear forces in transverse direction at bottom

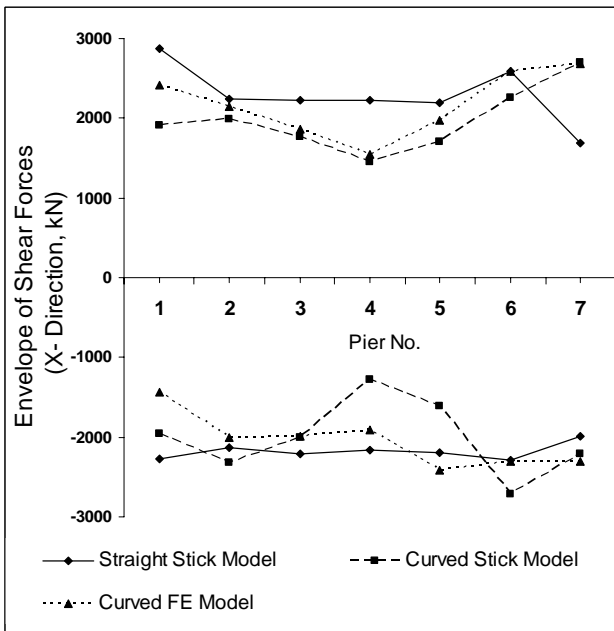

Fig. 11 Comparison of column shear forces in longitudinal direction at bottom

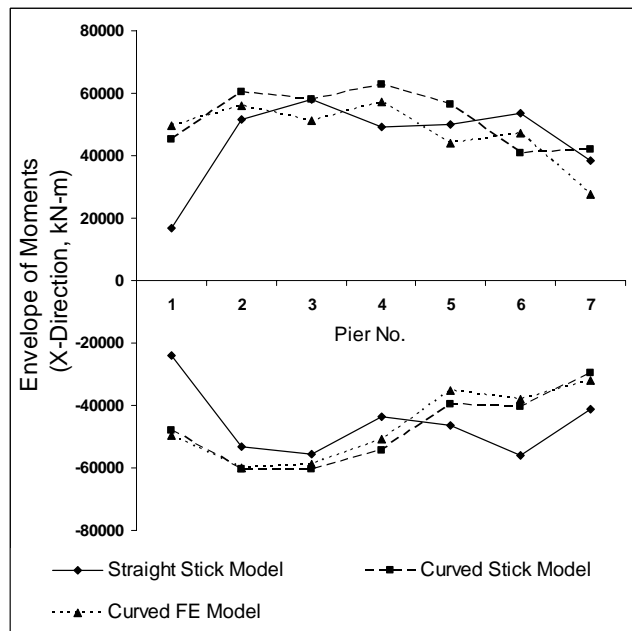

Fig. 13 Comparison of column moments in longitudinal direction at bottom

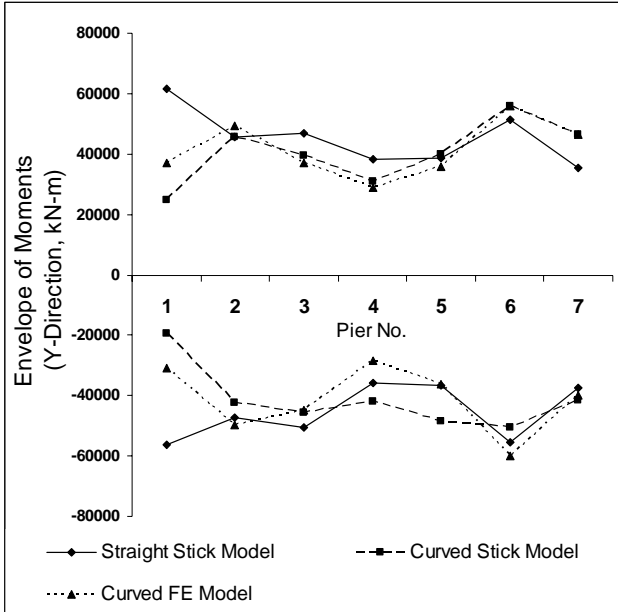

Fig. 14 Comparison of column moments in transverse direction at bottom

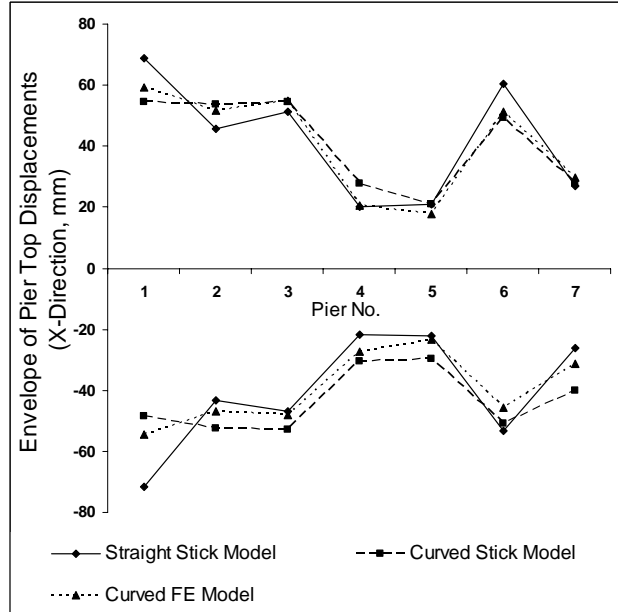

Fig. 16 Comparison of pier top X-displacement

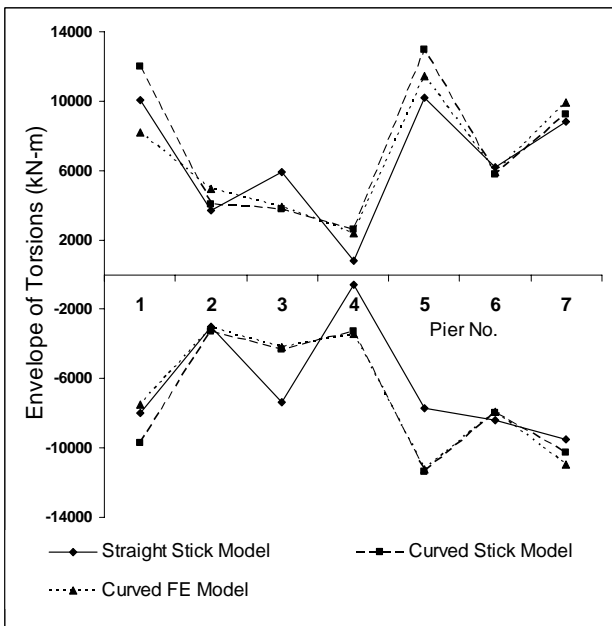

Fig. 15 Comparison of column torsion at bottom

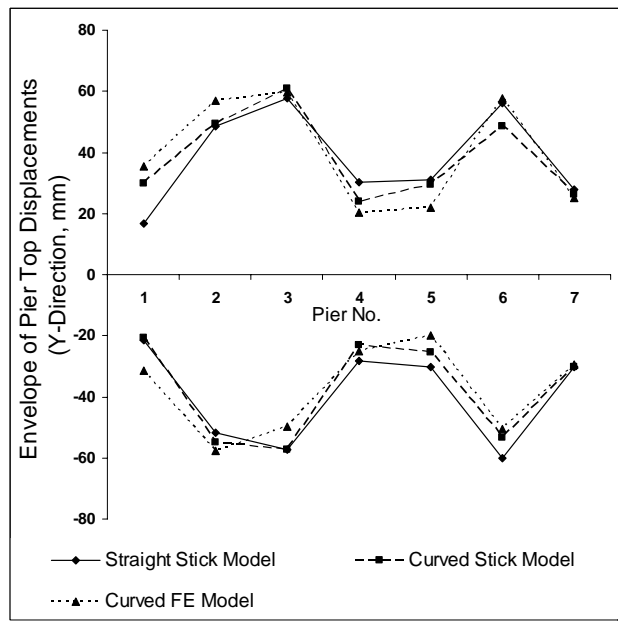

Fig. 17 Comparison of pier top X-displacement

## IV. CONCLUSION

Based on the results presented in this paper, the following significant conclusions may be drawn:

1. Average difference between the first eight frequencies of conventional Stick Model and the finite element model is 57.14%, as conventional stick model fail to capture the coupling between translational and transverse modes.
2. Average difference between the first eight frequency of improved stick model and the finite element model is 9.71% and shows good similarity between initial modes shapes.
3. The average difference between the results of improved stick model in a straight bridge and a curved bridge in various piers in axial force, shear force and bending moments along longitudinal and transverse directions are about 30%. However, the difference in torsional moments is 77%.
4. The average difference between the results of improved stick model and finite element model in a curved bridge in various piers in axial force, shear force and bending moments along longitudinal and transverse directions are about 25% including torsion.

Thus it can be concluded that the improved model with body constraints may be used for determining the first 10 modes with reasonable accuracy. However, the difference in member forces especially torsional moments is quite appreciable. The effect of curvature is to introduce significant torsion in superstructure, pier cap and piers /columns.

## REFERENCES

- [1] Farrar C. R., and Duffey, T. A. (1998). "Bridge modal properties using simplified finite element analysis." J. Bridge Engg.3 (1) ASCE, N.Y., 38-46.
- [2] Meng, J. Y., and Lui, E. M. (2002). "Refined stick model for dynamic analysis of skew bridges." J. Bridge Engg. 7(3) ASCE, N.Y., 184-194.
- [3] Abeysinghe, R.S., Gavaise, E., Rosignoli, M. and Tzaveas, T.(2002). "Pushover analysis of inelastic seismic behavior of Greveniotikos bridge." J. Bridge Engg. 7(2), 115-126.
- [4] Samaan, M., Kennedy, J.B. and Sennah, K.(2007) "Dynamic analysis of curved continuous multiple-box girder bridges." J. Bridge Engg. 12(2) ASCE, N.Y., 184-193.
- [5] Wang, T.L., Huang, D. and Shahawy, M. (1996). "Dynamic behavior of continuous and cantilever thin-walled box girder bridges." J. Bridge Engg. 1(2), 67-75.
- [6] Brudette, N.J. and Elnashi, A.M. (2008). "Effect of asynchronous earthquake motion on complex bridges II: Results and implications on assessment." J. Bridge Engg. 13(2) ASCE, N.Y., 166-172.
- [7] Brudette, N.J., Elnashi, A.S., Lupoi, A. and Sextos, A.G.(2008). "Effect of asynchronous earthquake motion on complex bridges I: Methodology and input motion." J. Bridge Engg. 13(2) ASCE, N.Y., 158-165.
- [8] DesRoches, R., Choi, E., Leon, R.T., Dyke, S.J. and Aschheim, M.(2004) "Seismic response of multiple span steel bridges in central and southeastern United States. I:As built." J. Bridge Engg. 9(5) ASCE, N.Y., 464-472.
- [9] Mwafy, A., Elnashai, A. and Yen, W. H. (2007). "Implications of design assumptions on capacity estimates and demand predictions of multispan curved bridges." J. Bridge Engg. 12(6) ASCE, N.Y., 710-726.
- [10] Nielson, B. G., and DesRoches, R. (2007). "Seismic performance assessment of simply supported and continuous multispan concrete girder highway bridges." J. Bridge Engg. 12(5) ASCE, N.Y., 611-620.
- [11] Rashidi, S. and Saadeghvaziri, M. A.(1997). "Seismic modeling of multi-span simply-supported bridges using ADINA." Computer & Structures, 64(5/6), 1025-1039.
- [12] Saadeghvaziri, M. A. and Yazdani-Motlagh, A. R. (2008). "Seismic behavior and capacity/demand analyses of three multi-span simply supported bridges." Engineering Structures, 30, 54-66.
- [13] Dieleli, M. (2002). "Seismic design of lifeline bridge using hybrid seismic isolation." J. Bridge Engg. 7(2) ASCE, N.Y., 94-103.
- [14] IRC6, 2000, *Standard specifications and code of practice for road bridges, Section: II Load and stresses*, Indian Road Congress, New Delhi.
- [15] SAP2000 (2008), *Integrated structural analysis and design software*. Version 12, Computers and Structures, Berkeley, Calif.
- [16] ATC-32 (1996a), *Improved Seismic Design Criteria for California Bridges: Provisional Recommendations*, Applied Technology Council, Redwood City, California.
- [17] ATC-32-1 (1996b), *Improved Seismic Design Criteria for California Bridges: Resource Document*, Applied Technology Council, Redwood City, California.



**Sourabh Agarwal** (Mathura, March, 1984), B.Tech. (Hons.) 2007, M. Tech. (I.I.T. Roorkee). Graduate Student



**Ashok K. Jain** (Roorkee, Oct. 1950) B.E. (Hons.) 1972, M.E. (Hons.) 1974, PhD. (Michigan, USA) 1978. Currently working as Professor of Civil Engineering at Indian Institute of Technology Roorkee. His main areas of interest include reinforced concrete, multistoried buildings, towers, bridges and earthquake resistant design of structures.

He has been a post doctoral research fellow at the University of Michigan, and visiting Scholar / Professor at the University of Illinois, Chicago, and McGill University, Montreal, and Nepal Engineering College, Kathmandu. He has authored four text books on structures and computers, and published over 120 papers in reputed national and international journals and conferences. He has over 30 years of experience in teaching, research and consultancy.

Dr. Jain is a Fellow of the Institution of Engineers and Indian Association of Structural Engineers; Life member of Indian Concrete Institute, and Indian Society of Earthquake Technology; and Honorary Fellow, Indian Institute of Quality Management.