

A Fast Handover Scheme for Proxy Mobile IPv6 using IEEE 802.21 Media Independent Handover

Pyung-Soo Kim and Jeong Hun Choi

Abstract—In this paper, to resolve the problem of existing schemes, an alternative fast handover Proxy Mobile IPv6 (PMIPv6) scheme using the IEEE 802.21 Media Independent Handover (MIH) function is proposed for heterogeneous wireless networks. The proposed scheme comes to support fast handover for the mobile node (MN) irrespective of the presence or absence of MIH functionality as well as L3 mobility functionality, whereas the MN in existing schemes has to implement MIH functionality. That is, the proposed scheme does not require the MN to be involved in MIH related signaling required for handover procedure. The base station (BS) with MIH functionality performs handover on behalf of the MN. Therefore, the proposed scheme can reduce burden and power consumption of MNs with limited resource and battery power since MNs are not required to be involved for the handover procedure. In addition, the proposed scheme can reduce considerably traffic overhead over wireless links between MN and BS since signaling messages are reduced.

Keywords—Fast handover, PMIPv6, MIH.

I. INTRODUCTION

AS shown in [1]-[5], the integration of WWAN (Wireless Wide Area Network), WMAN (Wireless Metropolitan Area Network), WLAN (Wireless Local Area Network), WPAN (Wireless Personal Area Network) will be linked with many technical challenges including IP mobility, vertical handover, security, common authentication, unified accounting/billing, consistent QoS and service provisioning, etc. Among them, the IP mobility for vertical handover in heterogeneous wireless access networks is considered in this paper.

As an IP mobility and handover solution for heterogeneous wireless networks, the Proxy Mobile IPv6 (PMIPv6) can be adopted[6]. The PMIPv6 protocol does not require the mobile node (MN) to be involved in the L3 signaling required for handover procedure. The mobility access gateway (MAG) performs the L3 signaling required for handover procedure on behalf of the MN. However, since the MN moves between different two MAGs in PMIPv6, the handover latency cannot be avoided. Therefore, in order to reduce handover latency, various fast handover PMIPv6 schemes are being researched recently on early stage[7]-[13]. These existing schemes are classified by a couple of approaches. The first approach is based on the exchange of L3 signaling messages[7]-[9]. This approach can be implemented by the basic PMIPv6 protocol without additive protocols and thus ease to implement and cost-effective. The second approach is based on the exchange of IEEE 802.21 Media Independent Handover (MIH) related signaling messages as well as L3 mobility

signaling messages[10]-[13]. In this paper, the latter approach is considered for heterogeneous wireless networks. Although the latter approach can reduce the handover latency through the interaction between cross layers, the MN has to implement MIH functionality. However, this can be contradictable with the original objective of the PMIPv6[6] that does not require the MN to be involved in the L3 signaling required for handover procedure. In addition, this can be somewhat burdensome and power consumptive for MNs with limited resource and battery power. Moreover, there can be the number of MIH related signaling messages for handover procedure, which can cause considerable traffic overhead over wireless links.

Therefore, to resolve the problem of existing schemes in [10]-[13], an alternative fast handover PMIPv6 scheme using the IEEE 802.21 MIH function is proposed for heterogeneous wireless networks. The proposed scheme comes to support fast handover for the MN irrespective of the presence or absence of MIH functionality as well as L3 mobility functionality, whereas the MN in existing schemes has to implement MIH functionality. That is, the proposed scheme does not require the MN to be involved in MIH related signaling required for handover procedure. The base station (BS) with MIH functionality performs handover procedure on behalf of the MN. Therefore, the proposed scheme can reduce burden and power consumption of MNs with limited resource and battery power since MNs are not required to be involved for the handover procedure. In addition, the proposed scheme can reduce considerably traffic overhead over wireless links between MN and BS since signaling messages are reduced.

II. TECHNICAL BACKGROUNDS

A. Overview of Proxy Mobile IPv6

Mobile IPv6 (MIPv6) has been designed to be an integral part of the IPv6 stack in a host. However, there exist IPv6 stacks today that do not have MIPv6 functionality and there would likely be IPv6 stacks without MIPv6 client functionality in the future as well. It is desirable to support IP mobility for all hosts irrespective of the presence or absence of MIPv6 functionality in the IPv6 stack. Therefore, in recent, Proxy Mobile IPv6 (PMIPv6) is being standardized in Internet Engineer Task Force (IETF)[6]. This protocol to supporting mobility does not require the mobile node (MN) to be involved in the signaling required for mobility management. The mobility access gateway (MAG) in the network performs the signaling and does the mobility management on behalf of the MN. In the future, PMIPv6 can be the L3 handover solution for wireless

Authors are with the Dept. of Electronics Engineering, Korea Polytechnic University, Shiheung-City, Kyunggi-Do, KOREA.

Corresponding Author : Pyung-Soo Kim (poongdou@gmail.com)

access networks. However, since the MN moves between different two MAGs in PMIPv6, the handover latency cannot be avoided. Therefore, the need to communicate efficiently on the move and to minimize the packet loss caused by a handover is becoming increasingly important because the handover latency is unacceptable for real-time IP services and throughput sensitive applications.

B. Overview of IEEE 802.21 MIH Function

To provide general solutions for the vertical handover in heterogeneous access networks, the IEEE 802.21 standards group is currently discussing the media independent handover (MIH) function [2]. The major purpose of MIH function is to provide abstracted services to upper layers by means of a unified interface and thus to enhance users' experience of mobile devices by supporting handover between heterogeneous networks. These services provided by MIH function help the upper layers in maintaining service continuity, service adaptation to varying quality of service, battery life conservation, and network discovery and link selection. In a system containing heterogeneous network interfaces of 802 types and cellular 3GPP, 3GPP2 types, the MIH function can help the upper layers to implement effective procedures to couple services across heterogeneous network interfaces. Upper layers may utilize services provided by the MIH function across different entities to query and reserve resource required for a handover operation between heterogeneous access networks. Therefore, the MIH function can be very useful facilities for vertical handovers in heterogeneous wireless networks.

III. PROPOSED SCHEME

As shown in Figure 1, in the proposed scheme, a couple of new entities exists in access networks. Firstly, there is an MIH capable wireless base station (BS), which is called the MIH-BS. The MIH-BS manages the MIH related signaling on behalf of the MN that is attached to its L2. Secondly, there is an access router that plays a role of point of service (PoS) as well as MAG. The MAG manages the L3 mobility related signaling on behalf of the MN that is attached to its L3. The PoS manages the MIH related signaling.

A. Operation Procedure

1) Acquisition of Information on Adjacent Networks:

When the MN in the serving network senses the signal strength of the serving MIH-BS is becoming too weak, the MN decides the L2 handover. Then, the MN's L2 produces a handover trigger and sends it to the serving MIH-BS. Then, the serving MIH-BS sends *MIH_Link_Going_Down Indication* to the serving PoS located in the serving access router. The serving PoS queries the MIIS(Media Independent Information Service) Server to retrieve information about available adjacent networks to which the attached MN may handover. This retrieval is done through exchanging *MIH_Get_Information Request* and *MIH_Get_Information Response*.

2) *Determination of Handover Target:* The serving PoS triggers a network-initiated handover by sending the *MIH_Net_HO_Candidate_Query Request* message to the serving MIH-BS. The serving MIH-BS responds through the *MIH_Net_HO_Candidate_Query Response* message. This message contains serving MIH-BS's acknowledgement about the handover and its preferred link and PoS lists. The serving PoS sends the *MIH_N2N_HO_Query_Resource Request* messages to different candidate PoSs (can be more than one) to query the availability of resource to provide QoS at candidate networks. The candidate PoS responds by sending the *MIH_N2N_HO_Query_Resource Response* message to the Serving PoS. The serving PoS determines the target network and the new MAG (NMAG) for the handover based on the resource availability information of candidate networks through the received *MIH_N2N_HO_Query_Resource Response* message.

3) *Handover Preparation:* The serving PoS requests handover commitment to the target MIH-BS in the target network by sending the *MIH_Net_HO_Commit Request* message to the serving MIH-BS. The serving PoS also notifies the target PoS of the fact the MN is about to move to the network and connect to the NMAG through the *MIH_N2N_HO_Commit Request* message. The serving MIH-BS and target PoS reply the result of the handover commitment by sending *MIH_Net_HO_Commit Response* and *MIH_N2N_HO_Commit Response*, respectively. Upon receiving the *MIH_N2N_HO_Commit Request* message, the NMAG in the target network queries the incoming MN's profile information to a policy store such as AAA server. As a result, the NMAG obtains profile information for PMIPv6 processes corresponding to the MN.

4) *Handover Execution:* Once the MN establishes L2 connection to the target MIH-BS in the target network, the NMAG detects the MN's attachment and then sends Router Advertisement (RA) message to the MN. The RA message is constructed with the queried MN's profile information. It can be solicited by Router Solicitation (RS) message from the MN and periodically transmitted. MN configures IP addresses on its interface, currently used to connect to the NMAG, based on the received RA message. The NMAG in the target network registers the current MN's location to LMA by sending Proxy Binding Update (PBU) message. After reception of PBU, the LMA updates the lifetime for the MN's entry in binding cache table, and replies with Proxy Binding Acknowledgement (PBA) message, then starts transmission of the buffered data through the tunnel between LMA and NMAG. Thus, the PMIPv6 procedures are completed and then MN receives packets through both NMAG and LMA.

5) *Handover Completion:* After the PMIPv6 procedure, the target PoS may send the *MIH_MN_HO_Complete Request* message to the serving PoS. The target PoS may send the *MIH_N2N_HO_Complete Response* message to the serving PoS.

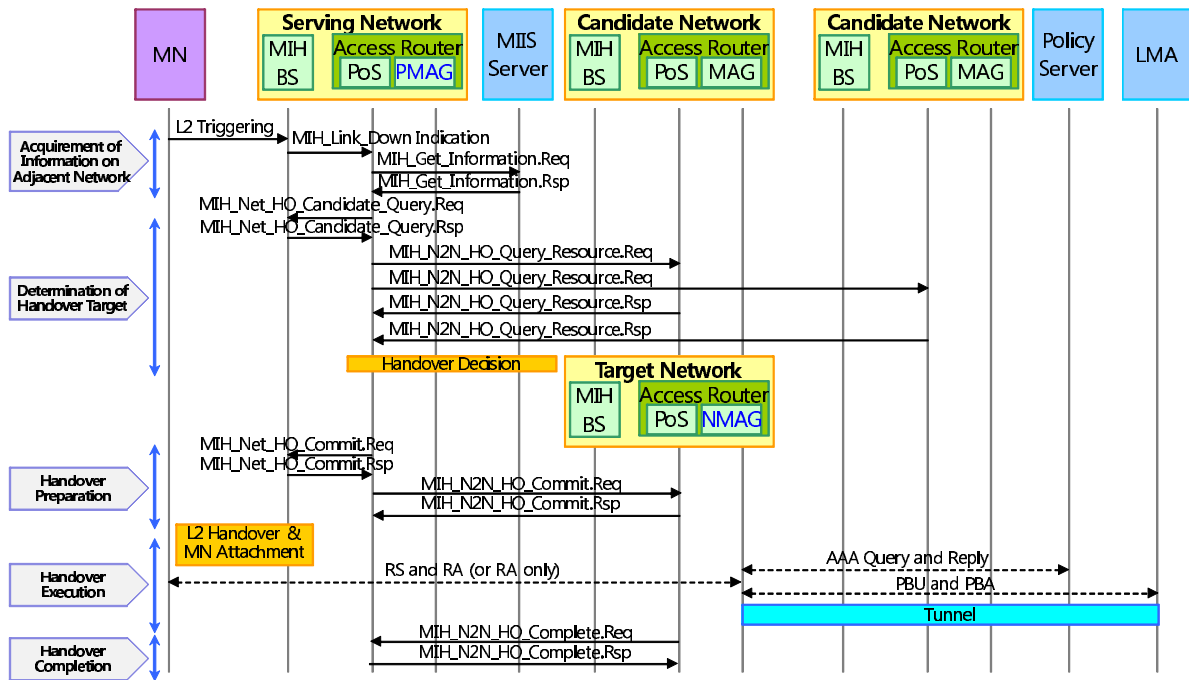

Fig. 1. Operation of proposed fast handover PMIPv6 scheme using IEEE 802.21 MIH function

B. Advantages

The proposed scheme comes to support fast handover for the MN irrespective of the presence or absence of MIH functionality as well as L3 mobility functionality, whereas the MN in existing schemes has to implement MIH functionality. That is, the proposed scheme does not require the MN to be involved in MIH related signaling required for handover procedure. The MIH-BS performs handover on behalf of the MN. Therefore, the proposed scheme can reduce burden and power consumption of MNs with limited resource and battery power since MNs are not required to be involved for the handover procedure. In addition, the proposed scheme can reduce considerably traffic overhead over wireless links between MN and BS since signaling messages are reduced.

ACKNOWLEDGMENT

This work was supported by the IT R&D program of MKE/KEIT [10035245: Study on Architecture of Future Internet to Support Mobile Environments and Network Diversity].

IV. CONCLUSION

This paper has proposed an alternative fast handover PMIPv6 scheme using the IEEE 802.21 MIH function is proposed for heterogeneous wireless networks to resolve the problem of existing schemes. The proposed scheme comes to support fast handover for the MN irrespective of the presence or absence of MIH functionality as well as L3 mobility functionality, whereas the MN in existing schemes

has to implement MIH functionality. That is, the proposed scheme does not require the MN to be involved in MIH related signaling required for handover procedure. The MIH-BS performs handover on behalf of the MN. Therefore, the proposed scheme can reduce burden and power consumption of MNs with limited resource and battery power since MNs are not required to be involved for the handover procedure. In addition, the proposed scheme can reduce considerably traffic overhead over wireless links between MN and BS since signaling messages are reduced.

REFERENCES

- [1] W. Wu, N. Banerjee, K. Basu, and S.K. Das, "SIP based vertical handoff between WWANs and WLANs," *IEEE Wireless Communications*, vol. 12, no. 3, pp. 66–72, 2005.
- [2] IEEE802.21/D09.00, "Draft standard for local and metropolitan area networks : Media independent handover services," in *IEEE Standards*, Feb 2008.
- [3] M. Kassar, B. Kervella, and G. Pujolle, "An overview of vertical handover decision strategies in heterogeneous wireless networks," *Computer Communications*, vol. 31, no. 10, pp. 2607–2620, 2008.
- [4] P. S. Kim and S. K. Lee, "HMIPv6 based fast vertical handover mechanism using media independent handover function," *Journal of Korean Information and Communication Society*, vol. 34, no. 1, pp. 67–73, 2009.
- [5] P. S. Kim, "A new reactive FMIPv6 mechanism for minimizing packet loss," *IEICE Trans. Commun.*, vol. E93-B, no. 1, pp. 166–169, 2010.
- [6] S. Gundavelli, K. Leung, V. Devarapalli, K. Chowdhury, and B. Patil, *Proxy Mobile IPv6*, IETF RFC 5213, August 2008.
- [7] P. S. Kim, S. E. Kim, J. Jin, and S. C. Lee, "Proactive correspondent registration for Proxy Mobile IPv6 route optimization," *International Journal of Computer Science and Network Security*, vol. 7, no. 11, pp. 149–154, 2007.

- [8] X. Fu and J. Lei, "Evaluating the benefits of introducing PMIPv6 for localized mobility management," in *Proc. of Wireless Communications and Mobile Computing Conference*, 2008, pp. 74–80.
- [9] H. Yokota, K. Chowdhury, B. Patil, and F. Xia, *Fast Handovers for PMIPv6*, IETF Draft : draft-yokota-mipshop-pfmipv6-03.txt, July 2008.
- [10] L. A. Magagula and H. A. Chan, "IEEE 802.21-Assisted cross-layer design and PMIPv6 mobility management framework for next generation wireless networks," in *Proc. of the 2008 IEEE International Conference on Wireless & Mobile Computing, Networking & Communication*, 2008, pp. 159–164.
- [11] L. A. Magagula and H. A. Chan, "IEEE 802.21 Optimized handover delay for Proxy Mobile IPv6," in *Proc. of the 2008 IEEE Military Communications Conference (MILCOM2008)*, 2008, pp. 1–7.
- [12] I. Kim, Y. C. Jung, and Y. Kim, "Low latency proactive handover scheme for Proxy MIPv6 with MIH," *Lecture Notes In Computer Science*, vol. 5297, pp. 344 – 353, 2008.
- [13] S. Jeon, N. Kang, and Y. Kim, "Enhanced predictive handover for fast Proxy Mobile IPv6," *IEICE Trans. Commun.*, vol. E92-B, no. 11, pp. 3504–3507, 2009.