

Transmission Pricing based on Voltage Angle Decomposition

M. Oloomi-Buygi, and M. Reza Salehizadeh

Abstract—In this paper a new approach for transmission pricing is presented. The main idea is voltage angle allocation, i.e. determining the contribution of each contract on the voltage angle of each bus. DC power flow is used to compute a primary solution for angle decomposition. To consider the impacts of system non-linearity on angle decomposition, the primary solution is corrected in different iterations of decoupled Newton-Raphson power flow. Then, the contribution of each contract on power flow of each transmission line is computed based on angle decomposition. Contract-related flows are used as a measure for “extent of use” of transmission network capacity and consequently transmission pricing. The presented approach is applied to a 4-bus test system and IEEE 30-bus test system.

Keywords—Deregulation, Power electric markets, Transmission pricing methodologies, decoupled Newton-Raphson power flow.

I. INTRODUCTION

TRANSMISSION pricing is an important issue in restructured power systems. Different usage-based methods have been presented for transmission pricing [1]-[3]. Many networks use *postage stamp rate* method for transmission pricing [1], [4]. This method is like mailing a letter within a country. This method assumes that the entire transmission system is used, regardless of the actual facilities that carry the transmission services. In *postage stamp* method network users are charged based on the magnitude of their transacted power and average embedded cost of the network. In this method users are not differentiated by the “extent of use” of network facilities. *Contact path* method is based on the assumption that power flows through a certain, prespecified path [1]-[4]. In this method first the least cost electrical path between generation and load points is determined for a given transaction. The transaction is charged a *postage stamp rate* that is computed either separately for each transmission system or as a grid average. In reality the actual path taken by a transaction may be quite different from the specified contract path. In *MW mile* method MW flows related to each transaction are computed in all transmission lines using DC power flow. To compute the transmission charge of a given transaction, the magnitude of its MW flow on every line is multiplied by its length and a weighting factor reflecting the cost per unit capacity of the line and summed

over all transmission lines. This method ensures the full recovery of fixed transmission cost and approximately reflects the actual usage of transmission network. *MVA mile* method is an extended version of the *MW mile* method [1], [8]. This method includes charging for reactive power in addition to the charging for active power. In this method MVA flows related to each transaction are computed in all transmission lines using tracing methods or sensitivity factors. In *Distribution factors* method distribution factors are computed using linear power flow [1], [6], [9]-[11]. In general, generation distribution factors are used to analyze system security and contingency. They are used to approximately determine the contribution of generations and loads on transmission line flows. Distribution factors can be used to allocate transmission cost to transactions, generators, or loads. In *tracing algorithms* first contribution of transmission users in network usage is determined based on proportional sharing principle [1], [8], [12]-[16]. There are two tracing algorithms, which are recognized as Bialek’s and Kirchen’s tracing algorithms. Tracing algorithms are extended to allocate fixed transmission costs based on contribution of transmission users in network usage. Some *AC Power Flow* methods including *AC Flow Sensitivity*, *Full AC Power Flow Solution*, and *Power Flow Decomposition* have been proposed to allocate transmission cost [1], [3], [7], [17]-[20]. In *AC Flow Sensitivity* method the sensitivity of transmission line flows to the bus power injections are derived from AC power flow models. This method uses the same logic of the DC flow distribution factors. In *Full AC Power Flow Solution* two power flow simulations are performed to determine the combined impacts caused by the transactions on the system: one for base case, no transactions, and one for the operating case including all the transactions. For each transaction t two power flow simulations are also performed. In one case only transaction t is included and in the other all transactions except for t are included. Marginal and incremental impact of each individual transaction on the system is obtained by comparing the results of these two simulations with the base case. Then the “fair resource allocation” problems are solved to distribute the MW/ MVAR line flows to each transaction. The *Power Flow Decomposition* method is based on superposition of all transactions on the system. In this method the network flows are decomposed into components associated with individual transactions plus one interaction component to account for the nonlinear nature of power flow models.

In this paper a decomposed power flow method is presented. In order to allocate transmission fixed cost first the contribution of each transaction in voltage angles is computed using decomposed DC power flow. Then the computed

M. Oloomi Buygi is with the Department of Power System Engineering, Shahrood University of Technology, Shahrood, Iran (e-mail: moloomi@shahrood.ac.ir).

M. Reza. Salehizadeh is with Islamic Azad University, Fars Science & Research College (e-mail: m.salehizadeh@seiau.ir).

solution is corrected in different iteration of decomposed decoupled Newton-Raphson power flow to take into account non-linear nature of the system. Then the contribution of each transaction in power flow of transmission lines is computed based on components of voltage angles.

The paper is organized as follows. In section II a decomposed decoupled power flow method is presented to compute the contributions of contacts on voltage angles. In section III contribution of contacts in line power flows is computed. Transmission pricing based on decomposed line power flows is described in section IV. The proposed method is applied to a 4-bus test system and IEEE 30-bus test system in section V. Conclusion in section VI closes the paper.

II. VOLTAGE ANGLE DECOMPOSITION

In order to compute the contribution of each contract on the power flow of each line, first the contribution of each contract on the voltage angle of each bus is determined. A primary solution for angle allocation is computed by DC power flow:

$$\delta^{(0)} = \delta^{dc} = \mathbf{B}^{-1} \mathbf{P}_{sch} \quad (1)$$

where $\delta^{(0)}$ is voltage angles vector and is equal to $\delta^{(0)} = [\delta_2^{(0)} \ \delta_3^{(0)} \ \dots \ \delta_{nb}^{(0)}]^T$, \mathbf{P}_{sch} is vector of scheduled power and is equal to $\mathbf{P}_{sch} = [P_{sch2} \ P_{sch3} \ \dots \ P_{schnb}]^T$, nb is number of buses, and \mathbf{B} is the imaginary part of admittance matrix if all lines are assumed lossless. It is assumed that bus 1 is slack bus. Total scheduled power in each bus is equal to sum of scheduled power of each contract:

$$\mathbf{P}_{sch} = \sum_{k=1}^{nc} \mathbf{P}_{sch}^{(k)} \quad (2)$$

where nc is number of contracts and $\mathbf{P}_{sch}^{(k)}$ is the vector of scheduled power of contract k . Here a contract means a bilateral contract, set of transactions of a scheduling coordinator, or set of transactions of a power pool. It is assumed that: 1) generation and consumption of each contract are equal, 2) non of contacts have generation or load in reference bus, and 3) generator of reference bus is responsible to compensate power losses. Substituting (2) in (1) yields:

$$\delta^{(0)} = \sum_{k=1}^{nc} \delta^{(0,k)} \quad (3)$$

where $\delta^{(v,k)}$ is the contribution of contract k in voltage angles in iteration v . $\delta^{(0,k)}$ is defined as follows:

$$\delta^{(0,k)} = \mathbf{B}^{-1} \mathbf{P}_{sch}^{(k)} \quad (4)$$

using (4) the contribution of each contract in voltage angle of each bus is computed. According to (4) in computing $\delta^{(0,k)}$ it is assumed that the system is linear. To take into account system non-linearity, $\delta^{(0,k)}$ is corrected using decoupled Newton-Raphson power flow. If resistance of transmission lines is neglected and voltage is assumed to be 1 pu at each bus, injection power of bus i at iteration v can be computed as

follows:

$$\mathbf{P}_{cal\ i}^{(v)} = \sum_{j=1}^{nb} \frac{1}{X_{ij}} \sin(\delta_i^{(v)} - \delta_j^{(v)}) \quad (5)$$

Substituting $\delta^{(v)} = \sum_{k=1}^{nc} \delta^{(v,k)}$ in (5) and assuming $\delta_i^{(v)} - \delta_j^{(v)}$

is small yields:

$$\mathbf{P}_{cal\ i}^{(v)} = \sum_{k=1}^{nc} \mathbf{P}_{cal\ i}^{(v,k)} \quad (6)$$

where $\mathbf{P}_{cal\ i}^{(v,k)}$ is the contribution of contract k in injection power of bus i at iteration v . In each iteration of decoupled Newton-Raphson $\Delta \delta^{(v)}$ can be calculated as follows:

$$\Delta \delta^{(v)} = \mathbf{J}_{11}^{-1} (\mathbf{P}_{sch} - \mathbf{P}_{cal}^{(v)}) \quad (7)$$

Substituting (2) and (6) in (7) yields:

$$\Delta \delta^{(v,k)} = \mathbf{J}_{11}^{-1} (\mathbf{P}_{sch}^{(k)} - \mathbf{P}_{cal}^{(v,k)}) \quad (8)$$

The primary solution is corrected at each iteration of decoupled Newton-Raphson as follows:

$$\delta^{(v,k)} = \delta^{(v-1,k)} + \Delta \delta^{(v,k)} \quad (9)$$

In this way the linear DC power flow solution is forced to go toward non-linear AC solution through piecewise lines. Therefore, system non-linearity is taken into account by correcting the contribution of contracts in voltage angles in each iteration of decoupled Newton-Raphson. As decoupled Newton-Raphson converges, the contribution of each contract in each voltage angle is computed considering system non-linearity.

III. CONTRIBUTION OF CONTRACTS IN LINE POWER FLOWS

After computing the contribution of each contract in each voltage angle, the contribution of each contract in power flow of each transmission line can be computed as follows:

$$\mathbf{P}_{line\ ij}^{(k)} = \frac{1}{X_{ij}} \sin(\delta_i^{(k)} - \delta_j^{(k)}) \quad (10)$$

where $\mathbf{P}_{line\ ij}^{(k)}$ is the contribution of contract k in power flow of line ij and $\delta_i^{(k)}$ is the contribution of contract k in voltage angle of bus i . Voltage angle error in bus i and line power error in line ij is defined as follows:

$$\text{VAE}_i = \delta_i - \sum_{k=1}^{nc} \delta_i^{(k)} \quad (11)$$

$$\text{LPE}_{ij} = \mathbf{P}_{line\ ij} - \sum_{k=1}^{nc} \mathbf{P}_{line\ ij}^{(k)} \quad (12)$$

where $\mathbf{P}_{line\ ij}$ is the total power of line ij . In section V it is shown that VAE_i and LPE_{ij} be small and can be neglected.

IV. TRANSMISSION PRICING

The first step for transmission pricing is to determine the extent-of-use criterion. In the proposed method the extent-of-

use of contract k in transmission line ij is equal to the contribution of contract k in power of line ij . Some contacts produce counter flow in some lines. Counter flows not only does not occupy transmission capacity but also release transmission capacity. Therefore, it is assumed that the extent-of-use of contracts that create counter flow in a line is zero in this line. Hence the extent-of-use criterion is defined as follows:

$$U_{ij}^{(k)}(h) = \begin{cases} P_{line\ ij}^{(k)}(h) & \text{if } P_{line\ ij}^{(k)}(h) \cdot P_{line\ ij}(h) > 0 \\ 0 & \text{if } P_{line\ ij}^{(k)}(h) \cdot P_{line\ ij}(h) \leq 0 \end{cases} \quad (12)$$

where $U_{ij}^{(k)}(h)$ is the extent-of-use of contract k in line ij at hour h . Suppose A_{ij} is the value that must be returned in one hour due to investment and operation cost of line ij . Assume $P_{line\ ij}(h)$, $P_{line\ ij}^{(k)}(h)$ and $U_{ij}^{(k)}(h)$ are constant during hour h . The share of contract k in return value of line ij at hour h is equal to:

$$A_{ij}^{(k)}(h) = \frac{U_{ij}^{(k)}(h)}{\sum_{j=1}^{nc} U_{ij}^{(j)}(h)} A_{ij} \quad (13)$$

The share of contract k in return value of line ij from hour h_1 to hour h_2 is equal to:

$$A_{ij}^{(k)}(h_1, h_2) = \sum_{h=h_1}^{h_2} A_{ij}^{(k)}(h) \quad (14)$$

in (14) investment and operation cost of line ij is allocated to different contracts base on hourly use of the network. Costs can be allocated based on the use of contracts from the network capacity at daily, weakly, monthly or yearly peak load.

V. NUMERICAL RESULTS

A) Four-Bus Test System

Consider the 4-bus test system that shown in Fig. 1. Parameters of transmission lines, generation data, and load data are given in Tables I and II. Table III shows the active

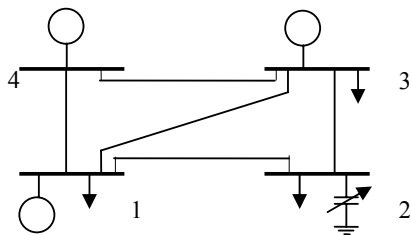

Fig. 1 Four-bus test system

TABLE I
PARAMETERS OF TRANSMISSION LINES OF 4-BUS TEST SYSTEM

From bus	To bus	Resistance (pu)	Inductance (pu)	Limit (MW)
1	2	0.02	0.08	250
1	3	0.03	0.12	250
1	4	0.01	0.05	150
2	3	0.02	0.06	150
3	4	0.01	0.03	150

TABLE II
GENERATION AND LOAD DATA OF 4-BUS TEST SYSTEM

Bus No	Bus Type	Generation (MW)	Load (MW)
1	PV	500	500+j100
2	PV	0	300+j50
3	PV	400	100+j30
4	Slack	---	0+j0

TABLE III
ACTIVE POWER CONTRACTS OF 4-BUS TEST SYSTEM IN MW

	Bus No. 1	Bus No. 2	Bus No. 3
1- Power Pool contracts	400	-300	-100
2- Bilateral contact 1	-400	0	400
3- Bilateral contact 2	100	-100	0

power contracts. Voltage angles and the share of contracts on the voltage angles are computed using decomposed DC power flow. The computed voltage angles and the share of contacts in voltage angles are used as initial solution for decomposed decoupled Newton-Raphson power flow in order to correct them and consider the effects of system non-linearity. Decomposed decoupled Newton-Raphson power flow converges in four iterations. The process stops when the max of absolute of voltage angle deviations is less than $1e-15$ radian. Tables IV, V, VI and VII show the voltage angles, line power flows, and the share of contracts on voltage angles and line power flows. Voltage angle error for different buses and line power error for different lines are shown on these tables.

These tables show that $\sum_{k=1}^{nc} \delta_i^{(k)}$ and $\sum_{k=1}^{nc} P_{line\ ij}^{(k)}$ are equal to

δ_i and $P_{line\ ij}$ respectively with an acceptable approximation.

The share of different contracts in return value of different lines in percentage i.e.

$$A_{ij}^{(k)}(h) = (A_{ij}^{(k)}(h) / A_{ij}) \cdot 100$$

is given in Table VIII. As Tables V and VII show contract 2 creates counter power flow in line 1-2 and hence only contracts 1 and 3 should pay for this line base on their power flow shares in this line (see Table VIII). Contracts 1 and 3 create counter power flow in lines 1-3, 1-4, and 3-4 and hence only contact 2 should pay for these lines (see Table VIII). None of the contracts create counter power flow in line 2-3 and hence all contacts should pay for this line base on their power flow shares in this line (see Table VIII).

TABLE IV
THE SHARE DIFFERENT CONTACTS IN VOLTAGE ANGLES OF 4-BUS TEST SYSTEM COMPUTED USING DECOMPOSED DC POWER FLOW

Bus No.	$\delta_i^{(0)}$ (deg)	$\delta_i^{(0,1)}$ (deg)	$\delta_i^{(0,2)}$ (deg)	$\delta_i^{(0,3)}$ (deg)	VAE _i (deg)
1	-0.9143	3.4743	-5.1200	0.7314	0
2	-7.9361	-5.5955	-0.4389	-1.9017	0
3	0.5486	-2.0846	3.0720	-0.4389	0
4	0	0	0	0	0

TABLE V
THE SHARE DIFFERENT CONTACTS IN LINE POWER FLOWS OF 4-BUS TEST SYSTEM COMPUTED USING DECOMPOSED DC POWER FLOW

Line No.	P _{line ij} ⁽⁰⁾ (pu)	P _{line ij} ⁽¹⁾ (pu)	P _{line ij} ⁽²⁾ (pu)	P _{line ij} ⁽³⁾ (pu)	LPE _i (pu)
1-2	1.5281	1.9705	-1.0201	0.5743	-0.0035
1-3	-0.2127	0.8072	-1.1874	0.1702	0.0028
1-4	-0.3191	1.2120	-1.7849	0.2553	0.0016
2-3	-2.4591	-1.0206	-1.0206	-0.4255	-0.0077
3-4	0.3191	-1.2125	1.7864	-0.2553	-0.0006

TABLE VI
THE SHARE DIFFERENT CONTACTS IN VOLTAGE ANGLES OF 4-BUS TEST SYSTEM COMPUTED USING DECOMPOSED DECOUPLED NEWTON-RAPHSON POWER FLOW

Bus No.	δ_i (deg)	$\delta_i^{(1)}$ (deg)	$\delta_i^{(2)}$ (deg)	$\delta_i^{(3)}$ (deg)	VAE _i (deg)
1	-0.9165	3.5000	-5.1511	0.7319	-0.0027
2	-7.9617	-5.6448	-0.4431	-1.9032	-0.0293
3	0.5499	-2.0975	3.0828	-0.4391	-0.0037
4	0	0	0	0	0

TABLE VII
THE SHARE DIFFERENT CONTACTS IN LINE POWER FLOWS OF 4-BUS TEST SYSTEM COMPUTED USING DECOMPOSED DECOUPLED NEWTON-RAPHSON POWER FLOW

Line No.	P _{line ij} ⁽⁰⁾ (pu)	P _{line ij} ⁽¹⁾ (pu)	P _{line ij} ⁽²⁾ (pu)	P _{line ij} ⁽³⁾ (pu)	LPE _i (pu)
1-2	1.5332	1.9866	-1.0260	0.5747	0.0022
1-3	-0.2133	0.8128	-1.1934	0.1703	0.0029
1-4	-0.3199	1.2210	-1.7956	0.2555	0.0007
2-3	-2.4668	-1.0312	-1.0250	-0.4258	-0.0152
3-4	0.3199	-1.2200	1.7926	-0.2555	0.0022

TABLE VIII
THE SHARE OF CONTRACTS IN RETURN VALUE OF LINES IN PERCENTAGE

Line No.	A _{ij} ⁽¹⁾ (h)	A _{ij} ⁽²⁾ (h)	A _{ij} ⁽³⁾ (h)
1-2	77.631	0	22.369
1-3	0	100	0
1-4	0	100	0
2-3	41.55	41.3	17.149
3-4	0	100	0

B) IEEE 30-Bus Test System

In this section decomposed power flow is applied to IEEE 30-bus test system [21], which is shown in Fig. 2. Table IX

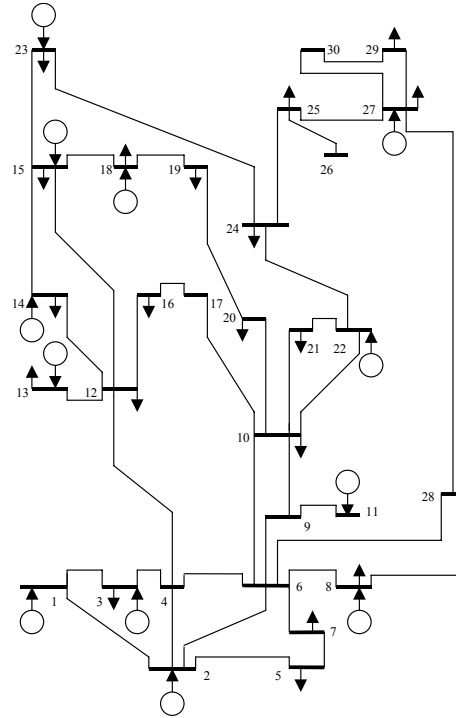

Fig. 2 Single line diagram of IEEE 30 buses test system

TABLE IX
ACTIVE POWER CONTRACTS OF IEEE 30-BUS TEST SYSTEM IN MW

	Generation	Consumption
1- Power Pool contracts	200 MW bus 1	100 MW at bus 7 20 MW at bus 8 50 MW bus 21 30 MW at bus 29
2- Scheduling coordinator 1	150 MW at bus 23	100 MW at bus 10 50 MW at bus 25
3- Scheduling coordinator 2	80 MW at bus 13 120 MW at bus 14	100 MW at bus 3 100 MW at bus 19

shows the active power contracts that are considered for IEEE 30-bus test system. Tables X and XI show the voltage angles, line power flows, and the share of contracts on voltage angles and line power flows. Voltage angle error for different buses and line power error for different lines are shown in these tables. These tables show that voltage angle errors and line power errors are small enough. The share of different contracts in return value of different lines for in percentage is given in table XII. Table XI shows that

- Contact 1 creates counter power flow in lines 3-4, 4-12, 12-14, and 10-22 and hence only contacts 2 and 3 should pay for these lines base on their power flow shares.
- Contact 2 creates counter power flow in lines 1-3, 6-7, 14-15, and 25-27 and hence only contacts 1 and 3 should pay for these lines base on their power flow shares.
- Contact 3 creates counter power flow in lines 1-2, 2-5, 2-6, 4-6, 5-7, 6-8, 6-9, 6-10, 9-10, 28-27, 8-28 and 6-28 and hence only contacts 1 and 2 should pay for these lines base on their power flow shares.

TABLE X

THE SHARE OF CONTACTS IN VOLTAGE ANGLES OF IEEE 30-BUS TEST SYSTEM COMPUTED USING DECOMPOSED DECOUPLED NEWTON-RAPHSON POWER FLOW

Bus No.	δ_i	$\delta_i^{(1)}$	$\delta_i^{(2)}$	$\delta_i^{(3)}$	VAE _i
1	19.534	19.260	3.0242	-2.7503	1.2722e-014
2	15.381	14.771	2.9747	-2.3647	1.5903e-014
3	11.689	12.497	3.1837	-3.9922	1.1132e-014
4	12.255	11.113	3.2164	-2.0749	1.4312e-014
5	10.443	9.6627	2.8371	-2.0571	1.4312e-014
6	10.21	9.2604	2.6997	-1.75	1.1132e-014
7	7.5539	6.6745	2.7566	-1.8772	1.1132e-014
8	9.6609	8.7289	2.6491	-1.7172	1.2722e-014
9	7.7389	6.7506	1.5549	-0.5666	1.2722e-014
10	6.432	5.4232	0.9494	0.0593	1.2722e-014
11	7.7389	6.7506	1.5549	-0.5666	1.2722e-014
12	24.115	7.8327	6.9879	9.2942	1.2722e-014
13	30.532	7.8327	6.9879	15.711	1.2722e-014
14	32.252	7.391	8.5487	16.313	6.3611e-015
15	24.872	7.0463	9.7666	8.0596	1.2722e-014
16	16.74	6.8278	4.4694	5.4425	1.2722e-014
17	9.5684	5.8506	2.0205	1.6973	1.2722e-014
18	12.871	6.4786	6.6826	-0.2898	1.1132e-014
19	5.7752	6.1429	4.8591	-5.2268	1.2722e-014
20	5.9364	5.9662	3.8993	-3.9291	1.1927e-014
21	6.4032	4.016	1.9372	0.4499	1.2722e-014
22	7.0702	4.2487	2.2484	0.5730	1.1132e-014
23	29.676	6.0041	18.154	5.5177	1.2722e-014
24	12.891	4.6111	6.1603	2.1200	1.2722e-014
25	3.1326	3.5791	-1.269	0.8226	8.349e-015
26	3.1326	3.5791	-1.269	0.8226	8.349e-015
27	2.9248	2.9248	0.0000	0.0000	7.1562e-015
28	9.3371	8.4901	2.4078	-1.5608	1.2722e-014
29	-2.1983	-2.1983	0.0000	0.0000	4.3733e-015
30	0	0	0	0	0

10-21	0.0067	0.3279	-0.2302	-0.0910	-2.086e-5
10-22	-0.0743	0.1367	-0.1512	-0.0598	2.6443e-6
21-22	-0.4933	-0.1721	-0.2302	-0.0910	-9.467e-6
15-23	-0.4145	0.0900	-0.7221	0.2196	0.0020
22-24	-0.5666	-0.0353	-0.3811	-0.1508	-0.0007
23-24	1.0695	0.0900	0.7697	0.2195	0.0097
24-25	0.5149	0.0547	0.3928	0.0688	0.0014
25-26	0	0	0	0	0
25-27	0.0174	0.0547	-0.1061	0.0688	5.1616e-6
28-27	0.2820	0.2449	0.1061	-0.0688	0.0002
27-29	0.2150	0.2150	0	0	1.110e-16
27-30	0.0847	0.0847	0	0	0
29-30	-0.0847	-0.0847	0	0	1.388e-17
8-28	0.0283	0.0208	0.0211	-0.0136	4.4658e-8
6-28	0.2544	0.2244	0.0851	-0.0551	2.8131e-6

- Contacts 1 and 2 create counter power flow in lines 19-20 and 10-20 and hence only contact 3 should pay for these lines. Share of contacts 1 and 2 in power flow of line 12-13 is zero and hence only contact 3 should pay for this line.
- Contacts 1 and 3 create counter power flow in lines 12-15 and 15-23 and hence only contact 2 should pay for these lines.
- Contacts 2 and 3 create counter power flow in lines 2-4 and 10-21 and hence only contact 1 should pay for these lines. Share of contacts 2 and 3 in power flow of lines 27-29, 27-30, and 29-30 is zero and hence only contact 1 should pay for these lines.
- Non of contacts create counter power flow in lines 12-16, 16-17, 15-18, 18-19, 10-17, 21-22, 22-24, 23-24, and 24-25 and hence all contacts should pay for these lines base on their power flow shares.
- In this operating point generation and load of buses 11

TABLE XI

THE SHARE OF CONTACTS IN LINE POWER FLOWS OF IEEE 30-BUS TEST SYSTEM COMPUTED USING DECOMPOSED DECOUPLED NEWTON-RAPHSON POWER FLOW

Line No.	P _{line ij}	P _{line ij} ⁽¹⁾	P _{line ij} ⁽²⁾	P _{line ij} ⁽³⁾	LPE _i
1-2	1.2596	1.3613	0.0150	-0.1170	-0.0003
1-3	0.7370	0.6359	-0.0150	0.1170	0.0008
2-4	0.3140	0.3673	-0.0243	-0.0291	-9.355e-5
3-4	-0.2607	0.63728	-0.0150	-0.8828	9.8572e-5
2-5	0.4341	0.4490	0.0121	-0.0271	-5.736e-5
2-6	0.5112	0.5447	0.0272	-0.0609	-0.0001
4-6	0.8619	0.7811	0.2178	-0.1370	4.4583e-5
5-7	0.4345	0.4494	0.0121	-0.0271	-1.964e-5
6-7	0.5652	0.5502	-0.0121	0.0271	1.5635e-5
6-8	0.2283	0.2208	0.0211	-0.0136	3.2744e-7
6-9	0.2073	0.2105	0.0961	-0.0993	-2.390e-6
6-10	0.1185	0.1204	0.0549	-0.0568	-3.194e-6
9-11	0	0	0	0	0
9-10	0.2073	0.2106	0.0961	-0.0993	-6.684e-7
4-12	-0.8028	0.2235	-0.2570	-0.7700	-0.0006
12-13	-0.7983	0	0	-0.7983	0
12-14	-0.5532	0.0301	-0.1064	-0.4775	-0.0007
12-15	-0.1014	0.1053	-0.3718	0.1652	0.0001
12-16	0.6460	0.0883	0.2212	0.3381	0.0015
14-15	0.6432	0.0301	-0.1064	0.7188	-0.0007
16-17	0.6461	0.0883	0.2212	0.3381	0.0014
15-18	0.9516	0.0453	0.2462	0.6646	0.0045
18-19	0.9562	0.0453	0.2463	0.6661	0.0016
19-20	-0.0414	0.0453	0.2463	-0.3330	1.6828e-5
10-20	0.0414	-0.0453	-0.2462	0.3328	-0.0002
10-17	-0.6475	-0.0883	-0.2212	-0.3383	-0.0003

TABLE XII

THE SHARE OF DIFFERENT CONTRACTS IN RETURN VALUE OF DIFFERENT LINES IN PERCENTAGE

Line No.	A _{ij} ⁽¹⁾ (h)	A _{ij} ⁽²⁾ (h)	A _{ij} ⁽³⁾ (h)
1-2	98.909	1.0913	0
1-3	84.485	0	15.515
2-4	100	0	0
3-4	0	1.6743	98.326
2-5	97.378	2.6223	0
2-6	95.248	4.7519	0
4-6	78.197	21.803	0
5-7	97.378	2.6223	0
6-7	95.312	0	4.6879
6-8	91.296	8.7043	0
6-9	68.674	31.326	0
6-10	68.674	31.326	0
9-11	0	0	0
9-10	68.674	31.326	0
4-12	0	24.91	75.09
12-13	0	0	100
12-14	0	18.192	81.808
12-15	0	100	0
12-16	13.626	34.149	52.225
14-15	4.0094	0	95.991
16-17	13.626	34.149	52.225
15-18	4.7303	25.698	69.572
18-19	4.7303	25.698	69.572
19-20	0	0	100
10-20	0	0	100

10-17	13.626	34.149	52.225
10-21	100	0	0
10-22	0	71.661	28.339
21-22	34.886	46.661	18.453
15-23	0	100	0
22-24	6.2248	67.2	26.575
23-24	8.2994	71.458	20.243
24-25	10.575	76.129	13.296
25-26	0	0	0
25-27	44.302	0	55.698
28-27	69.801	30.199	0
27-29	100	0	0
27-30	100	0	0
29-30	100	0	0
8-28	49.747	50.253	0
6-28	72.516	27.484	0

and 26 is zero. Bus 11 is connected only to bus 9 and bus 26 is connected only to bus 25, hence the power flow of lines 9-11 and 25-26 is zero and non of contacts pay for them.

Table XII confirm above mentioned results.

VI. CONCLUSION

In this paper a new transmission pricing method base on voltage angle decomposition is presented. In this method the contribution of each contract on voltage angels and consequently on line power flows is computed. The extent-of-use of contract k on capacity of line ij is equal to the contribution of contract k on the power flow of line ij. The extent-of- use contacts that create counter power flow on a line is considered zero to encourage the contracts that release transmission capacity. Numerical studies show that voltage angle errors and line power errors are negligible.

REFERENCES

- [1] J. Pan, Y. Teklu, S. Rahman, and K. Jun, "Review of usage-based transmission cost allocation methods under open access," *IEEE Trans. on Power Systems*, vol. 15, no. 4, pp. 1218–1224, Nov. 2000.
- [2] M. Shahidehpour and M. Alomoush, *Restructured Electrical Power Systems*, Marcel Dekker Publishers, June 2001.
- [3] M. D. Ilic *et al.*, "Toward regional transmission provision and its pricing in New England," *Utility Policy*, vol. 6, no. 3, pp. 245–256, 1997.
- [4] H. H. Happ, "Cost of wheeling methodologies," *IEEE Trans. on Power Systems*, vol. 9, no. 1, pp. 147–156, Feb. 1994.
- [5] J. W. Marangon Lima, "Allocation of transmission fixed charges: An overview," *IEEE Trans. on Power Systems*, vol. 11, no. 3, pp. 1409–1418, Aug. 1996.
- [6] D. Shirmohammadi *et al.*, "Evaluation of transmission network capacity use for wheeling transactions," *IEEE Trans. on Power Systems*, vol. 4, no. 4, pp. 1405–1413, Oct. 1989.
- [7] D. Shirmohammadi *et al.*, "Cost of transmission transactions: An introduction," *IEEE Trans. on Power Systems*, vol. 6, no. 4, pp. 1546–1560, Nov. 1991.
- [8] J. Bialek, "Allocation of transmission supplementary charge to real and reactive loads," *IEEE Trans. on Power Systems*, vol. 13, no. 3, pp. 749–754, Aug. 1998.
- [9] W. Y. Ng, "Generalized generation distribution factors for power system security evaluations" *IEEE Trans. on Power Apparatus and Systems*, vol. 100, no. 3, pp. 1001–1005, Mar. 1981.
- [10] H. R. Rudnick, R. Palma, and J. E. Fernandez, "Marginal pricing and supplement cost allocation in transmission open access," *IEEE Trans. on Power Systems*, vol. 10, no. 2, pp. 1125–1142, May 1995.
- [11] H. Singh, S. Hao, and A. Paralexopoulos, "Transmission congestion management in competitive electricity markets," *IEEE Transactions on Power Systems*, vol. 13, no. 2, pp. 672–680, May 1998.

- [12] J. Bialek, "Tracing the flow of electricity," *IEE Proc. Gener. Transm. Distrib.*, vol. 143, no. 4, pp. 313–320, July 1996.
- [13] J. Bialek, "Elimination of merchandise surplus due to spot pricing of electricity," *IEE Proc. Gener. Transm. Distrib.*, vol. 144, pp. 399–405, 1997.
- [14] J. Bialek, "Topological generation and load distribution factors for supplement charge allocation in transmission open access," *IEEE Trans. On Power Systems*, vol. 12, no. 3, pp. 1185–1193, Aug. 1997.
- [15] D. Kirschen, R. Allan, and G. Strbac, "Contribution of individual generations to loads and flows," *IEEE Trans. on Power Systems*, vol. 12, no. 1, pp. 52–60, Feb. 1997.
- [16] G. Strbac, D. Kirschen, and S. Ahmed, "Allocating transmission system usage on the basis of traceable contributions of individual generations and loads to flows," *IEEE Trans. on Power Systems*, vol. 13, no. 2, pp. 527–534, May 1998.
- [17] M. E. Baran, V. Banunarayanan, and K. E. Garren, "A transaction assessment method for allocation of transmission services," *IEEE Trans. on Power Systems*, vol. 14, no. 3, pp. 920–928, Aug. 1999.
- [18] S. Hao and A. Papalexopoulos, "Reactive power pricing and management," *IEEE Trans. on Power Systems*, vol. 12, no. 1, pp. 95–104, Feb. 1997.
- [19] Y.-M. Park, J.-B. Park, J.-U. Lim, and J.-R. Won, "An analytical approach for transmission costs allocation in transmission system," *IEEE Trans. on Power Systems*, vol. 13, no. 4, pp. 1407–1412, Nov. 1998.
- [20] A. Zobian and M. D. Ilic, "Unbundling of transmission and ancillary services—Part I: Technical issues and Part II: Cost-based pricing framework," *IEEE Trans. on Power Systems*, vol. 12, no. 2, pp. 539–558, May 1997.
- [21] M. Oloomi Buygi, G. Balzer, H. Modir Shanechi, and M. Shahidehpour, "Market based transmission expansion planning," *IEEE Trans. on Power Systems*, vol. 19, no. 4, pp. 2060–2067, Nov. 2004.

Majid Oloomi Buygi received the BSc. and MSc. degrees in Electrical Engineering from the Ferdowsi Univ., Mashhad, Iran, in 1993 and 1996 and the Ph.D. degree from Darmstadt Univ. of Technology, Germany in 2004, respectively. He is now the head of Power System Engineering Department, Shahrood University of Technology, Iran. His main research interests include power system planning, operating, control, and risk management.

Mohammad Reza Salehizadeh received the BSc. degree in Electrical Power System Engineering from Power and Water University of Technology, Tehran, Iran in 2002. He received the MSc. degree in Electrical Control System Engineering from the Shahrood University of Technology, Shahrood, Iran in 2005. He is now with Islamic Azad University, Fars Science & Research College. His main research interests include intelligent methods and applications, power system operation and control.