

Performance Evaluation of an Amperometric Biosensor using a Simple Microcontroller based Data Acquisition System

V. G. Sangam and Balasaheb M. Patre

Abstract—In this paper we have proposed a methodology to develop an amperometric biosensor for the analysis of glucose concentration using a simple microcontroller based data acquisition system. The work involves the development of Detachable Membrane Unit (enzyme based biomembrane) with immobilized glucose oxidase on the membrane and interfacing the same to the signal conditioning system. The current generated by the biosensor for different glucose concentrations was signal conditioned, then acquired and computed by a simple AT89C51-microcontroller. The optimum operating parameters for the better performance were found and reported. The detailed performance evaluation of the biosensor has been carried out. The proposed microcontroller based biosensor system has the sensitivity of 0.04V/g/dl, with a resolution of 50mg/dl. It has exhibited very good inter day stability observed up to 30 days. Comparing to the reference method such as HPLC, the accuracy of the proposed biosensor system is well within $\pm 1.5\%$. The system can be used for real time analysis of glucose concentration in the field such as, food and fermentation and clinical (In-Vitro) applications.

Keywords—Biosensor, DMU, Glucose oxidase and Microcontroller.

I. INTRODUCTION

BIOSENSORS are the devices that consist of two major components namely a biological entity that recognizes the target analyte and the transducer that translates the biorecognition event into an electrical signal. The amperometric biosensors measure the changes of current of a working electrode resulted from biochemical and electrochemical reaction. In amperometric biosensors the potential at the electrode is held constant while the current is measured. The performance of the biosensor will mainly depend on, the properties of biosensing (enzyme) membrane and to a little extent on the instrumentation system used to acquire the signal generated by biochemical reaction at the biosensing membrane [1-4]. The amperometric biosensors are

This work was financially supported by the grants of All India Council of Technical Education-Government of India-New Delhi-F.No.8020/RID/TAPTECH-17.

Dr. B.M. Patre is Professor and Dean (R & D) at S.G.G.S Institute of Engineering and Technology, Nanded, India, email: bmpatre@yahoo.com

V. G. Sangam is Research scholar at S.G.G.S Institute of Engineering and Technology, Nanded, India, email: sangamvg@yahoo.com

known to be reliable, cheap and highly sensitive for the analysis of bioparameters present in food ingredients and environment [5-6].

The developments in the instrumentation system have laid a good foundation for the growth of biosensors. In the literature the development of amperometric biosensor using dissolved oxygen electrode and their related instrumentation system is discussed in detail [7-9]. The performance of the biosensor can be improved and studied in detail by using advanced instrumentation system [10-15]. The performance of the amperometric biosensor will be better when there will be an appropriate interface between biosensing membrane and the related instrumentation system.

The goal of the proposed work involves development of amperometric biosensor with a simple microcontroller based data acquisition system and the detailed performance analysis of the biosensor for the analysis of glucose concentration.

II. MATERIALS

A. Materials used to develop enzyme membrane

Glucose Oxidase (GOD) from *Aspergillus niger*, Lysozyme, and Glutaraldehyde from Sigma USA, cellophane membrane HiMedia –India (30 micrometers thick), Oxygen permeable Teflon membrane (13 micrometers) and an electrode (two electrode system) from Century instruments, India have been used.

A.1. Preparation of enzyme membrane

The preparation of enzyme membrane for the analysis of glucose concentration, glucose oxidase (GOD) was immobilized by cross linking method with modified protocol as reported in [16-18]. 5 mg of GOD was dissolved in one ml of distilled water, and 30 mg of Lysozyme in one ml distilled water was prepared. Glutaraldehyde solution was prepared by appropriate dilution of 70% glutaraldehyde. On a 2 cm x 2 cm cellophane membrane, 12 micro liter of GOD and 30 micro liter of Lysozyme were placed and mixed thoroughly using glass rod. 50 micro liter of glutaraldehyde was then added and mixed thoroughly so that both can be distributed uniformly throughout enzyme membrane. The mixture is allowed to remain for air dry for about 70 minutes, and then the enzyme membrane was washed with distilled water later followed by two times washing with 0.05 monobasic sodium phosphate buffer of pH 7.0 to remove the excess

glutaraldehyde. The total thickness of the enzyme layer containing GOD, Lysozyme, and glutaraldehyde along with the cellophane membrane on which it is deposited is approximately 270 micrometers.

A.2. Enzyme Electrode with Detachable Membrane Unit (DMU)

The electrode has anode and cathode, the cathode being the working electrode made of gold, and anode being the reference electrode made of silver/silver chloride. The interconnectivity between working electrode and reference electrode is through the electrolyte (KCl). The area of working electrode used here is 0.012cm^2 , and the area of reference electrode is 1.64cm^2 . As the area of working electrode is much smaller than the reference electrode there was no necessarily of using counter electrode.

The enzyme membrane on which glucose oxidase + lysozyme + glutaraldehyde are present and the oxygen ion selective membrane through which oxygen molecules (liberated because of biochemical reaction) will enter to the area of working electrode, constitute Detachable Membrane Unit (DMU). O-ring is used for tight securing of DMU to the electrode area. The oxygen ion membrane also prevents electrode poisoning due to electrochemical interfacing metal ions, ascorbic acid and metal chelating agents like citric acid. A 50 ml glass container with 30 ml sodium phosphate buffer solution is used as sample cell.

III. METHOD

The amperometric biosensor is operated in cathodic amperometric configuration. After applying a potential of -750 mV (negative) to the working electrode, the current (I) is produced and is proportional to the oxygen concentration (that is in-turn related to the amount of analyte). The current (I), will flow between the electrodes by means of a standard solution of KCl. This electrode compartment is separated from the biocatalyst (enzyme membrane) by a thin membrane permeable only to oxygen. The reaction involved at the Detachable Membrane Unit is shown in equations 1 and 2 respectively. The reduction of oxygen occurs at working electrode involving the acceptance of four electrons.

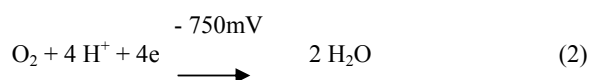
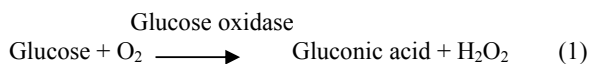

The reduction of oxygen (consumption of oxygen by the analyte) leads to the change in current and is linear to the analyte concentration. The resulting current was in the range of 100 nano amperes to 0.6 micro amperes. Using Current to voltage converter, preamplifier and instrumentation amplifier, it is converted and amplified to a level of 0-5Volts. The gain of the instrumentation amplifier is designed appropriately. The resulted analog signal was converted to an equivalent digital value and interfaced to microcontroller for computation.

B. Electronic Hardware System

The major components used in the design of electronic hardware system are,

- Signal conditioning system
- ADC and Microcontroller based Data Acquisition System (DAS)

B.1. Biasing Circuit

The significance of biasing circuit is to generate polarizing potential needed for the working electrode. Experimental results suggested that the working polarizing potential of the electrode can be between -700-800 mV. In our experiments better results were obtained at -750 mV. Here negative bias is given to the working electrode, i.e. biosensor is operated in cathodic amperometric configuration.

B.2. Signal Conditioning Circuit

The Current generated from enzyme electrode depends on analyte concentration, area of electrode and also on the protocol used to develop biosensing membrane [4]. The current was converted to voltage and amplified using signal conditioning circuit as shown in Fig 1.

The enzyme electrode output (i.e. current, I) is given to the input of the signal conditioning circuit. In the first stage, current is converted into a level of microvolt. The resulting voltage is given by

$$V_1 = 10 K \times I$$

In the next stage the resulted voltage V_1 is further amplified to volt range.

$$V_2 = \left(\frac{R_f}{R_2}\right) V_1$$

$$R_f = 61\text{K}, \text{ and } R_2 = 100 \Omega$$

$$V_2 = 610 V_1$$

The output of signal conditioning circuit, (V_2) was given to a high accuracy instrumentation amplifier INA 101 to maintain the level of 0-5 volts that is required for data acquisition system [19].

In our investigation the current observed, for the glucose concentration of 1gm/dl is 0.019 micro amps and for 15g/dl is 0.310 micro amps. An excellent linearity is observed for the intermediate values.

B.3. Analog to Digital Converter (ADC) and microcontroller based Data Acquisition System (DAS)

Eight bit ADC 0808 is used to convert the analog signal received from signal conditioning circuit to a digital data. It operates with +5V power supply voltage. The conversion time of ADC is 100 microsecond, and operates with 600-650 KHz clock frequency (here 630 KHz is used). The required clock frequency was generated using 555 timer, operating in the astable mode with 50 percent duty cycle.

Microcontroller AT89C51 is used for computation, which is

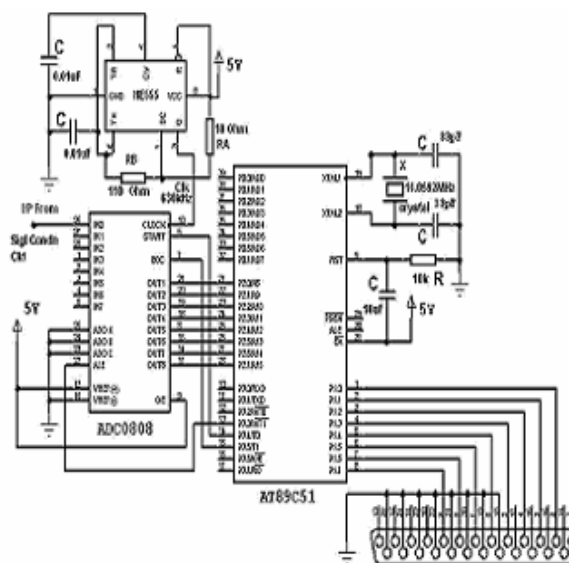

Fig. 2 Microcontroller based Data Acquisition System

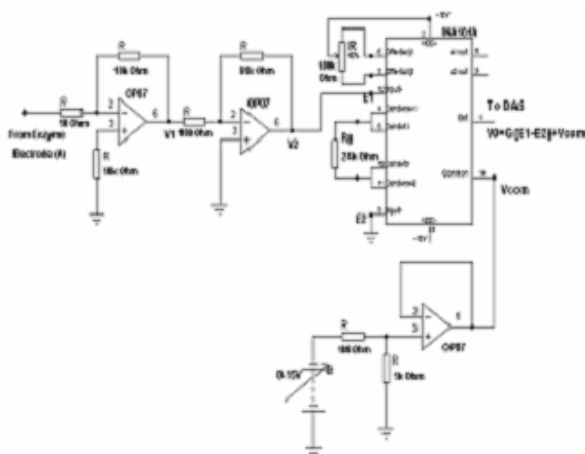

Fig. 1 Signal conditioning circuit

to calculate the unknown sample concentration of glucose. The converted data form the ADC is read from microcontroller and later it is transferred to the parallel port of PC to read the data [20]. AT89C51 microcontroller is an 8 bit and has been operated at 11.05 MHz clock frequency. It has 128 bytes of RAM and 64K ROM, two 16 bit Timer/counter, 32 I/O lines, four parallel I/O ports of each 8 bit, one programmable serial port and six interrupt ports.

Port 2 of microcontroller was used to get the converted data from ADC; port 1 was used to send the data to PC through parallel port. Port 3 was used for control signals. PC is used to display, to store and to analyze the computed data. The hardware used for data acquisition system is shown in Fig 3.

B.4. Programming AT89C51

The program used is in the assembly language. The generated Hex code was downloaded in to the EPROM of AT89C51. using universal programmer kit. Microcontroller was programmed to generate timer delay; timer 0 in mode 2 configuration was used. AT89C51 sends start of conversion signal (SOC) to ADC and later reads converted data (EOC) and stores in its internal RAM in sequence. During the real time analysis of the sample, the data has been read at the end of 180 seconds (biosensor reaches steady state at 180 seconds). The data are then transferred to computer through the parallel port.

C. Experimental Set up

The Detachable Membrane Unit (DMU) with enzyme electrode were held in sandwich form and secured tightly with an O-ring. This was connected to microcontroller through signal conditioning system. The experimental set up is shown in Fig 3. The activity of biosensor was measured by immersing the electrode in 50 ml glass container having about 30 ml buffer, and kept agitated continuously with air bubbled through portable air pump for two minutes, during the beginning of investigation. The sample to be analyzed was injected in to the buffer solution as shown in Fig 3. The amount of sample to be injected is optimized by experimentation. The glucose in the sample is oxidized because of biochemical and electrochemical reactions (equation 1 and 2). The variation in the current is monitored. The time taken to reach steady state is 180 seconds. The current response is converted to relative voltage. Fig 4 shows the steady state biosensor response with reference to voltage and time.

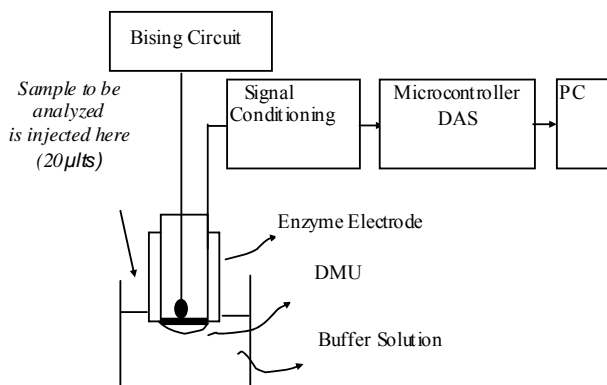

Fig. 3 Experimental set up

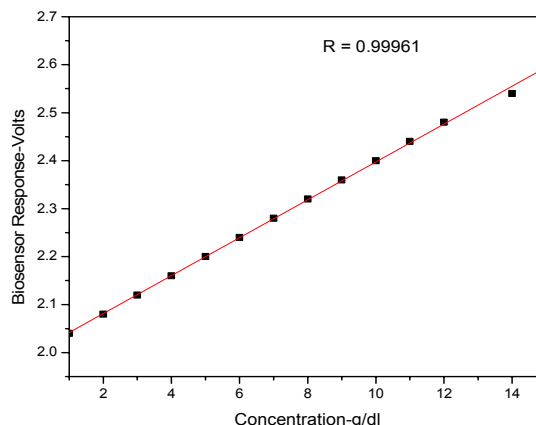

Fig. 5 Calibration plot of biosensor

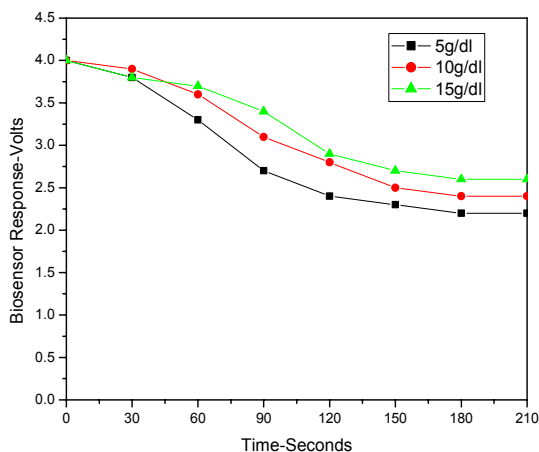

Fig. 4 Biosensor response showing the steady state

C.1. Calibration

The proposed amperometric biosensor set up was calibrated for different standard concentrations of glucose. Initially the out put of the signal conditioning circuit was adjusted to 2 V for zero concentration of glucose. Various glucose concentrations ranging between 0.5g/dl to 15 g/dl were used for the calibration. An excellent linearity was obtained with a high correlation coefficient of R=0.99961 as shown in Fig 5. It is also observed that calibration is reversible and repeatable.

IV. RESULTS AND DISCUSSION

Investigations have been carried out to find the effects of variables on the biosensor response, and the optimized conditions for the better performance were reported.

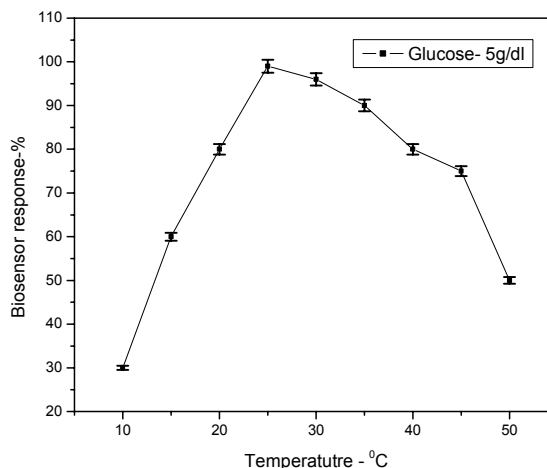

Fig. 6 Effect of temperature on biosensor response, with sodium phosphate buffer of pH 7.0. Error bars denote range of variation ± 1.5%.

Temperature affects the rate of reaction and thereby alters the response time, higher temperature gives faster response at the same time it also shifts equilibrium potential and gives nonlinear response [16]. The response of biosensor, at different temperatures ranging between 10⁰ C to 50⁰ C have been observed, with a temperature sensor Pt-100, and sodium phosphate buffer pH 7.0. From the Figure 6, it is clear that the biosensor output increases with an increase in temperature. The maximum linear response was observed between the temperature ranges of 20⁰C-30⁰C, and later it decreases. Performance of the biosensor was better at temperature 25⁰C ± 2⁰C, and it has been considered for experimentation.

The biosensor is stored in buffer solution and sample to be analyzed is injected in buffer solution. The variations in buffer solutions will vary the biosensor response. The effect of pH of buffer solution on biosensor was studied. The sodium phosphate buffer with different pH values ranging from 3-10 were used for the study. After measuring the initial activity at pH 7.0, the effect of pH on biosensor response was found by using known concentrations of glucose. The maximum response was observed at pH 7.0 and temperature 25⁰ C. With reference to the cathodic reaction shown in equation 2, there may be a tendency that the net change in H⁺ ions may lead to change in pH level [20], to overcome this, anode was cleaned with buffer solution after every 36 hrs of usage or after every 80 number of analyses.

The volume of the sample (analyte) injected for the analysis slightly affects the response time of the biosensor. Optimization of sample volume is important for faster response. High sample volume drastically decreases the response time of the sensor and a low volume leads to poor response of the sensor. The optimum volume of sample to be injected for analysis was found to be 20 micro liters, and the same has been used throughout the investigations.

The minimum time needed between two consecutive analyses is considered as the recovery time. Recovery time depends on the protocol used to develop the membrane, thickness of the membrane [2] and the electronic hardware used. Cathodic amperometric biosensor show quick return to base line by simply placing electrode in fresh buffer solution [17]. The recovery time observed here is 60 seconds. After every 80 analysis electrodes with DMU is washed in fresh phosphate buffer solution for about 60 seconds to get better performance.

The thickness of the enzyme membrane is considered as one of the important factor. Though it can be neglected during intensive stirred, studies were carried out to find the effect of the thickness of the enzyme membrane. The response of the biosensor for different membrane thickness obtained experimentally is shown in Figure 7. It was observed that higher the thickness lower the response of the sensor. It is not mean that resulting current depends on the thickness of the membrane, but it takes more time to reach the steady state. During the investigation it was also observed that. The influence of the membrane thickness on the sensitivity of the biosensor is negligible, but the variation in the response time has been observed for the membrane thickness (with the same pore size) with 40, 60, and 80 micro meters. Table 1 shows the response time for various membrane thicknesses. The influence of interference of the physiological species such as uric acid and ascorbic acid on the biosensor has been studied. Urea solution of various concentrations has been prepared ranging from 0.5g/dl to 10g/dl. The initial response of the sensor (enzyme membrane) was measured in the absence of urea, Later; the sensor was kept in the urea solution of known concentrations for about one hour. The sensor exhibited better results retaining as much as 95% original activity at higher

concentrations of urea. The same investigation has also been carried out to study the interference effect of ascorbic acid and the behavior of the sensor is shown in Figure 8. The main reason for the specificity is the amount of glucose oxidase and Lysozyme used to develop the DMU.

TABLE I
RESPONSE TIME OF THE BIOSENSOR FOR GLUCOSE CONCENTRATION 2G/DL

Thickness of the membrane in micrometers	Response time in seconds
40	160
60	180
80	220

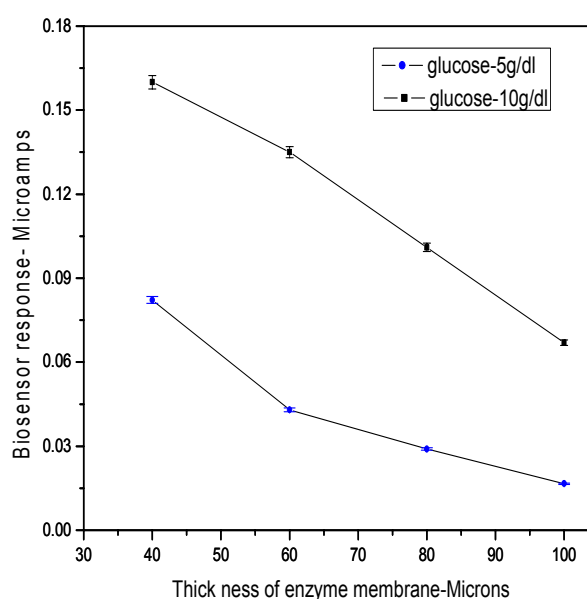

Fig. 7 Performance of biosensor for different thickness of enzyme membrane, observed at the end of 180 seconds.

Reproducibility of the results was tested by repeated number of analysis, performing about 80 analyses per day. The response of the biosensor was highly reproducible, as demonstrated by low standard deviation of 0.0056 for all the sample analysis.

An excellent inter day reproducibility was observed by the sensor, demonstrating long term operating stability. The stability of the biosensor depends on the stabilizing agent used to develop enzyme membrane. The incorporation of lysozyme during the process of immobilization contributes to the long term operating stability of the membrane [15-17] The long term operating stability of the biosensor was investigated by evaluating the response of the sensor (same DMU) for about

30 days. The sensor was calibrated everyday before the conduct of sample analysis. The sensor shown highest response in first 26 days with about 80 sample analyses per day, and then response was maintained at about 85% of the original response during 27th and 28th day, later it was reduced to 78% and the same is shown in Figure. 9.

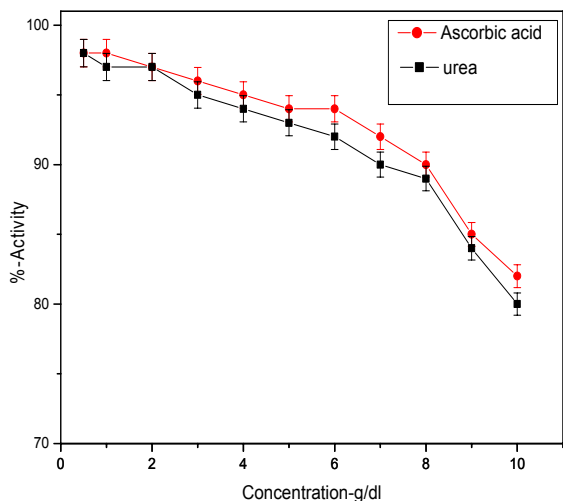

Fig. 8 Effect of different concentrations of urea and ascorbic acid on the biosensor. Error bars denote range of variation $\pm 2\%$.

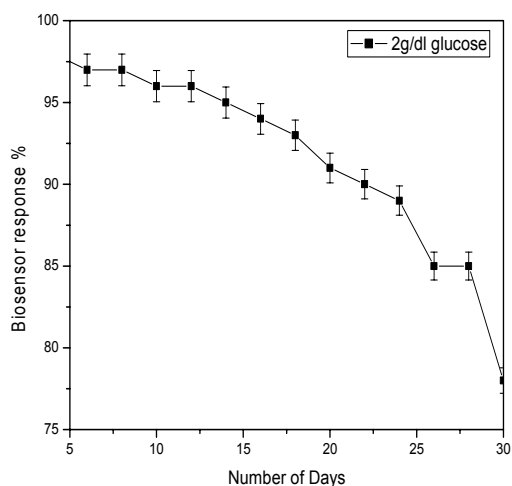

Fig. 9 Stability of biosensor.

V. CONCLUSION

Here Detachable glucose sensitive biomembrane has been developed for the measurement of glucose concentration. The current resulted from the biosensor was converted, amplified with a simple signal conditioning system and interfaced to the AT89C51 microcontroller based data acquisition system.

Excellent experimental results have been achieved for glucose detection in different fruit juices. PC is used, to display to store and to analyze the data. The results obtained were compared with the results of HPLC, and found that there is a good agreement with accuracy of $\pm 1.5\%$. In order to achieve better response for the amperometric biosensor the optimum operating conditions were investigated. The biosensor showed a stable response for twenty five days and decreasing response with 15% reduction was observed by the end of twenty seventh and twenty ninth day. The proposed system takes less time for the analysis (approximately 180 Secs), less laborious. The system can be used in food and fermentation and clinical (in-vitro) applications for the analysis of glucose concentration. The computational speed can be further improved by using dedicated processors.

ACKNOWLEDGMENT

We are thankful to Dr Ashok Shettar Principal BVB College of Engineering and Technology Hubli, India, and Dr. M.S. Thakur, Head, Biosensor group, Central Food Technological Research Institute, Mysore, India, for the encouragement given.

REFERENCES

- [1] Chaubey A., Malhotra B. D., "Mediated biosensors", *Biosensors and Bioelectronics* 17, 2002, pp. 441-456.
- [2] Guilbault G. G., 'Analytical uses of immobilized enzymes', *Mercal Dekkar*, 1984, pp. 77-160.
- [3] Wolfgang Gopel., and Peter Heiduschka., "Interface analysis in biosensor design", *Biosensors and bioelectronics* 10, 1995, pp. 853-883.
- [4] Baronus R., Ivanauskas E., Kulyas J., "Computer simulation of the response of Amperometric Biosensors in stirred and non stirred solution", *Nonlinear Analysis: Modeling and control* 8, 2003, pp. 3-18.
- [5] Rawson D. and Gaisford W., "Biosensors monitor the environment", *Control Instrum* 22, 1990, pp. 63-64.
- [6] Bilitewski U., Jager A., Ruger P., and Weise W., "Enzyme electrodes for the determination of carbohydrates in food", *Sensors and Actuators B*, 1983, pp.113-118.
- [7] Wohltjen H., "Chemical Micro sensors and Micro instrumentation", *Anal.Chem.* 56, 1984, pp. 87-103.
- [8] Wilson G.S., Thevenot D. R., (Ed: A.G.E. Cass) "Biosensors a practical approach", *Oxford University Press*, 1990, pp. 5-6.
- [9] Wilson R., and A. P.F. Turner, "Glucose oxidase an ideal enzyme", *Biosensors and Bioelectronics* 7, 1992, pp. 165-185.
- [10] Sangam V. G., and Patre B. M., "Development of computer based amperometric biosensor for the analysis of glucose concentration", In *Proc. International conference, SICE-Japan, Okayama University, Japan,2005* pp.105.
- [11] Ashok Mulchandani and Kim Rogers, "Enzyme and Microbial Biosensors – Techniques and protocols", *Human Press, Totowa, New Jersey*, 1998, pp. 199-218.
- [12] Wang J., Mulchandani A., Mulchandani P and Chen W., "Remote biosensor for in situ monitoring of organophosphate nerve agent", *Electroanalysis*, 11, 1999, pp. 866-869.
- [13] Newman J., White S., Tohill I and Turner A. P. F., "Catalytic materials, membranes and fabrication technologies suitable for the construction of amperometric biosensors", *Anal. Chem.* 67, 1995, pp. 4594-4599.
- [14] Willner I., and Riklin A., "Electrical communication between electrodes and NAD (P) - dependent enzymes using pyrroloquinoline-enzyme electrodes in a self assembled monolayer configuration: design of new

- class of amperometric biosensors”, *Anal. Chem.* 66 (9), 1994, pp. 1534-1539.
- [15] Danielsson B. “Enzyme thermistor for food analysis, Wagner. G. Guilbault (Eds)”, *Food biosensor Analysis, Marcel Dekker*, 1994, pp. 173-190.
- [16] Appleton A., Gibson T. D., and Woodward J. R., “High temperature stabilization of immobilized glucose oxidase: potential applications in biosensors”, *Sensors and Actuators, B 43*, 1997, pp. 65-69.
- [17] Gouda M. D., Kumar M.A., Thakur and Karanth N.G., “Enhancement of Operational stability of an Enzyme Biosensor, for the glucose and sucrose using protein based stabilizing agents”, *Biosensors and Bioelectronics*, 19(6), 2002, pp. 503-507.
- [18] Sarath Babu V. R., Kumar M.A., Karanth N.G., and Thakur M. S., “Stabilization of the immobilized glucose oxidase against thermal inactivation by silanization for applications”, *Biosensors and Bioelectronics*, 19 (10), 2004, pp. 132-137.
- [19] Sergio Franco. “Design with operational Amplifiers and Analog integrated Circuits”, *Tata McGraw-Hill*, 2002, pp. 60-91.
- [20] Muhammad Ali Mazidi and Janice Gillispie Mazidi, “The 8051 Microcontroller and Embedded Systems”, *Pearson education*, 2004, pp. 235-243.
- [21] Kilpatrick E. S., Ramulay A. G, Smith E. A., “ Variations in sample pH and pO₂ affect ExacTech meter glucose measurements”, *Diabet Med*, Jun11(5), 1994, pp.506-509.

V. G. Sangam is a faculty in the department of Instrumentation Engineering at the B. V. B. College of Engineering and Technology Hubli, India. He is a postgraduate in Biomedical Instrumentation. His research interest is in the area of biosensors, in particular, Instrumentation for biosensors. He is a life member of Indian Society for Technical Education, Instrument Society of India, and Biosensor Society of India.

Balasaheb M. Patre was born in Basmathnagar, India, in 1965. He received B.E and M. E. Degree in Instrumentation and Control Engineering in 1986 and 1990 respectively from Marathawada University, Aurangabad, and subsequently doctorate degree (Ph D) in Systems and Control Engineering from IIT Bombay in 1998. He has published his research work at Cambridge University UK and in Germany. He is a life member of ISTE and ISI. He is a member of IETE, IEEE, and IET. He is a reviewer for several international journals. His area of interest includes robust control, VSS, interval arithmetic applications in robust control and intelligent control etc. Presently he is working as Professor of Instrumentation Engineering at SGGGS Institute of Engineering and Technology Nanded, India.