

Analysis of Electrical Installation of a Photovoltaic Power Park in Greece

D. E. Gourgoulis, C. G. Yakinthos, M. G. Vassiliadou

Abstract—The scope of this paper is to describe a real electrical installation of renewable energy using photovoltaic cells. The displayed power grid connected network was established in 2007 at area of Northern Greece. The photovoltaic park is composed of 6120 photovoltaic cells able to deliver a total power of 1.101.600 Wp. For the transformation of DC voltage to AC voltage have been used 25 stand alone three phases inverters and for the connection at the medium voltage network of Greek Power Authority have been installed two oil immersed transformer of 630 kVA each one. Due to the wide space area of installation a specific external lightning protection system has been designed. Additionally, due to the sensitive electronics of the control and protection systems of park, surge protection, equipotent bonding and shielding were also of major importance.

Keywords—Inverter, Photovoltaic cells, Transformer.

I. INTRODUCTION

THE present application concerns photovoltaic park with power 1.280.160 Wp that is to be installed in parcel of total extent of 28.812 m² in Northern Greece. For the particular photovoltaic station has been granted authorisation of production of electric energy from the Greek Ministry of Growth and Energy [1,2]. For the study of all electrical installations the following were taken into consideration the needs for the appropriate protection of all departments of Photovoltaic Park and the Greek Regulations of electrical installations [3].

The electrical installations of the photovoltaic park have been studied with criteria such as the safety, the reliability and the low cost of operation and maintenance, the biggest possible saving of energy, the flexibility and adaptation in likely decomposition of photovoltaic cells. For the achievement of the above mentioned objectives has been selected the installation of equipment of last technology, the use of materials durable in use under unfavourable conditions of exterior environment and the path through visiting metal

Manuscript received March 31, 2008. This work was supported in part by Propondis foundation under state postdoctoral scholarship of Dr. D.E. Gourgoulis.

D. E. Gourgoulis is with the Merchant Marine Academy of Makedonia, Nea Michaniona, GR 57004 Greece (phone: 00302310855504; fax: 00302310855504; e-mail: gourgoulis@yahoo.com).

C. G. Yakinthos is with the Merchant Marine Academy of Makedonia, Nea Michaniona, GR 57004 Greece (phone: 00302310825727; fax: 00302310825741e-mail: cgyak@yahoo.com).

M. G. Vassiliadou is with the Merchant Marine Academy of Makedonia, Nea Michaniona, GR 57004 Greece (e-mail: mario@el.teithe.gr).

channels of all grids of installations in order to be easy for inspection and easy accessible.

II. FUNCTIONAL DESCRIPTION OF PV INSTALLATION

For the full operation of park have been installed 6.120 photovoltaic cells. Each photovoltaic cell has power 180 Wp with a tolerance of +10%/-5%. The cell is manufactured from mono crystalline silicon and has the following dimensions: 1318 x 994 x 46 mm, with aluminium frame and safety glass of high transparency. The connection box includes passages of bypass protection and plugs of type multi contact.

The technical characteristics are:

Nominal Power	180 Watt
Max Voltage	1000 V
Short circuit current	8,37 A
Open circuit voltage	30,0 V
Voltage in max power (MPP)	23,7 V

The technology of strings has been used. 408 chains have been installed and each chain has 15 photovoltaic cells.

Checking the total voltage of open circuit and the total voltage in the point of max power with the technical characteristics of the inverter it is realised that the total voltage of open circuit is 450 V < Input max voltage of inverter 530 V and the total voltage in max power is 355,5 V > Min operating voltage of inverter 210 V [4, 5]. These conditions satisfy the requirements of smooth collaboration in extreme meteorological parameters between inverter and strings of photovoltaic cells.

Each string has been protected both in the negative and positive pole with a 16A fuse type Diazed, nominal voltage of 600 V DC and respectively base type DII for nominal current of 25 A (Fig. 1).

For the feed-in of the strings have been installed flexible cable H07RN-7 (NMHou), DIN VDE 0282 part 4 [6], with nominal cross-section 4 mm², for both positive and the negative pole, taking into consideration functional temperature of 50°C and the biggest possible adjacency of cables and voltage drop around 1 %.

Twenty five (25) individual sub-fields "DCUVxb.1or DCUVxb.2" have been installed for the control of strings. Each individual sub-field has two inputs and each input will serve 8 or 9 strings respectively. Analytically each sub-field will serve the following strings:

DCUV1b.1 - DCUV17b.1

8 strings

DCUV1b.2 - DCUV17b.2	8 strings
DCUV18b.1 - DCUV25b.1	9 strings
DCUV18b.2 - DCUV25b.2	8 strings

Each sub-field with 8 or 9 strings, both on the negative and positive pole will be protected with fuse-break and fuse type NH, nominal current 100 A, size 00 and nominal voltage 750 V DC with respective base for fuse 160 A 3 pole (Fig. 1).

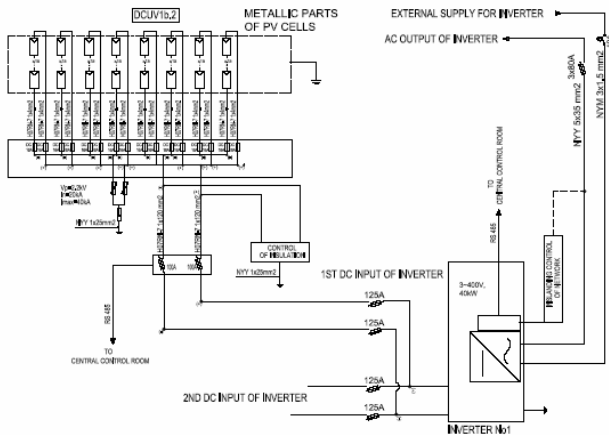

Fig. 1 Single diagram of first DC input of inverter

In each sub-field has been incorporated the possibility of controlling the insulation with departure of a RS 485 cable to the central control of installation (Fig. 1).

For the lightning protection of each sub-folder has been installed three pole (2+1) over voltage class II or class C (IEC 61312 [7], IEC 61643 [8, 9] and IEC 60364 [10]) protection, for both the positive and negative pole, provisions voltage $U_p = 2.2$ kV and withstand in impulse current around 40 kA (Fig. 1). All metallic frames of the photovoltaic cells will be grounded in the common ground of the installation.

For the connection of each sub-field, independent of the number of strings will be used flexible monopole cable type H07RN-7 (NMHou), DIN VDE 0282 part 4 [6], nominal cross-section 120 mm² and 150 mm² (depending on the distance) both for the positive and negative pole, taking in to consideration functional temperatures 50°C and the biggest possible adjacency of cables and voltage drop around 1 % (Fig. 1).

For applications in which replacement of elements under conditions of operation is not required or is acceptable short-term interruptions of operation, systems of permanent installation have been used. In order to do this the following elements are provided with prototype approved type, freely combined functional groups of elements, easily accessible connections for fast transformations and extension, free equipment with appliances and combinations of appliances for exits of cables. Wrapping from metal-sheet of steel, protection category 2 (protection insulation) IP 55 with lock and steel key, exterior installation with the form of a box situated in the floor, fully equipped, such as installation plates, holding bars,

equipment holding bars, void covers, water proof, flanges, cable connections, balancing bars, three face and AC power with rails, polyethylene bars and N bars, connectors, neutral etc. compatible with VDE 0660 [11], light grey colour RAL 7035 with incorporated protective insulation. The nominal current of each switchboard is 160 A.

Twenty five power inverters have been installed totally. Through the characteristics of the inverter it is ensured that in hyper – low voltage and high – low frequency the electric energy feed to the grid is stopped. Also the inverter characteristics ensure that the installation will be placed off the grid [12, 13] according to VDE 0126 [14] and will be interrupted the electric energy feed to the grid when a voltage interruption occurs from the side of the grid. This will ensure that no island case will be effective where neighbouring load will be feed although the Public Electric Company has stopped the power.

Each inverter will serve 2 sub-folders in general each inverter has two DC inputs and has the following characteristics:

Nominal Power (AC)	40 kW
Nominal AC Voltage	400 V
Nominal AC frequency	50 Hz
Power factor	1
AC current attenuation	<5%
Max AC current value	58 A
Night consumption	9 W
Min DC voltage feed	210 V _{DC}
Proposed PV power	40-52 kW _p
Max DC current	205 A
Max voltage open circuit	530 V
Altered voltage input	210-420 V _{DC}
Max output	94,3%
Dimensions (W x D x H)	600 x 600 x 2444,5 mm
Cooling	Biased air circulation

Inverter No 1 until Inverter No 17 serve 16 strings with a total power for each inverter 43,2 kW_p. The first and second DC input of inverters will serve 8 strings respectively.

Inverter No 18 until Inverter No 25 serve 17 strings with a total power for each inverter 45,9 kW_p. The first DC input of these inverters will serve 9 strings and the second DC input will serve 8 strings respectively.

Each DC input of the inverter with 8 or 9 strings is protected, both the negative and positive pole with a break fuse and a fuse type NH with nominal current 125 A, size 00 and nominal voltage 750 V DC and with respective base for fuse 160 A 3 pole.

AC output of the inverter is protected with a 3 phase AC break fuse and a fuse type NH with nominal current 80 A, size 000 and with respective base for fuse 160 A 3 poles.

III. FUNCTIONAL DESCRIPTION OF AC INSTALLATION

The output of inverters is 400 V AC. In order to feed the national medium voltage grid of Greek Power Authority two

oil immersed transformers have been used with the following characteristics:

Nominal Power (AC)	630 kVA
Phase	3
Incoming voltage	400 V / y
Out coming voltage	20.000 V / D
Frequency	50 Hz
Connection type	Dyn 11
Max oil Temp	60 °K
Max coil temp	65 °K
Voltage breakdown	6 %
Total losses	10.500 W

The transformer chamber must contain transformer rails with circular direction and protective railings also must have natural ventilation. The installation limits the vibrations.

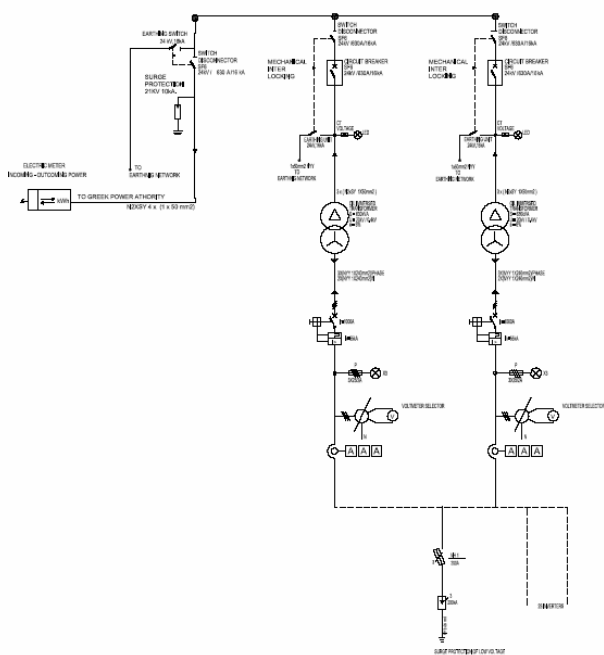

Fig. 2 Single diagram of medium voltage station

The transformer chamber must also contain the appropriate storage space, the necessary protection and safety circuits, cable passage anchor rail and bush node 30x10 mm, with 6 connection bolts M12.

The transformers will be based in an interior chamber as described by VDE 0532 [15]. The transformers can move with wheels both horizontally and vertical. The cable inputs for low and medium voltage are water proof. The input and output of cable connections are not accessible by small animals. Transformer rails HEB 140, hot galvanized, restriction of trace during melting and existing pedestal and oil sink with special use of gravel.

The produced power is provided to National Greek Power Grid Company. Two SF₆ stations for the connection of transformers have been installed with two cylindrical supplies,

and one arrival field 20 kV. The installation has the form of a single boiler room according to the National Greek Power Grid Company. The circuit breaker chamber has double base and the necessary auxiliary circuits. The connection with the Greek Power Grid Company will be as shown in the Fig. 3.

The installation takes into consideration the transfer, placement and connection of the medium voltage cable from the plot limits or from the place that the Power Grid company will indicate until the appropriate space that the voltage is measured and finally to the installation space, everything is going to be earthed using a mesh, the air spacing and the necessary telephone link for consumption telemetry according the national grid company.

The medium voltage fields are according to the international specifications. As a main break circuit is used SF₆. The provided protection grade is IP2XC. The colour is RAL 9002, thickness at least 50µm, from epoxic polyester according the standardization MG. The construction of the SM6 fields is according to ISO 9001 (Fig. 4). To every field is forecasted all the necessary mechanical connection for the personnel safety and the appropriate handling sequence.



Fig. 3 Sketch of medium voltage fields

Each field is composed from five compartments: The breaking circuit compartment, the bar compartment, the power cable connection chamber, the operational mechanism chamber and the Low voltage chamber (Fig. 4). The protection of transformer will be done with one vacuum breaker with nominal current at 630 A. The switch is provided with an inductor of 220V, 50Hz and auxiliary contacts. The incorporated electronic relay for the secondary protection is self-supplying and does not need independent source of power. The relay allocates wide beam of curves for protection against 3 phases and ground, reverse time as well as instantaneous operation. It has also electronic microprocessor

and provides protection against overcharge, short-circuit and leak to the ground, frequency control, voltage.

All spaces of electrical installations, such as the space of transformers, the space of inverters, and the space of control for the medium voltage are pointed out proportionally on the doors of entry. The plates are permanent and imperishable. The medium voltage control stations are protected by insulation layers of rubber, of width 1,5m at least and cover the whole front section. Similarly, in the spaces of medium voltage control stations are placed essential warning plates and plates of indications according to the regulation for the prevention of accidents and according to the specifications of the trade association.

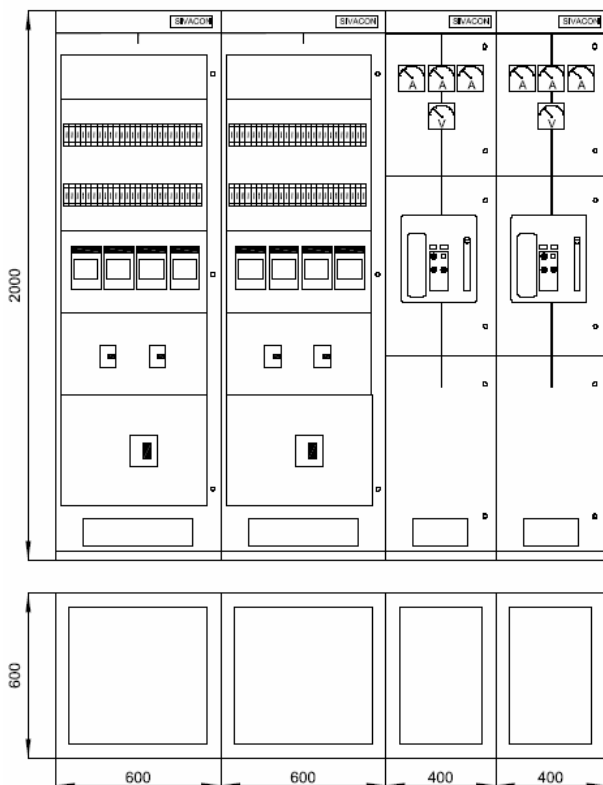

Fig. 4 Central switchboard of low voltage station for the connection of inverters and AC outputs of transformers

For the connection of medium voltage have been used four (one for reserve) pole cable type N2XSY 50 mm². The cables of medium voltage are brought in through the plates of flooring. The entry of the cables is consistent to the specifications of the enterprise of electricity. For the grounding of medium voltage station will be used according to DIN VDE 0683 [16], three-pole, fixing provision included, cross-section of cable at least 50 mm². For the connection of low voltage of transformers with the bar of low voltage of inverters have been individual cables 3x240 mm² per phase.

The central switchboard of low voltage is wrapping from sheet-metal of steel, category of protection 2 (protective

insulation) IP 30 with lock and key from steel, exterior installation in the form of cabinet, with complete equipment, as eg plates of installation, fixing bars, snails, fixing bars of appliances, covers of voids, seal ups, gaskets, entries of cables, balances, three phase and alternating current supply with rails, bars of polyethylene and bars of N, terminals, neutral conductors etc. According to VDE 0660 [11], light grey colour RAL 7035 with incorporated protective insulation. The nominal current of switchboard is 1600 A (Fig. 4).

For the lightning overcharge – over voltage protection of central switchboard has been used a 3-pole 200 kA breaker, connected with the ground via cable NYY 3 x 95 mm² and protected via fuse breaker type NH (Fig. 2).

The breadth of gate was proportional to the switches of power / of size. The appliances of measurement are placed on the door. System of sourcing of the transformer as supplying gate has been constructed with auto breaker switch of power of nominal intensity 1000 A, 55 kA equipped according to the model of equipment, including all lines of control voltage and auxiliary elements.

IV. INSTALLATION FOR GROUNDING AND LIGHTNING SYSTEM

In the whole structure is forecasted either installation of fundamental ground as much below the bases of photovoltaic cells as below the buildings of the served electrical infrastructures. So that the desirable level of protection according to DIN VDE 0100 [17] is achieved, total resistance of ground of at least 1 Ohm or smaller is required. In the building connection is placed balance of compensation of power. The pipe of compensation of power is connected to the ground of the foundation. Moreover are forecasted two grounding triangles one for the neutral of transformers and the second for the grounding of metal parts of station of medium voltage in distance bigger than 25 m one from the other. The grounding points are always accessible for control. In each sub-table is placed balance of ground. Particular attention should be given in the connection of balances to the remainder fundamental ground. Suitable endings with the corresponding connections from the internal side of foundations of deposit should be placed and placement of suitable materials for the reject of erosion should be done.

In the place of medium voltage, transformers and inverters metal structural mesh with iron sticks in-depth of 5cm is placed, for the equal balance protection of installation. In height 50cm from the flooring where the instruments above are based, will be placed circumferentially in the wall cupreous lama of ground with a cross-section of at least 50 mm² with minimal thickness of 2mm. The connections in the pillars of electric doors are placed in the ground structure. Conducting carpets of flooring should be grounded (Fig. 5).

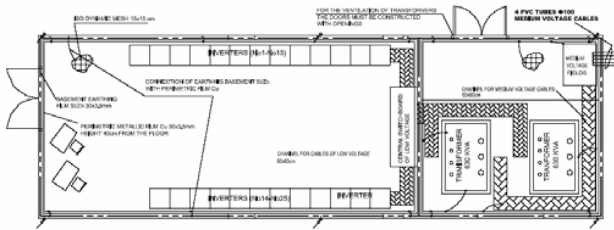

Fig. 5 General ground plan of station

In the building structures exterior lightning arrester will be placed in the form of lightning arrester structure regarding to the elements. It is a lightning arrester structure according to the category III of the new regulation on lightning arrestors DIN VDE 0185-2 [18]. The number of departments and lines of safety is calculated and installed according to the specifications DIN and VDE.

During the work on the lightning arrester structures or the structures of compensation of power particular attention is paid in the resistance of erosion of the materials used. The connections should be attended proportionally.

During the passage from the sector of ground of the foundation to the abductor attention is given so that the indicators of foundation ground that are placed on the surface stick out and are protected with chevrons of concentration.

The parts of strings are protected by a separate trap with Inox spikes $\Phi 16 \times 2000$ mm and connection in the remainder system of lightning protection of the structure. Particular attention should be given at the place of the spikes, their support in the metal frames of cells. So that the desirable level of protection according to DIN VDE 0100 [17] is achieved, total resistance of ground of at least 1 Ohm or smaller is required. The foundation ground of the base of the strings is placed in the form of closed ring. Abductors and traps have been made of St/Zn.

REFERENCES

- [1] Ministry of Development, www.ypan.gr
- [2] Hellenic Regularity Authority of Energy, www.rae.gr
- [3] Greek Public Power Authority, www.dei.gr
- [4] EA Technology, Halcrows, "Photovoltaics in Buildings: Guide to the installation of PV systems" ETSU S/P2/00355/REP/1, DTI Publications, 2002.
- [5] Article 110, "Requirements for Electrical Installations, and particularly Section 110.12" Mechanical Execution of Work, *National Electrical Code (NEC)*, 2002
- [6] DIN VDE 0282-4 BS 7919 NF C 32-102-4W.-K, "Starkstromleitungen mit vernetzter Isolierhülle für Nennspannungen bis 450/750 V Teil 4: Flexible Leitungen", 2005
- [7] IEC 61312-3, "Protection against lightning electromagnetic impulse, Part 3: Requirements of surge protective devices (SPDs)"
- [8] IEC 61643-1, "Surge protective devices connected to low-voltage power distribution systems, Part 1: Performance requirements and testing methods"
- [9] IEC 61643-12, "Surge protective devices connected to low-voltage power distribution systems, Part 12: Selection and application principles"
- [10] IEC 60364-4-44, "Electrical installations of buildings, Part 4-44: Protection for safety – Protection against voltage disturbances and electromagnetic disturbances"
- [11] DIN VDE 0660, EN 60947, "Low voltage switchgear and controlgear - Part 5: Control circuit devices and switching elements - Section 1: Electromechanical control circuit device", 2000
- [12] DIN EN 61000-4, "Electromagnetic compatibility (EMC). Testing and measurement techniques. Surge immunity test", 2006
- [13] DIN EN 61000-6, "Electromagnetic compatibility (EMC). Generic standards. Emission standard for industrial environments", 2001
- [14] VDE 0126-4-1, "Photovoltaische Einrichtungen Teil 1: Messen der photovoltaischen Strom-Spannungskennlinien (IEC 60904-1:2006)", 2007
- [15] VDE 532-224, DIN EN 50464-4, "Ölgefüllte Drehstrom-Verteilungstransformatoren 50 Hz, 50 kVA bis 2500 kVA mit einer höchsten Spannung für Betriebsmittel bis 36 kV Teil 4: Anforderungen und Prüfungen für druckbeanspruchte Wellwandkessel", 2007.
- [16] DIN VDE 0683 "Portable equipment for earthing or earthing and short-circuiting".
- [17] DIN VDE 0100 Part 410, "Erection of power installations with nominal voltages up to 1000V", 1997.
- [18] DIN VDE 0185 -2, "Risk management Assessment of risk for structures", 2002.