

On the Design of Shape Memory Alloy Locking Mechanism: A Novel Solution for Laparoscopic Ligation Process

Reza Yousefian, Michael A. Kia, and Mehrdad Hosseini Zadeh

Abstract—The blood ducts must be occluded to avoid loss of blood from vessels in laparoscopic surgeries. This paper presents a locking mechanism to be used in a ligation laparoscopic procedure (LigLAP I), as an alternative solution for a stapling procedure. Currently, stapling devices are being used to occlude vessels. Using these devices may result in some problems, including injury of bile duct, taking up a great deal of space behind the vessel, and bile leak. In this new procedure, a two-layer suture occludes a vessel. A locking mechanism is also required to hold the suture. Since there is a limited space at the device tip, a Shape Memory Alloy (SMA) actuator is used in this mechanism. Suitability for cleanroom applications, small size, and silent performance are among the advantages of SMA actuators in biomedical applications. An experimental study is conducted to examine the function of the locking mechanism. To set up the experiment, a prototype of a locking mechanism is built using nitinol, which is a nickel-titanium shape memory alloy. The locking mechanism successfully locks a polymer suture for all runs of the experiment. In addition, the effects of various surface materials on the applied pulling forces are studied. Various materials are mounted at the mechanism tip to compare the maximum pulling forces applied to the suture for each material. The results show that the various surface materials on the device tip provide large differences in the applied pulling forces.

Keywords—Laparoscopic surgery, ligation process, locking mechanism, Shape Memory Alloy (SMA) actuator.

I. INTRODUCTION

LAPAROSCOPIC or minimally invasive surgeries have several benefits in comparison to open surgeries. For instance, these benefits are shorter hospital stay and period of recovery, less pain, less scarring, and less injury to tissue. An increased tendency to perform laparoscopic surgeries is not negligible and so far there are many types of these surgeries used for different purposes. Laparoscopic cholecystectomy is one of these surgeries. Cholecystectomy is the common surgery to remove the gallbladder. This surgery is necessary when the patient has pain and the gallbladder needs to be removed because of inflammation, gallstones that block the

flow of bile, or both. There are two types of cholecystectomy procedures: open version through a large incision (traditional way) and a less invasive way, which is called laparoscopic cholecystectomy. Surgeons perform the open version when they cannot use the laparoscopic one. Unlike traditional open surgery, where tasks such as ligating vessels or tying off ductal structures are performed with ease, these tasks in laparoscopic surgery are much more difficult.

In traditional open surgery these tasks are performed by a surgeon using various types of suture materials. The surgeon manually passes the suture around the structure and then tightens it to occlude the vessel using multiple knots. Alternatively, the surgeon may consider clamping the structure first on either side, dividing it and then manually tying each.

In contrast, during laparoscopic surgeries, these tasks are considerably more difficult and rarely performed in the same manner as for open surgery. Instead, numerous devices have been developed to accommodate for the technical difficulty in both passing and tying the suture. These devices are designed to be used by one hand to occlude a vessel/structure.

Laparoscopic cholecystectomy was reported for the first time in 1987 [1] and has been used widely over the past years. The laparoscopic surgeries are mostly preferred because of the shorter period of recovery and less postoperative pain. Surgeons use a laparoscopic stapling device to ligate a vessel. The blood ducts must be occluded before the removal of the gallbladder to avoid loss of blood from vessels, which can be highly dangerous. Although laparoscopic stapling devices are popular in surgeries, there are some unusual complications and problems using these devices, including the stapling of an internal stent, injury of bile duct, and bile leak [2]. For example, bile leak occurs in between 0.5% and 3% of cases [3].

To address the problems associated with the stapling devices, we have designed a ligation procedure (LigLAP I) to occlude a vessel. During the ligation process, a two-layer suture encircles a vessel and then is tightened. Later, two sections of the suture will be melted together by a heating element. Finally, a cutting tool will cut the extra part of the suture. To tie off the suture, a locking mechanism is required to hold one side of the suture.

In this study, a locking mechanism is designed, prototyped, and evaluated. Given a limited space at the device tip, a Shape Memory Alloy (SMA) wire is used in the locking mechanism

Reza Yousefian is with the Electrical and Computer Engineering Department, Kettering University, Flint, MI 48504 USA. (E-mail: yous4999@kettering.edu)

Michael A. Kia is with the Department of surgery, Michigan State University (McLaren Regional medical Center), Flint, MI. (E-mail: michael.a.kia@gmail.com).

Mehrdad H. Zadeh is an assistant professor with the Electrical and Computer Engineering Department, Kettering University, Flint, MI 48504 USA. (E-mail: mzadeh@kettering.edu).

as an actuator. Shape Memory Alloys have many beneficial properties: high ratio of force to volume, reduction of mechanical infrastructure, and biocompatibility, just to name a few. A prototype larger than the actual size has been built to examine the function of the locking mechanism. An SMA wire has been used to move the locking mechanism peg and lock the suture by its contraction.

In Section II, the ligation device is briefly presented. Then, the background of shape memory alloys and their biomedical applications are discussed in Section III. Later, the details of the locking mechanism and experimental setup are illustrated in Sections IV and V, respectively. Furthermore, results can be found in section VI. Finally, the conclusions and future work are presented in section VII.

II. THE ELECTRO-MECHANICAL LIGATION DEVICE (LIGLAP I)

In this paper, we propose a ligation process to encircle a vessel with a suture, tighten the suture around the vessel, and force the suture to stay tightened. This process may be repeated several times to occlude all required places on the vessel, and prevent bleeding.

Currently, stapling devices are being used in ligation processes. As mentioned, the stapling devices have some disadvantages, such as taking up a great deal of space behind the vessel. To use a laparoscopic stapling device, the surgeon has to move the device tip several millimeters behind the vessel. In many cases, the required space is not available behind the vessels. This issue forces surgeons to pull on the vessel which may cause damage. The LigLAP I device will not require as much space behind the vessel. Thus, it will reduce the risk of damage. In addition, the vessel may move beyond the stapling jaw at the time of clamping [2], [3]. In this case, the vessel may not be fully occluded by the staple. The premise behind our design gets rid of that hazard.

The device is partially designed, prototyped, and examined to solve the current problems associated with the staplers. It has five main mechanisms that: a) move a suture through a channel, and encircle the vessel, b) hold the suture in place so the suture can be tightened around the vessel, c) tighten the suture, and occlude the vessel, d) tie the suture using a heating element that melts two sections of the suture together, holding the suture tight around the vessel, and e) cut and free the rest of the suture to complete the ligation process.

The main focus of this paper is on the design and experimentally verification of the locking mechanism. This mechanism holds the suture in a very limited small space at the device tip. With this in mind, a shape memory alloy actuator, which requires very small space, is used in the design of the mechanism.

The following section provides the required background for SMA actuators and its biomedical applications. Furthermore, the locking mechanism itself is presented in Section IV.

III. SHAPE MEMORY ALLOY

A. Introduction to Shape Memory Alloy

Shape Memory Alloy (SMA) is the name of metallic materials that display the Shape Memory Effect (SME). SMAs have two certain stable crystalline phases: austenite is a high temperature phase and martensite, a low temperature phase. When a material that shows this effect is deformed at low temperature, it will regain its original shape before deformation by providing heat input. The chemical composition of these two phases are exactly the same but they have different crystallographic structures, and therefore, different physical properties, such as electrical, thermal, and mechanical. Although the austenite and martensite phases have different microscopic characteristics, they do have the same macroscopic shapes.

SMAs are well known because of their properties, such as high ratio of force to volume, good chemical resistance, great capacity of damping and biocompatibility [4], [5]. A very thin SMA wire, e.g. 0.02-inch diameter nitinol wire, can apply a huge amount of force, such as 16 pounds with 5% strain [6]. SMAs have wide potential of actuating applications because of their high strain feature. Some of these applications are shape control of aircraft wing, micro-robot manipulation, and micro-system precision control [6]-[10]. Another interesting application area is actuator for minimally invasive surgery [11].

Shape memory alloy actuators have many advantages such as reduction of mechanical infrastructure, suitability for cleanroom applications, high energy density, small size, reduced number of parts compared to alternative actuators, and performing without any noise emission. SMA wires are used in most SMA-based applications, because they are easy to use for cutting, connecting, and activating electrically.

The temperatures in SMAs are usually controlled by joule heating, which is also known as resistive heating. Cooling can be implemented by natural air convection, or using appropriate cooling fluids. An important point, which must be considered, is that the resistance of SMA wire is not constant during the process of changing the temperature. The resistance is one of the 23 properties of SMA material that may be changed [12].

B. Biomedical Application of Shape Memory Alloy

SMA wires are attractive for medical devices because of the features mentioned and furthermore scalability down to several microns while having a great pulling force. Nowadays, SMA wires, specifically nitinol, are the familiar commercialize name in medical engineering area. The medical industry is attracted to minimally invasive surgeries, which needs new and smaller medical instruments [13].

The stress during the contraction of an SMA wire is approximately constant. The great mechanical behavior of SMA wires beside its biocompatibility offers many interesting opportunities in medical applications. Medical devices have a huge global market. With high revenue in this area, it is easy

to see why anything that offers new opportunities in biomedical instruments is so attractive [14]. SMA wire actuators have some disadvantages too. Low cycle speed and low energy efficiency are the main disadvantages. However, in the biomedical applications, these two are not important.

Finally, the Electrical Resistance (ER) of an SMA wire is another useful parameter, especially in biomedical applications such as our small device. This resistance changes during phase transition and provides feedback to control a process without using sensors [4], [15], [16].

In the following section, the design of the SMA-based locking mechanism is presented.

IV. LOCKING MECHANISM

As shown in Fig. 1, there is a mount (labeled as 1) with a peg connected to it. The peg of the locking mechanism (labeled as 2) has a high friction coat on the bottom of it. There is a hole near the bottom of the peg that the SMA wire is looped through. To provide contraction in the SMA wire, and therefore movement of the peg and finally holding suture under the peg, the electrical current is used to heat the SMA wire. It is easy to heat them according to the Joule effect, whereby, electric current causes enhancement in the SMA temperature following the fundamental and simple formula for Joule heating:

$$P=VI=RI^2=V^2/R$$

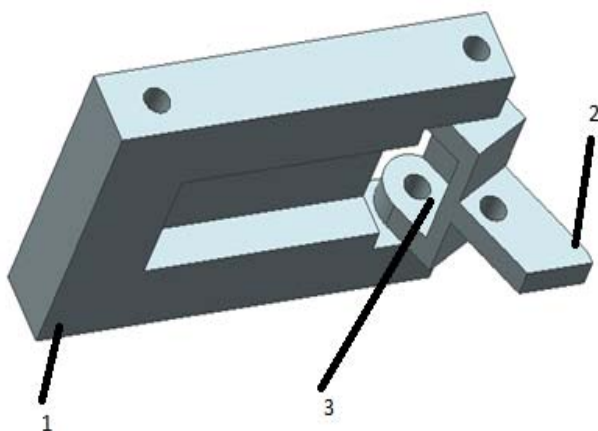

Fig. 1 Design for the locking mechanism

1.Mount, 2. Peg of locking mechanism, 3. Place of torsional spring to provide enough force to bring back the peg to its initial position

When an electric current is supplied through the wire, the peg is rotated down until it hits and locks the suture. To release the peg, a spring is placed in a channel in the mounting device and in the peg (labeled as 3). When the current is stopped in the SMA wire, the spring will force the peg back up until it hits the edge of the extruded hole in the jaw that the peg fits through.

V. EXPERIMENTAL SETUP

In order to test our locking mechanism, a prototype was made out of ABS (Acrylonitrile Butadiene Styrene) at a large scale and with modifications to the mount to allow it to hold the peg up (shown in figure 2). The mount, peg, and a spring were placed together and then the whole thing was mounted on a piece of wood. A 275 μm nitinol wire was looped through the peg and a 2-amp current has applied through it.

By providing electrical current, the temperature goes up and contraction happens in the SMA wire that leads the movement of the peg. Therefore, the suture will be locked under the peg. We have tested the amount of pulling force applied to the suture that is held in our locking mechanism using a Vernier force sensor.

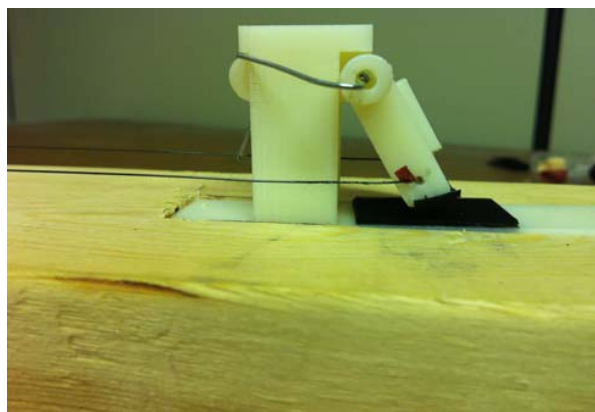

Fig. 2 The prototype of the design for the locking mechanism. The mount and peg have been modified to set up the experiment.

The full setup is shown in figure (3). A suture was placed under the peg and a current was applied to the SMA wire. The suture was then pulled by hand using a linear force gauge to record the highest force the suture was subjected to until it moved.



Fig. 3 The experimental setup to examine the locking mechanism

VI. RESULTS

The experiment was repeated for six different materials covering the peg and mount. For each material, the experiment was repeated five times. Finally, the mean and standard deviation of collected forces was calculated for each material. Below are the results showing how much force it took to move the suture while it was under the influence of the friction coefficient of different materials. There might be some errors because each of the materials had not exactly the same thickness and this could have affected the resulting force needed to move the suture.

TABLE I
AVERAGE OF MAXIMUM PULLING FORCE APPLIED TO THE SUTURE WHILE IT IS LOCKED IN THE LOCKING MECHANISM FOR DIFFERENT MATERIALS

Material	Average force (N)	Standard Deviation
Rubber band	18.63	+/- 1.6003
Buna	10.13	+/- 0.924
Neoprene	9.15	+/- 0.462
Sand paper	7.52	+/- 0.4667
Latex	7.52	+/- 0.4667
Regular paper	2.61	+/- 0.462

VII. CONCLUSION AND FUTURE WORK

A locking mechanism is presented that has to be as small as possible because of the small diameter of laparoscopic devices. As these devices are relatively long, SMA wires are suitable actuators to provide actuation at the tip of a device.

During the experiment, the locking mechanism successfully locks a polymer suture for all runs. We have been able to hold the suture in the locking mechanism while the suture is pulled up to about 18 N. This experiment is done for six materials as friction surface to examine the effects of different materials on the holding strength of the locking mechanism. The results show that the various surface materials on the device tip provide large differences in the applied pulling forces. Particularly, the rubber shows superior performance. As a result, the rubber may be the best coating for the locking peg among the six materials. It is also important to mention that several conditions play important roles in the locking process, including the initial position of the peg and the changes in the electrical current of the SMA wire, and other factors affecting surface friction.

Future work will study the effects of surface properties of various materials on the locking mechanism's ability to hold the suture. Also, the resistance of the SMA wire will be used to control the locking mechanism without using force and/or position sensor.

REFERENCES

- [1] Gallstones and Laparoscopic Cholecystectomy. NIH Consens Statement Online. 1992; Sep 14-16 10(3): 1-20
- [2] A. P. Belgaumkar, K. A. Carswell, A. Chang, A. G. Patel, "The Dangers of Using Stapling Devices for Cystic Duct Closure in Laparoscopic Cholecystectomy." *Surgical Laparoscopy, Endoscopy & Percutaneous Techniques*. Oct 2009, Vol. 19, No. 5: e194-e197
- [3] H. Massoumi, N. Kiyici, H. Hertan, "Bile leak after laparoscopic cholecystectomy." *J Clin Gastroenterol*. 2007; 41:301-305
- [4] K. Otsuka, X. Ren, "Recent developments in the research of shape-memory alloys", *Intermetallics* 7 (1999) 511-528.
- [5] Fu, Yongqing, Hejun Du, Weimin Huang, Sam Zhang, and Min Hu. "TiNi-based thin films in MEMS applications: a review." *Sensors and Actuators A: Physical* 112, no. 2 (2004): 395-408.
- [6] N. Ma, G. Song and H-J Lee, "Position control of shape memory alloy actuators with internal electrical resistance feedback using neural networks", *Smart Mater. Struct.* 13 (2004) 777-783
- [7] K. Y. Tu; T. T. Lee; C. H. Wang; C. A. Chang, "Design of fuzzy walking pattern (FWP) for a shape memory alloy (SMA) biped robot" *Systems, Man, and Cybernetics, 1998. 1998 IEEE International Conference on*, vol.4, no., pp.3266-3271 vol.4, 11-14 Oct 1998
- [8] K. Kuribayashi, "Micro SMA actuator and motion control", *Micromechatronics and Human Science, 2000. MHS 2000. Proceedings of 2000 International Symposium on*, vol., no., pp.35-42, 2000
- [9] S. Hirose, K. Ikuta, and M. Tsukamoto, "Development of a shape memory alloy actuator. Measurement of material characteristics and development of active endoscopes," *Adv. Robot.*, vol. 4, no. 1, pp. 3-27, 1995.
- [10] M. Shahinpoor and G. Wang, "Design and modelling of a novel fibrous shape memory alloy (SMA) actuator," in *Proc. SPIE, Smart Struct. Mater. 1994: Smart Struct. Intell. Syst.*, vol. 2190, pp. 730-738.
- [11] V. R. C. Kode, M. C. Cavusoglu, "Design and Characterization of a Novel Hybrid Actuator Using Shape Memory Alloy and DC Micromotor for Minimally Invasive Surgery Applications" *Mechanics, IEEE/ASME Transactions on*, vol.12, no.4, pp.455-464, Aug. 2007
- [12] J.D. Harrison, "Measurable Change Concomitant with SME Transformation", *Engineering Aspects of SMAs*, pp. 106-209, 1990.
- [13] T. Duerig, A. Pelton, D. Stockel, "An overview of nitinol medical applications", *Materials Science and Engineering A* 273-275 (1999) 149-160.
- [14] N.B. Morgan, "Medical shape memory alloy applications—the market and its products", *Materials Science and Engineering A* 378 (2004) 16-23
- [15] H. Song, E. Kubica, R. Gorbet, "Resistance modeling of SMA wire actuators", *International Workshop SMART MATERIALS, STRUCTURES & NDT in AEROSPACE*, 2011
- [16] E. Asua, J. Feutchwanger, A. García-Arribas, V. Etxebarria, "Sensorless Control of SMA-based Actuators Using Neural Networks", *Journal of Intelligent Material Systems and Structures* 2010 21: 1809