

# A Temperature-Insensitive Wide-Dynamic Range Positive/Negative Full-Wave Rectifier Based on Operational Transconductance Amplifier using Commercially Available ICs

C. Chanapromma, T. Worachak and P. Silapan

**Abstract**—This paper presents positive and negative full-wave rectifier. The proposed structure is based on OTA using commercially available ICs (LT1228). The features of the proposed circuit are that: it can rectify and amplify voltage signal with controllable output magnitude via input bias current: the output voltage is free from temperature variation. The circuit description merely consists of 1 single ended and 3 fully differential OTAs. The performance of the proposed circuit are investigated though PSpice. They show that the proposed circuit can function as positive/negative full-wave rectifier, where the voltage input wide-dynamic range from -5V to 5V. Furthermore, the output voltage is slightly dependent on the temperature variations.

**Keywords**—Full-wave rectifier, Positive/negative, OTA, Electronically controllable, Wide-dynamic range

## I. INTRODUCTION

RECTIFIER is extensively used in signal processing, signal conditional and instrumentation systems. For example, its application can be founded in AC to DC converter, peak signal detector, automatic gain control system, frequency to voltage conversion, hard disk servo loops, low-power medical device and backlight controllers [1-4]. In general, conventional voltage mode rectifier employs an operational amplifier (opamp) and a diode [5]. The output signal confronts a zero crossing distortion due to characteristic of the diode [6]. Full-wave rectifier based on operational transconductance amplifier (OTA) has been presented by Surakamponorn et al. [7]. The circuit employs only OTAs without the diode. Here, the transconductance of OTA is controlled by the current derived from the input signal to be rectified. It can be temperature-insensitive and wide-dynamic range. Unfortunately, the above circuit unable to supported for fully differential systems. Hence, Kummger et al. has been presented [8]. The circuit employs current conveyor (CC) connected with MOS and BJT transistors. In this reported rectifiers, the output ports have been both positive and negative of half/full-wave rectifiers that the reported circuit was supported for fully differential systems. However, this circuit employed complicated internal instructions due to using a large number of transistors and requiring specific bias

sources. Consequently these schemes occupy large area of monolithic chip. Koton et al. has recently been presented [9-10]. This reported was supported for fully differential systems. This is due to the property of the rectifier structure has both positive and negative output ports. Furthermore, this scheme has been simpler and suited for fabricated in IC. On the other hand, it cannot be supported more input voltage swing for linear operation, and the output magnitude cannot be electronically controllable. The proposed of this paper is to introduce a positive/negative full-wave rectifier, whose output magnitude is electronically controllable without changing a circuit topology or adding any more circuit. It can be applied in an automatic control via a microprocessor or microcontroller. The circuit construction consists of 1 single ended and 3 fully differential OTAs that the OTA was implemented by LT1228 commercially available IC. Furthermore, this proposed was supported for fully differential systems. The PSpice simulation results are also shown. They confirm that the proposed circuit provides a wide range of input voltage, temperature-insensitive and controllability of the output magnitude via input bias current and controlled current, respectively.

## II. BASIC CONCEPT OF OTA

An ideal single ended OTA is shown in Fig.1 (a). The output current of the single ended OTA is given by

$$I_o = g_m (v_i^+ - v_i^-). \quad (1)$$

An ideal fully differential OTA is illustrated in Fig.1 (b). The output currents of the fully differential OTA can be expressed as

$$I_o^+ = g_m (v_i^+ - v_i^-) \quad (2)$$

and

$$I_o^- = -g_m (v_i^+ - v_i^-) \quad (3)$$

where  $g_m$  is transconductance ( $I_B/3.87V_T$ ), implemented by LT1228 is commercially available IC.  $V_T$  is thermal voltage, which is 26 mV at room temperature. The  $g_m$  can be controlled by the bias current  $I_B$ . If  $v_i^+ - v_i^-$  is a constant DC voltage that much greater than  $3.87V_T$ , the OTA operating in saturate mode, thus the output currents becomes

$$I_o \cong I_o^+ \cong I_B \quad (4)$$

and

$$I_o^- \cong -I_B. \quad (5)$$

C. Chanapromma, T. Worachak and P. Silapan are with the Department of Electrical Computer and Industrial, Faculty of Industrial Technology, Uttaradit Rajabhat University, Muang, Uttaradit, 53000, THAILAND  
(e-mail: chaianc@uru.ac.th, thaweessakkeng@uru.ac.th, phamorn@mail.uuu.ac.th)

The fully differential OTA can be implemented by 2 single ended OTAs as shown in Fig. 2.

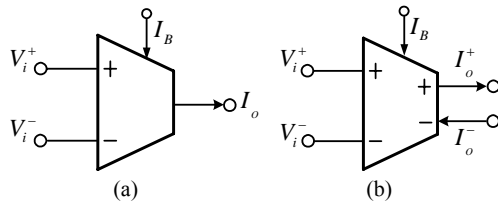

Fig. 1 The symbol of (a) the single ended OTA and (b) the fully differential OTA

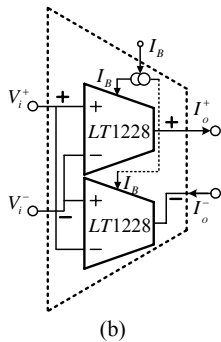

Fig. 2 The fully differential OTA based on commercially available ICs

### III. PROPOSED OF THE FULL-WAVE RECTIFIER

#### A. Positive/Negative Full-Wave Rectifier

Fig.3 shows a positive/negative full-wave rectifier, reported by Chanapromma et al. [11]. It consists of only 3 fully differential OTAs. Considering the circuit in Fig. 3, and using the fully differential OTAs properties, yields the output currents  $i_{o1}$  and  $i_{o6}$  as follows

$$i_{o1} = g_{m1}v_i, \quad (6)$$

$$i_{o2} = -g_{m1}v_i, \quad (7)$$

$$i_{o3} = \begin{cases} i_{o1} & \text{if } v_i > 0 \\ 0 & \text{if } v_i < 0 \end{cases} \quad (8)$$

$$i_{o4} = \begin{cases} -i_{o1} & \text{if } v_i > 0 \\ 0 & \text{if } v_i < 0 \end{cases}, \quad (9)$$

$$i_{o5} = \begin{cases} 0 & \text{if } v_i > 0 \\ i_{o2} & \text{if } v_i < 0 \end{cases} \quad (10)$$

and

$$i_{o6} = \begin{cases} 0 & \text{if } v_i > 0 \\ -i_{o2} & \text{if } v_i < 0 \end{cases}. \quad (11)$$

From (8)-(11),  $V_C$  is a constant DC voltage and  $V_C \gg 3.87V_T$ . The output currents  $i_{op}$  and  $i_{on}$  can be shown to be

$$i_{op} = i_{o3} + i_{o5} = \begin{cases} i_{o1} & \text{if } v_i > 0 \\ i_{o2} & \text{if } v_i < 0 \end{cases} \quad (12)$$

and

$$i_{on} = i_{o4} + i_{o6} = \begin{cases} -i_{o1} & \text{if } v_i > 0 \\ -i_{o2} & \text{if } v_i < 0 \end{cases}. \quad (13)$$

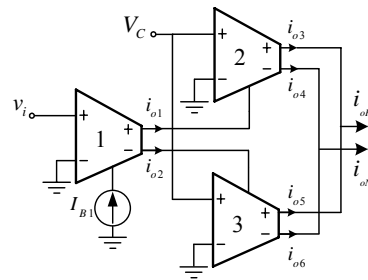

Fig. 3 Positive/negative full-wave rectifier

Substituting (6) and (7) into (12) and (13) it yields

$$i_{op} = g_{m1}|v_i| \quad (14)$$

and

$$i_{on} = -g_{m1}|v_i|. \quad (15)$$

If  $g_{m1}$  is  $I_{B1}/3.87V_T$ , the output currents in (14) and (15) will be changed to

$$i_{op} = \frac{I_{B1}}{3.87V_T}|v_i| \quad (16)$$

and

$$i_{on} = -\frac{I_{B1}}{3.87V_T}|v_i|. \quad (17)$$

It is clearly seen from (16) and (17) that the net result of the output current is the full-wave rectification of the input signal.

#### B. The proposed temperature-insensitive wide-dynamic range positive/negative full-wave rectifier

The circuit applications based on OTA, it has two limitations in the circuit design [7]. The first limitation is that the input voltage, where the differential input voltage is limited to be less than 60mV for linear operation of LT1228 commercially available IC. The second limitation is that the  $g_m$  is inversely proportional to temperature. Hence, based on the compensation scheme reported by Surakamponorn et al. [12], the proposed circuit based on OTAs is shown in Fig.4. Considering the circuit in Fig. 4,  $v_x$  can be found as

$$v_x = \frac{g_{mx}}{1 + g_{mx}R_1}v_i \quad (18)$$

and the current  $i_{o1}$  and  $i_{o2}$  can be expressed as

$$i_{o1} = g_{m1}(v_i - v_x) \quad (19)$$

and

$$i_{o2} = -g_{m1}(v_i - v_x). \quad (20)$$

Substituting (18) into (19) and (20) it yields

$$i_{o1} = \frac{g_{m1}}{1 + g_{mx}R_1}v_i \quad (21)$$

and

$$i_{o2} = -\frac{g_{m1}}{1 + g_{mx}R_1} v_i \quad (22)$$

In practical, we let  $g_{mx}R_1 \gg 1$ ,  $i_{o1}$  and  $i_{o2}$  can be approximately obtained

$$i_{o1} = \frac{g_{m1}}{g_{mx}R_1} v_i = \frac{I_{B1}}{I_{Com}R_1} v_i \quad (23)$$

and

$$i_{o2} = -\frac{g_{m1}}{g_{mx}R_1} v_i = -\frac{I_{B1}}{I_{Com}R_1} v_i \quad (24)$$

Substituting (23) and (24) into (12) and (13) it yields

$$i_{op} = \frac{I_{B1}}{I_{Com}R_1} |v_i| \quad (25)$$

and

$$i_{on} = -\frac{I_{B1}}{I_{Com}R_1} |v_i| \quad (26)$$

Consequently, the output voltage  $v_{op}$  and  $v_{on}$  can be found to be

$$v_{op} = \frac{I_{B1}R_2}{I_{Com}R_1} |v_i| \quad (27)$$

and

$$v_{on} = -\frac{I_{B1}R_2}{I_{Com}R_1} |v_i| \quad (28)$$

It can be seen from (27) and (28) that the circuit in Fig.4 can perform as positive/negative full-wave rectifier whose output magnitude can be controlled via current  $I_{B1}$  and  $I_{Com}$ , which is theoretically temperature independent.

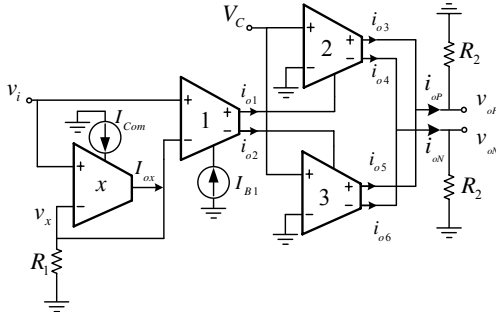

Fig. 4 The proposed temperature-insensitive wide-dynamic range positive/negative full-wave rectifier

#### IV. SIMULATION RESULTS

To prove the performances of the proposed positive/negative full-wave rectifier circuit, a PSPICE simulation was performed for examination in Fig.4. We use the conventional OTA LT1228 models from the PSpice library. The supply voltage  $V_{CC} = -V_{EE}$  were set to 15V. The OTA bias current used are  $I_{B1} = I_{Com} = 500\mu A$  and  $R_1 = R_2 = 10k\Omega$ . Fig.5 shows the DC transfer characteristic of the proposed positive/negative full-wave rectifier, the output voltage  $v_o$  versus the input voltage  $v_i$ . We can see that the high linearity can be achieved for  $v_i$  range -5V to 5V. The output voltage with input frequency 1 kHz is shown in Fig.6. Fig. 7 (a)-(b) depicts the output voltage when  $I_{B1} = 500\mu A$  for temperature variations from  $25^\circ C$ ,  $50^\circ C$  and  $100^\circ C$  of positive and negative full-wave rectifier, respectively. It

is clearly seen that the output voltage is slightly dependent on the temperature variations. Fig.8 (a)-(b) demonstrates the output voltage of positive and negative full-wave rectifier, respectively, when  $I_{B1} = 100\mu A, 250\mu A, 500\mu A$ . It can be found that the output magnitude can be electronically controlled by  $I_{B1}$ , as analyzed in (27) and (28).

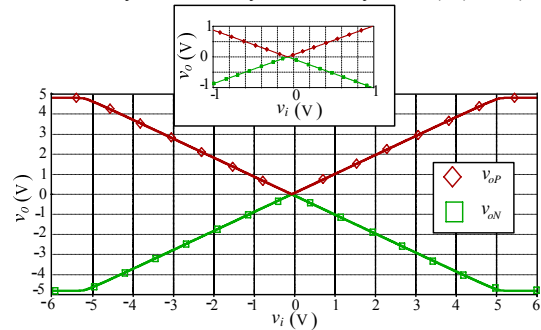

Fig. 5 DC transfer characteristic of the proposed positive/negative full-wave rectifier

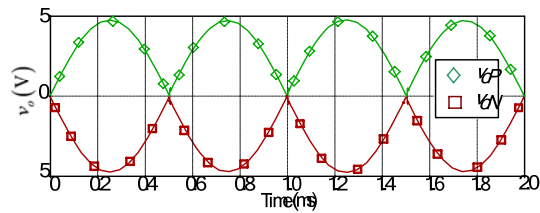
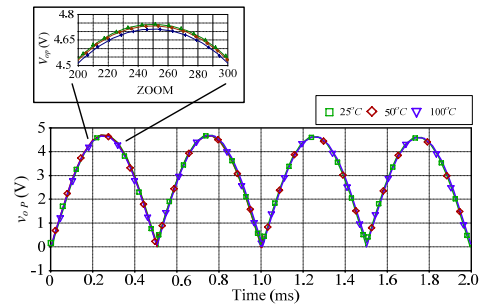
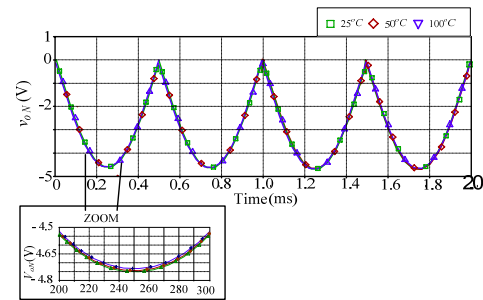

Fig. 6 The result of output voltage with input frequency 1kHz



(a) positive full-wave rectifier



(b) negative full-wave rectifier

Fig. 7 The output voltage deviations for different temperature values

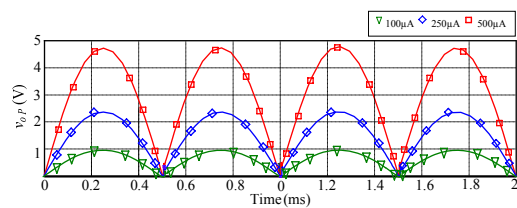

(a) positive full-wave rectifier

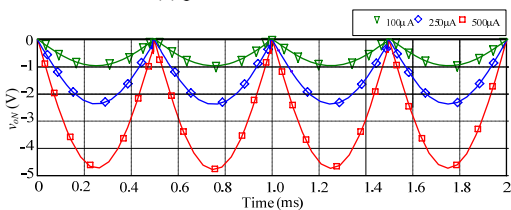

(b) negative full-wave rectifier

Fig. 8 The result of output voltage for differential  $I_{BI}$ 

### V. CONCLUSION

The positive/negative fully-wave rectifier, based on OTAs, which can rectify an input voltage with electronic controllability of output magnitude, has been reported in this paper. Circuit description merely consists of 1 sing ended and 3 fully differential OTAs. The performance of the proposed circuit have been investigated though PSPICE. They show that the proposed circuit can function as full-wave rectifier, where input voltage range  $-5V$  to  $5V$ . Furthermore, this proposed was supported for fully differential systems.

### ACKNOWLEDGMENT

This work was supported in part by a grant from Institute of Research and Development, Uttaradit Rajabhat University (URU), Thailand.

### REFERENCES

- [1] Y. Zhou, G. Huang and B. Sung, A Novel Wide-Band Envelope Detector, *2008 IEEE Radio Frequency Integrated Circuits Symposium*, 2008, pp. 219-222.
- [2] B. P. Das, N. Wasson and Y. Liu, Frequency-to-Voltage Conversion using OTA, *2010 International Conference on Electronics and Information Engineering (ICEIE 2010)*, 2010, Vol.2, pp.86-90.
- [3] M. S. J. Steyaert, et al, A CMOS Rectifier-Integrator for Amplitude Detection in Hard Disk Servo Loops, *IEEE Journal of Solid-State Circuits*, Vol. SC-30, No. 7, 1995, pp. 743-751.
- [4] A. E. Zadeh, A New High-Frequency CMOS Full-Wave Rectifier for Backlight Controllers, *51st Midwest Symposium on Circuit s and Systems*, 2008, pp.181-184.
- [5] Coughlin RF, Driscoll FF. *Operational Amplifiers and Linear Integrated Circuit*, New Jersey: Prentice Hall; 1991.
- [6] J. G. G. Stephan, Novel Precision Full-Wave Rectifier, *The 7th IEEE International Conference on Electronics, Circuits and Systems (ICECS)*, Vol. 1, 2000, pp.206-209.
- [7] C. Jongkunsitdechai, C. Fongsamut, K. Kumwachara and W. Surakamponon, Full Wave Rectifiers Operational Transconductance Amplifiers, *International Journal of Electronics and Communications (AEU)*, 2006 , pp.195- 201.
- [8] M. Kumngern and K. Dejhan, Current Conveyor-Based Versatile Precision Rectifier, *WSEAS Transaction on Circuits and Systems*, Vol. 7, 2008, pp.1070-1078
- [9] J. Koton, N. Herencsar, and K. Vrba, Minimal Configuration Precision Full-Wave Rectifier using Current and Voltage Conveyors, *IEICE Electronics Express*, Vol.7, No.12, 2010, pp.844-849.

- [10] J. Koton, N. Herencsar, and K. Vrba, Current and Voltage Conveyors in Current and Voltage-Mode Precision Full-Wave Rectifiers, *Radioengineering*, Vol.20, No.1, 2011 pp.844-849.
- [11] C. Chanapromma and K. Daoden, A CMOS Fully Differential Operational Transconductance Amplifier Operating in Sub-Threshold Region and Its Application, *International Conference on Signal Processing System (ICSPS)*, Vol.2, 2010 pp.73-77.
- [12] W. Surakamponon, V. Riewruja, K. Kumwachara, C. Surawatpunya and K. Anuntahirunrat, Temperature Insensitive Voltage-to-Current Converter and Its Applications, *IEEE Transactions on Instrumentation and Measurement*, Vol.48, 1999, pp. 1270-1277.



**C. Chanapromma** received his B. Tech. Ed. degree in electrical Engineering from the King Mongkut's Institute of Technology North Bangkok (KMUTNB) and the M.Eng. from the Mahanakorn University of Technology (MUT) Thailand, in 2006, and 2008, respectively. Presently, he has been with Department of Electrical Computer and Industrial, Faculty of Industrial Technology, Uttaradit Rajabhat University, Uttaradit, Thailand since 2009. His research interests include electronic communications, analog signal processing and analog integrated circuit.



**T. Worachak** received his B. Ind. Tech. degree in Electrical from North Eastern University (NEU), and the M. Ind. Edu. Tech. degree in Electrical Engineering from King Mongkut's university of Technology Thonburi (KMUTT), Bangkok, Thailand, in 1995 and 2007, respectively. He is currently working to Department of Computer Electrical and Industrial, Faculty of Industrial Technology, URU. His research interests include power electronic, electrical machine and signal processing.



**P. Silapan** received the B. Eng. degree in electrical engineering from Mahanakorn University of Technology, Thailand in 2002, the Master of Tech. Ed. in Electrical Technology from King Mongkut's University of Technology North Bangkok (KMUTNB) in 2005 and Ph.D. in Electrical Education from KMUTNB in 2010. Presently, he has been with Department of Electrical Computer and Industrial, Faculty of Industrial Technology, Uttaradit Rajabhat University, Uttaradit, Thailand since 2006. His research interests include electronic communications, analog signal processing and analog integrated circuit.