

# Simulation and Parameterization by the Finite element Method of a C Shape Delectromagnet for Application in the Characterization of Magnetic Properties of Materials

A. A Velásquez, J.Baena

**Abstract**—This article presents the simulation, parameterization and optimization of an electromagnet with the C-shaped configuration, intended for the study of magnetic properties of materials. The electromagnet studied consists of a C-shaped yoke, which provides self-shielding for minimizing losses of magnetic flux density, two poles of high magnetic permeability and power coils wound on the poles. The main physical variable studied was the static magnetic flux density in a column within the gap between the poles, with  $4\text{cm}^2$  of square cross section and a length of 5cm, seeking a suitable set of parameters that allow us to achieve a uniform magnetic flux density of  $1 \times 10^4$  Gauss values above this in the column, when the system operates at room temperature and with a current consumption not exceeding 5A.

By means of a magnetostatic analysis by the finite element method, the magnetic flux density and the distribution of the magnetic field lines were visualized and quantified. From the results obtained by simulating an initial configuration of electromagnet, a structural optimization of the geometry of the adjustable caps for the ends of the poles was performed. The magnetic permeability effect of the soft magnetic materials used in the poles system, such as low-carbon steel (0.08% C), Permalloy (45% Ni, 54.7% Fe) and Mu-metal (21.2% Fe, 78.5% Ni), was also evaluated. The intensity and uniformity of the magnetic field in the gap showed a high dependence with the factors described above. The magnetic field achieved in the column was uniform and its magnitude ranged between  $1.5 \times 10^4$  Gauss and  $1.9 \times 10^4$  Gauss according to the material of the pole used, with the possibility of increasing the magnetic field by choosing a suitable geometry of the cap, introducing a cooling system for the coils and adjusting the spacing between the poles. This makes the device a versatile and scalable tool to generate the magnetic field necessary to perform magnetic characterization of materials by techniques such as vibrating sample magnetometry (VSM), Hall-effect, Kerr-effect magnetometry, among others. Additionally, a CAD design of the modules of the electromagnet is presented in order to facilitate the construction and scaling of the physical device.

**Keywords**—Electromagnet, Finite Elements Method, Magnetostatic, Magnetometry, Modeling.

A. A Velásquez is with the Departamento de Ciencias Básicas, Grupo Electromagnetismo Aplicado, Universidad EAFIT, Medellín, Colombia, Cra 49 N°7 Sur -50 (phone: (57)(4)2619500 Ext 9046; fax: (57)(4)4489500; (e-mail: avelas26@eafit.edu.co).

J.Baena is with the Departamento de Ciencias Básicas, Grupo Electromagnetismo Aplicado, Universidad EAFIT, Medellín, Colombia, Cra 49 N°7 Sur -50 (e-mail: jbaenaro@eafit.edu.co).

## I. INTRODUCTION

THE measurement of magnetic properties of micro- and nano-structured materials, soft and hard magnetic materials in bulk, and thin films, are of great importance in different fields of research in physics as well as in technological applications [1], [2]. These materials are used in devices for magnetic storage, magnetic force microscopes (MFM), magnetic sensors, spintronic devices, magnetic fluids, electric machines, among others [3], [4].

To measure magnetic properties, such as saturation magnetization, remanent magnetization, coercive field, magnetic anisotropy and maximum energy product BH of magnetic materials, measurements of hysteresis loops are made. The technique more used to make the above measurements is the vibrating sample magnetometry (VSM), which is based on the electromotive force (EMF) induced in sensing coils that collect changes in the magnetic flux produced by variations in the magnetization of the sample with the applied field [5]. In the vibrating sample magnetometer a homogeneous and uniform magnetic field with intensity on the scale of a  $1 \times 10^4$  Gauss, is applied in a region of interest, which usually comprises the spacing between the two poles of the electromagnet, where the sample is placed. At the same time, the sample axially vibrates while it is permeated by the magnetic field. A pick up coil system senses the changes in the magnetic flux produced by variations in the magnetization of the sample by the effect of the applied magnetic field.

This study aims to design a C-shaped electromagnet for application in magnetometry experiments, supported by computer aided design tools. The key point for generating a magnetic homogeneous field in the poles gap lies in the optimal design of the system of poles and the yoke, in order to obtain a suitable concentration of magnetic field lines in the region of interest. In our system the interest region is a column with  $4\text{cm}^2$  square cross section and 5cm length, where the magnetic field must be uniform and its magnitude must range between  $1 \times 10^4$  Gauss and  $1.5 \times 10^4$  Gauss. These conditions are desired when the system operates at room temperature and its maximum current consumption is 5A, however higher currents could be supported if a cooling water system is used.

The implementation of this electromagnetic system is an option versatile and of low cost, useful to study of magnetic materials by experimental techniques where intense and uniform magnetic fields are required, such as Kerr-effect magnetometry, magnetoresistance (MR), Hall-effect, vibrating sample magnetometry, Mössbauer spectroscopy with the external magnetic field, among others.

## II. THE PROBLEM

### A. Geometric Modeling

As previously mentioned, the main purpose of the design was to ensure uniformity and a suitable intensity of the magnetic field in the region between poles, which is called the gap.

To do this, several possible configurations were studied, taking into account factors such as the cost-benefit ratio, machinability of the device, efficiency, power consumption, heat dissipation and accessibility of materials in the local market.

This process was addressed in five steps: a) configuration of the initial parameters; b) choosing the shape of the yoke; c) design of the cap; d) adjust of the angle of the caps; and e) optimization of the geometry. In each one of these steps, simulations were performed, which allowed us to observe the distribution and value of the magnetic field, as well as the maximum density of the field achievable in the gap.

Therefore, we did a literature review of several models that met the previously cited specifications, establishing that commercial reference 3470, developed by GMW Associates, is a good starting point for the C-shaped configuration desired.

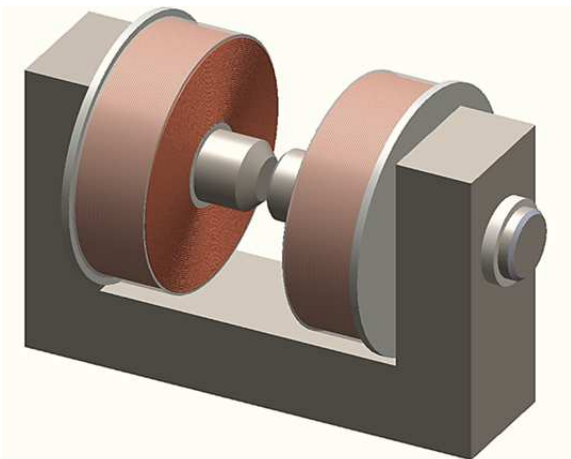

Fig. 1 Isometric view of the final model implemented in Solid Works

The electromagnet also has two coils wound on each pole, with 950 turns of copper wire. According to the standard American Wire Gauge (AWG) we used the 17-gauge wire, which has 0.115cm in diameter. Our design contains 53 coil layers connected in parallel in order to reduce the heat dissipation generated when the maximum current of 5A is used.

For our future applications with VSM experiments, the electromagnet will be turned on in cycles of 2 min and turned off in cycles of 4 min, operating at full power. If the sample requires many hysteresis loops, it will be necessary to turn on the water cooling system in order to keep a constant temperature in the power coils and poles. For this reason, we modeled a system of concentric cylinders that includes the poles and the yoke, through which pressurized water flows with an approximate flow rate of 1 Liter/min. Fig 2. shows the surveying generated by the CAD (Computer-Assisted Design) software with the geometric parameters.

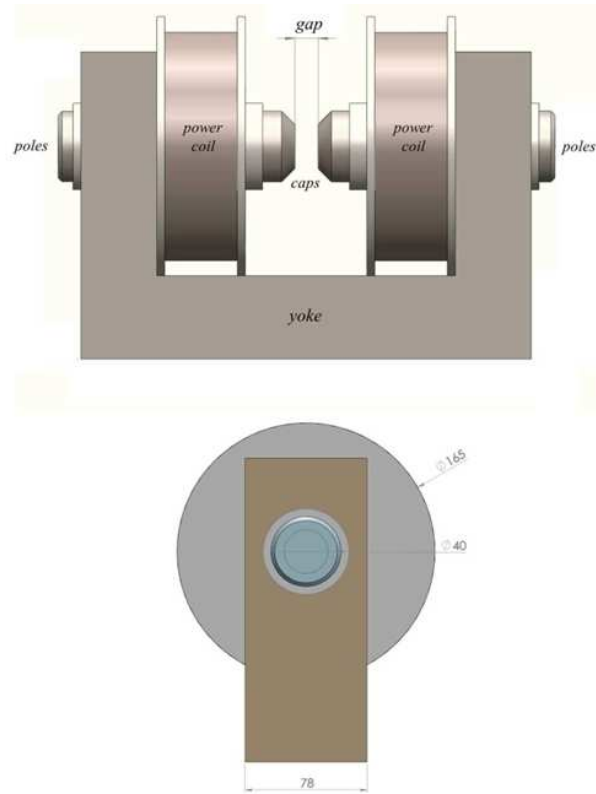

Fig. 2 Lateral and front views of the models, showing the main dimensions -in millimeters-of the assembly

### B. Preprocessing Considerations

We concentrated on the design of the electromagnet, considering that by optimizing the yoke and the poles, energy efficiency would improve, making the magnetic field generation system more attractive for large-scale implementations and achieving the evaluation of the viability and feasibility of the proposed design; for this reason, the following considerations were posed for simulation by the method of magnetostatic finite elements:

- The ferromagnetic material is linear, isotropic, homogeneous and stresses associated with machining are neglected; consequently, its magnetic permeability is constant [7].
- Although in practice this is not always true, there is a good approximation when working in the linear range of materials, before the saturation state.

- In the magnetostatic analysis of the problem, only two dimensions (height and width) were considered, since they contain the distribution of the magnetic field, which does not change throughout the third dimension (depth), if this is assumed to be uniform.
- The effect of the third dimension is significant when the configuration studied possesses different thicknesses or when it is comparable to that of the other two dimensions [7].
- The idea of including caps in the pole system is related to the need to increase the magnetic flux density and uniformity.

In addition, we evaluated the most appropriate materials to construct the device. For the system of poles and the yoke, we sought a magnetically soft material, with high magnetic permeability and easy machining to prevent mechanical stresses in the material, since these produce changes in the orientation of the magnetization easy axis.

We made simulations with Low-carbon steel (99.02% Fe, 0.08% C), Permalloy (45% Fe, 54.7% Ni) and Mu-Metal (21.2% Fe, 78.5% Ni). Table 1. shows the final specifications of the design and the parameters of the magnetic circuit used in the simulation.

The reduction of the angle in the caps was obtained from a geometric optimization, using the ANSYS software, which showed that the 70° angle gives the best intensity and homogeneity of the magnetic field in the gap.

TABLE I  
DESIGN SPECIFICATIONS

General Specifications of the C-Shaped Electromagnet	
<i>Cores</i>	
Pole diameters	4,5 cm
Minimum diameter of the cap	2,225cm
Minimum distance between the poles (gap)	1cm
Material	Low-carbon steel
<i>Coils</i>	
22°C Maximum current	5A
Number of turns	950
Number of coil layers	53
Wire gauge (AWG)	0.115cm

The spatial distribution of the magnetic field is governed by the Poisson's equation, which is a second order differential equation that can be solved by different methods: graphic, experimental, analytical and numerical [8].

In this study, we used the finite element numerical method, which, during the pre-processing, subdivides the geometry in triangular regions known as elements and from these and the boundary conditions, determines the magnetic potential in the vertices of each element [7]. The method ends with the post-processing and graphically representing the solution with a gradient of colors associated with the minimum and maximum values that the intensity field takes at each point.

The physical variable is the magnetic field constant in time and is calculated through magnetic power, which is governed by Poisson's equation, where the sources are the density of the circulating currents in the power coils.

The method used in this work is the finite element method (FEM), described by D. Rairán, C. Aguirre, and J. J. Castañeda [9].

The problem proposed belongs to a problem of boundary values, in which the solution of an elliptical-differential equation is sought, such as Poisson's equation (1), within a bounded region, in this case bi-dimensional, so that the magnetic vectorial potential  $A$  takes the prescribed values in the boundary of the region. The essence of this method lies in approximating potential  $A$  within each element in a standard manner, and then interrelating the potential distributions of the elements to impose the condition so that it is continuous through the boundaries of the elements. [10]

In the Poisson equation:

$$\nabla^2 \vec{A} = -\mu \vec{J} \quad (1)$$

$\vec{A}$  is the vector potential,  $\mu$  is the magnetic permeability and  $\vec{J}$  is the current density.

The accuracy of the solution will depend on the "weight function" selected as the likely function. Galerkin's Method was used to perform this approximation.

Through the application of integration by parts, the order of the differential equation is reduced and passes to order one. This is the main advantage of Galerkin's Method, since it reduces the degree of the differential equation. [9]

If  $\Omega$  is the space domain and  $\Gamma$  is the boundary condition domain, we have the Galerkin equation:

$$\int_{\Omega} \omega f(x) d\Omega + \int_{\Gamma} \omega g(x) d\Gamma = 0 \quad (2)$$

The first term of (2) describes the internal behavior of the observed region (domain), whether it be linear, superficial or volumetric. The second term describes the boundaries of the region or the boundary zone.

The weak formulation of the Poisson equation by Galerkin's Method is presented in (3):

$$\omega \left[ \iint_{\Omega} \frac{\partial}{\partial x} \left( \frac{1}{\mu} \frac{d\vec{A}}{dx} \right) dx dy + \iint_{\Omega} \frac{\partial}{\partial y} \left( \frac{1}{\mu} \frac{d\vec{A}}{dy} \right) dx dy + \iint_{\Omega} \vec{J} dx dy \right] = 0 \quad (3)$$

In this case, the software uses infinite-boundary conditions, as shown in Fig 3. There are two types boundary conditions:

- Dirichlet's condition: a constant value of potential is assigned to the boundary of the region.
- Neumann's condition: a perpendicular direction is assigned to the field lines that pass through the boundary of the region; that is, a null value is assigned to the normal derivative [11].

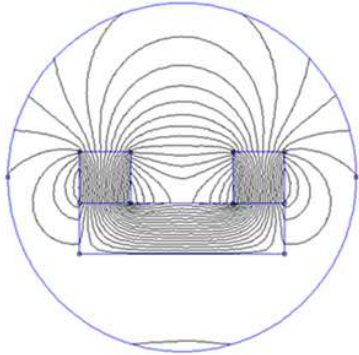

Fig. 3 Visualization of the applied boundary conditions, shown in a permanent magnet

Given the geometric configuration presented in Fig 2. we determine the value of the magnetic vectorial potential in the spacing of the poles with a cross sectional area of 4cm<sup>2</sup>, a current intensity of five 5 A and a relative permeability of 1000; that is,  $\mu = 4\pi \times 10^{-6} \text{H/cm}$ . Due to the symmetry of the geometry, the distribution of the magnetic field is equal in all quadrants, which is meshed in the ANSYS software, as shown in Fig 4.

To generate a uniform mesh, it is desired that it be constant throughout the geometry, however it could be very advantageous to have different element sizes in function of the region in which they are located. When the geometry is more complex (for example, in the end of the poles, due to rounding), it would be necessary to resolve with smaller elements (geometric adaptability). A uniform mesh with these small elements will need many nodes, of which not all will help in the same way to improve the accuracy of the result. [9][10].

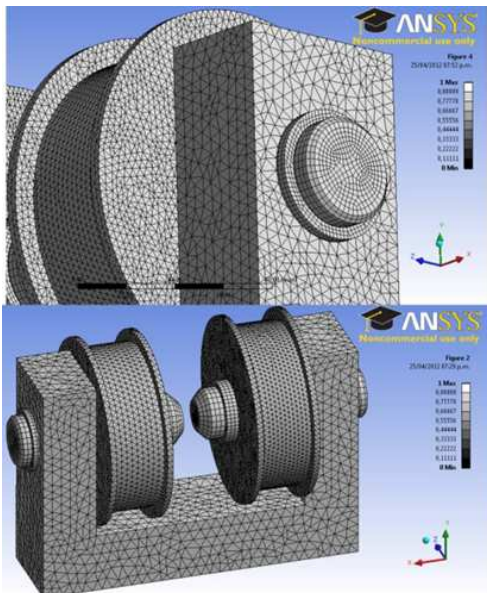

Fig.4 Triangulation generated by the multi-physics simulation package

We performed a triangulation of thousands of elements, only adding computational cost [9], looking for a hyper-fine mesh to achieve an acceptable convergence time. Future studies may include the handling of non-linearities in the materials, temporal variation of the physical parameters, handling of elements other than triangular, and the handling of the third dimension.

#### IV. ANALYSIS OF THE RESULTS

Fig 5 shows the results generated by the ANSYS software. Because the software offers the possibility of using any number of elements, we decided to add triangular elements that allow observing the behavior of the magnetic potential more fully.

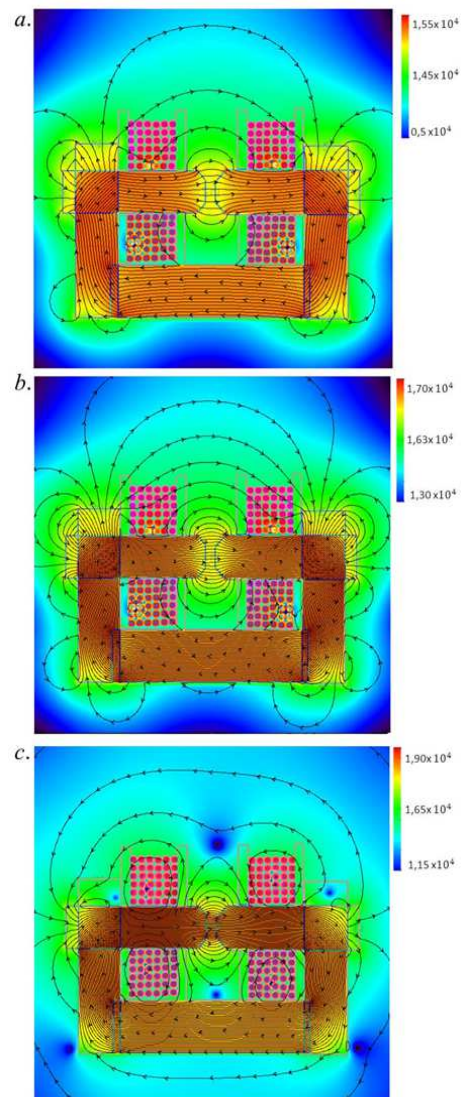

Fig. 5 Magnetostatic-analysis results. a) Simulation with Low-carbon steel; b) Simulation with Permalloy (45% Fe, 54.7% Ni); c) Simulation with Mu-Metal (21.2% Fe, 78.5% Ni). The increase in the density of the lines of the magnetic field is observed as the magnetic permeability of the materials increases

In the contour regions mapped by the colors, the magnetic-potential distribution and the lines of the magnetic field are shown. It may also be observed that this configuration can achieve up to  $1.9 \times 10^4$  Gauss (Mu-Metal), giving a wide range of possibilities for applications in magnetometry depending on the magnetic permeability of the pole used.

TABLE II  
MAXIMUM FIELD RESULTS

Material	Relative Magnetic Permeability	Magnetic Field in the gap
a) Low-carbon steel ( 0.08% C)	1.500	$1.55 \times 10^4$ Gauss
b) Permalloy (45% Ni, 54.7% Fe)	4.000	$1.70 \times 10^4$ Gauss
c) Mu-metal (21,2% Fe, 78,5%Ni)	20.000	$1.90 \times 10^4$ Gauss

Table II shows the magnetostatic analysis results in the gap, which show that, for the same C-shaped configuration, with the same spacing between the poles and the same caps, the maximum field achieved is  $1.9 \times 10^4$  Gauss with Mu-Metal, the magnetic field generated by the same configuration with Permalloy is  $1.7 \times 10^4$  Gauss, and the field in the gap region generated with 1006 Low-carbon steel is  $1.55 \times 10^4$  Gauss.

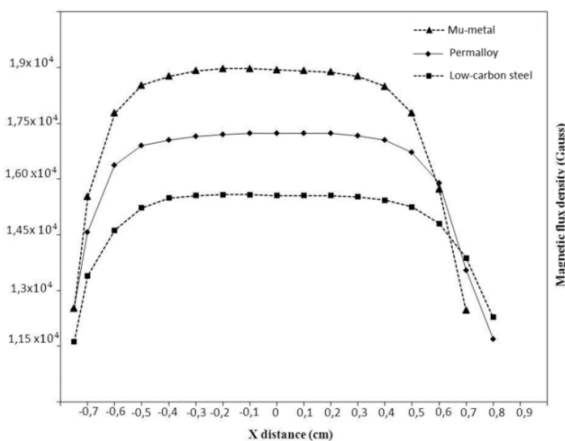

Fig. 6 Maximum-field result ( $1.55 \times 10^4$  Gauss) achieved by Low-carbon steel

Fig 6 shows the magnetostatic analysis results, being the maximum magnetic field achieved by Mu-metal. The most affordable option for us is the configuration C-shaped with Low-carbon steel, because of its mechanical properties, low cost, and the magnetic field achieved for the proposed applications.

## V. CONCLUSION

A first prototype of an electromagnet was designed, modeled and simulated; it achieves magnetic fields close to  $1 \times 10^4$  Gauss in the gap region, with the possibility of increasing the magnetic field depending on the cap geometry, material and dimensions of the poles and yoke and the spacing between the poles.

By the finite-element method, we were able to optimize the reduction of the cap angle, which increased the uniformity of the field and its intensity in the gap region.

These results show that the design of magnetic circuits using the Finite Element Method (FEM) is a good choice. Using limited data (current density, configuration of the poles and yoke, boundary conditions and permeability); the distribution of the magnetic field may be found.

We observed the effect of the magnetic permeability of the poles, yoke and caps in the magnitude and direction of the magnetic field achieved.

We evaluated design criteria and the engineering requirements that permitted a viable prototype for manufacturing, as well as a portable design, with a range of magnetic field that can serve multiple applications, among them magnetic characterization of materials.

For future work, we propose a thermal simulation that will allow establishing the relationship between the field that is obtained in the gap region for different temperatures of the poles, yoke and power coils.

## ACKNOWLEDGMENT

Special acknowledgment to the Educación Suiza Foundation and the Universidad EAFIT Scholarship Program for their unconditional support in every aspect which was essential for the development of this work.

Special thanks to Nicolás Guarín Zapata, Computational Mechanics Specialist, for his valuable contributions in the numerical solution by the Finite Element Method.

Similarly, special thanks to the entire laboratory staff in EAFIT University's Physics Engineering Department, for providing the tool necessary to implement this project.

## REFERENCES

- [1] D. Antonio, H. Pastoriza, "Highly sensitive magnetometers deployed with Micro-mechanical oscillators", Doctoral Thesis, Balseiro Institute, pp. 3-4, November 2009.
- [2] T. Furubayashi, "Magnetite films prepared by reactive evaporation", Journal of Magnetism and Magnetic Materials, pp. 272-273, 2004.
- [3] X. Hu, M. Xu, X. Cui, S. Zhang, "Room-temperature magnetoresistance effects of Ag-added  $\text{Fe}_3\text{O}_4$  films with single-domains grains", Solid State Communications, Vol 142 pp. 595-596, December 2007.
- [4] H. Zhu, D. Yang, L. Zhu, "Hydrothermal growth and characterization of magnetite ( $\text{Fe}_3\text{O}_4$ ) thin films", Surfaces & Coating technology, Vol 201, pp. 5870-5871, December 2006.
- [5] F. D. Saconne, "Design of a biaxial and low-cost vibrating sample magnetometer (VSM)", Anales AFA, vol. 17, pp. 297, 2005.
- [6] J. D. Rairán, C. Aguirre, and J. J. Castañeda. "Electromagnet design by finite element method", Tecnura Magazine, Vol 17, pp 38-40, December 2005.
- [7] Z. Markus. "Power Dissipation and Magnetic Forces on Maglev Rebars", IEEE transaction on Magnetics, Vol 33, pp. 1021-1035, March 1997.
- [8] J. D. Rairán, C. Aguirre, and J. J. Castañeda. "Application of finite element method to the solution of invariant time second order differential equation.", unpublished.
- [9] S. J. Amodeo. "Electromagnetic Systems Modeling by Finite Element Method", Argentina magazine of student works, vol1, p.p 7-8. February 2006.
- [10] M. V. K. Chary and P. P. Silvester. "Finite element in electrical and magnetic field problems." John Wiley & Sons, Inc. New York. United States of America.