

Analysis of Hollow Rollers Implementation in Flexible Manufacturing of Large Bearings

S. Barabas, A.Fota.

Abstract—In this paper is study the possibility of successfully implementing of hollow roller concept in order to minimize inertial mass of the large bearings, with major results in diminution of the material consumption, increasing of power efficiency (in wind power station area), increasing of the durability and life duration of the large bearings systems, noise reduction in working, resistance to vibrations, an important diminution of losses by abrasion and reduction of the working temperature. In this purpose was developed an original solution through which are reduced mass, inertial forces and moments of large bearings by using of hollow rollers. The research was made by using the method of finite element analysis applied on software type Solidworks - Nastran. Also, is study the possibility of rapidly changing the manufacturing system of solid and hollow cylindrical rollers.

Keywords—Large bearings, Von Mises stress, hollow rollers, flexible manufacturing system

I. INTRODUCTION

IMPLEMENTATION of large bearings with hollow rollers in wind turbine system lead to significant gains in constant power plant operation simplifying management of inertial forces. The mathematical model has been implemented in an algorithm, by which it is possible to study Von Mises stress distribution for various models of hollow rollers. The finite element method (FEM) is developed with Solidworks - Nastran software, [12]. Reduction of inertial mass of the large bearings, used in wind power industry lead to important economy of material and energy income, bring a serious contribution in energy sustentation at constant level, in various conditions of primary source. The objective of the paper is to show a solution for increase the large bearings durability using weight reduction in large bearings construction, accomplished by the use of hollow rollers. The bearing life is strongly influenced by the stress and its reduction is conditioned by the specifics of the rollers geometry. Utilization of hollow rollers has mainly been to achieve high speed, accuracy and low maintenance, becoming a necessary element in increased request of the market constituting a useful step to define new technologies and high quality products. With increasing the power of wind The control of high speed turbines also increases their size and inertial mass so, leading to increase the speed of the starting.

S. Barabas is PhD. Engineer at "Transilvania" University, Brasov, Romania, Faculty of Technological Engineering and Industrial Management, Department of Economic Engineering and Production Systems; (e-mail: ab.sorin@gmail.com).

A. Fota is Professor PhD. Engineer at "Transilvania" University, Brasov, Romania, Faculty of Technological Engineering and Industrial Management, Department of Economic Engineering and Production Systems; (e-mail: fota.a@unitbv.ro)

is more difficult and the reduction of the inertial forces becomes mandatory. The two problems are the sustainability of the hollow rollers and flexible changing production.

The researches will be also extended in the field of Flexible Manufacturing Systems (FMS) management and control in real environment. The implementing of a FMS in an integrate fabrication system, represents an important result, which leads to the optimization of the entire material and informational flux of the enterprise. The flexible manufacturing system is the manufacturing system with a new behavior, as a response to market demands: diversity, production series, and product complexity, time in service, delivery times, cost and quality.[14]

II. DISTRIBUTION OF FORCES ON CYLINDRICAL ROLLER BEARINGS

The forces distribution depends by the role playing of rollers, forces and moments acting them are centrifugal, inertia, friction and hydrodynamic forces, [8]

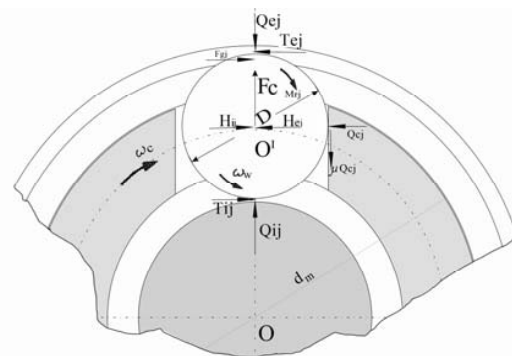

Fig. 1 The distribution of forces on cylindrical roller bearing

T_{ij} -tangential friction force between the roller and the inner ring;

T_{ej} -tangential friction force between the roller and the outer ring;

H_{ij}, H_{ej} -hydrodynamic forces;

F_c -centrifugal force;

Q_{ij}, Q_{ej} -normal forces of pressure;

$Q_{ej}, \mu Q_{ej}$ -normal forces of pressure and friction force between the roller and cage;

F_{gj} -friction force between the roller and the guide shoulder;

M_{rj} -moment resistant to the spin roller;

ω_w -rotational speed of the roller;

ω_c -rotational speed of the bearing;

d_m -disposal diameter.

$$m = \rho \frac{\pi D^2}{4} L \quad (1)$$

where: m -mass of roller; D -diameter of roller; L -length of roller.

The roller inertia is:

$$J_r = \frac{\rho \pi D^2 L d_m^2}{16} \quad (2)$$

The equations of equilibrium (Fig.1) for the forces will be:

$$H_{ij} + T_{ij} - H_{ej} - T_{ej} + F_{gj} - Q_{cj} = 0 \quad (3)$$

$$Q_{ij} + F_c - Q_{ej} - \mu Q_{ci} = 0 \quad (4)$$

$$\frac{(T_{ij} + T_{ej} - \mu Q_{cj})D}{2} - M_{rj} = J_r \frac{d\omega_{wj}}{dt} \quad (5)$$

III. THE INERTIA IN WIND TURBINE SYSTEM

The energy of a wind turbine is the sum of the kinetic energy of the rotor, the gearbox and the generator (Fig.2). The inertia of the turbine blades will be much higher than that of the electrical generator. The latter will have a much higher rotational speed however, which will also result in a large amount of kinetic energy. The inertia J of a body is:

$$J = \sum m_i \cdot r_i^2 \quad (6)$$

where r_i is the radial distance from the inertia axis to the particle of mass m_i and the summation is taken over all particles of the body. The total moment of inertia [1] for a three-bladed turbine is given by:

$$J = 3m_b r^2 \quad (7)$$

where m_b is the mass of one blade, and r is the radius of weight center of blades. For a typical 2MW wind turbine the total mass of the rotor is about 40t. [13]

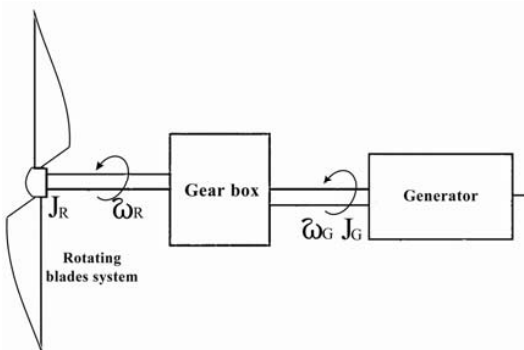

Fig. 2 Dynamic scheme of a wind turbine system

Can write the equations of equilibrium [2]:

$$T_R - T_{CV1} = J_R \frac{d\omega_R}{dt} + B_R \omega_R \quad (8)$$

$$T_{CV2} - T_G = J_G \frac{d\omega_G}{dt} + B_G \omega_G \quad (9)$$

where:

B_R and B_G are the constant friction in the rotor and generator system;

T_R is the rotor torque;

T_{CV1} is the gear box torque to the start;

T_{CV2} is the gear box torque to the end;

T_G is the generator torque to the end;

J_R is the moment of inertia of the rotor;

J_G is the moment of inertia of the generator;

ω_R is the rotational speed of the main shaft;

ω_G is the rotational speed to the start of generator.

From (8) result:

$$\frac{d\omega_R}{dt} = \frac{T_R - T_{CV1} - B_R \omega_R}{J_R} \quad (10)$$

Relation (10) leads to the obvious conclusion: importance of decreasing moment of inertia of rotor hence its inertial mass, will lead directly to increase rotational speed of main shaft so will enable faster start at low speed wind of power plant.

Because of the large moment of inertia of the rotor, the main design challenges include the starting, the speed control during the power producing operation, and stopping the turbine when required. The main issue in the tower design is the vibration appearance. The tower vibration decrease with reduction of inertial mass.

One of the ways we can reduce moment of inertia is given by reducing weight of bearings positioned in blades rotational system. For this, we propose the use of bearings with hollow rollers.

IV. FINITE ELEMENT ANALYSIS FOR ROLLERS

Practicability of hollow rollers in construction of large bearings was examined for a material type aiming deep carburization effect. The used material is allied steel: 15NiCr13. Roller dimensions are: $L=160\text{mm}$, $R=40\text{mm}$, $r=30\text{mm}$, size corresponding approximately with 60% hollowness [3]. Solid and hollow rollers have been modeled.

The finite element software Solidworks - Nastran is used to determine the values of Von Mises stress. Model of this simulation validate form of the roller and give to the researchers the possibility to choose the appropriate design. The analysis model is presented in Figure 3 [4].

The roller profile has a significant influence on the distribution of the contact stress and Von Mises stress [5], hence, on the bearing load-carrying capacity and life. The best profile of the contact geometry is logarithmic [6]. The

advantages of the logarithmic profile have been largely confirmed in research applications.

A recent study also suggested that an crowned profile would be better profile, which can be used to eliminate stress concentration [7]. In both cases manufacturing precision is very high and affect the cost of the bearing. If the manufacture of the roller surface is not accurate enough, the uniform stress distribution may not be achieved, because the edge-stresses cannot be eliminated, as expected.

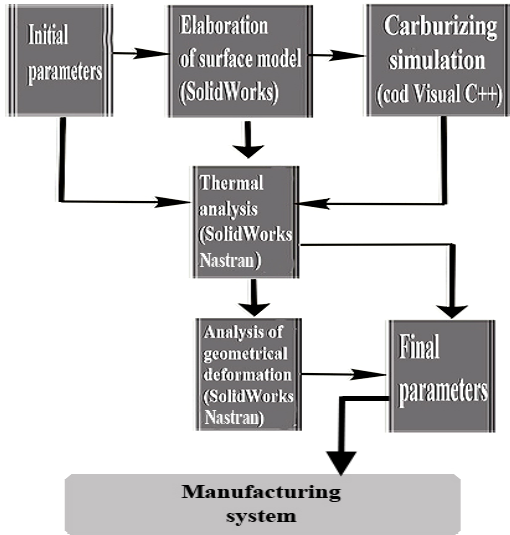

Fig. 3 Mathematical model of geometrical and thermal analysis for hollow rollers

Research has been conducted to an alternative roller structural form, hollow roller with different hollowness which is more flexible when responding to variations of bearing loads, and it should have less strict requirements on manufacturing precision. To achieve the logarithmic profile and exponential profile, high manufacturing precision is required. For the hollow roller the profile remains cylindrical. There are two ways by which contact-stress distributions can be influenced: the surface geometry of the roller and the stiffness of the roller. The elasticity to the roller ends decrease contact-stress in this section. The end-stress concentration can be reduced by using hollow rollers. FEM analysis was made to evaluate the design concept of the hollow roller and comparing it with traditional solid profiles of rollers.

In the simulation was considered an uniform load. The rolling element fatigue life [9],[10] is inversely proportional to the maximum stress to the ninth power (Lundberg-Palmgren) (11) or Zaretsky equation (12).

$$L \approx \left(\frac{1}{\sigma_{max}} \right)^9 \tag{11}$$

$$L = A \left(\frac{1}{\tau} \right)^c e \left(\frac{1}{V} \right)^{\frac{1}{e}} \approx \frac{1}{\sigma_{max}^n} \tag{12}$$

where:

- A is a constant factor of material;
- τ is critical shear stress;
- c/e is Lundberg-Palmgren parameter (val. 9);
- e is Weibull slope (val.1.1);
- V is elemental volume;
- S_{max} is maximum Hertz stress;
- n is Hertz stress life exponent (val. 9...12).

Barnsby starting from the Ioannides-Harris theory [11], introduces the stress factor K_c .

$$K_c = 1 + \left(1 - C_L^{\frac{4}{L}} \right) \frac{\sigma_{VM,lim}}{\sigma_{VM,max}} \tag{13}$$

where:

- $\sigma_{VM,lim}$ is fatigue limit of Von Mises stress;
- $\sigma_{VM,max}$ is maximum of Von Mises stress;
- C_L is lubricant parameter.

In this research was used for simulate the compoment of rollers, Von Mises stress criterion. Nastran software found all stress components on each point and the results are conform with Von Mises stress equation [12]:

$$\alpha_{VM} = \frac{1}{\sqrt{2}} \sqrt{(\sigma_x - \sigma_y)^2 + (\sigma_y - \sigma_z)^2 + (\sigma_z - \sigma_x)^2 + 6(\tau_{xy}^2 + \tau_{yz}^2 + \tau_{zx}^2)} \tag{14}$$

The magnitude of uniform load-distribution used for the analysis is 275 KN. Distributions of maximum Von Mises stresses are shown for solid cylindrical roller (Fig.4), hollow roller with $D_i=80mm$ (Fig.5) and hollow roller with $D_i=100mm$ (fig.6).

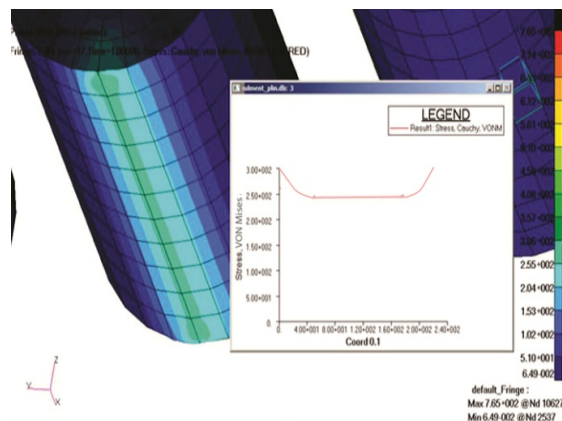

Fig. 4 Von Mises stress chart for solid cylindrical roller [Mpa]

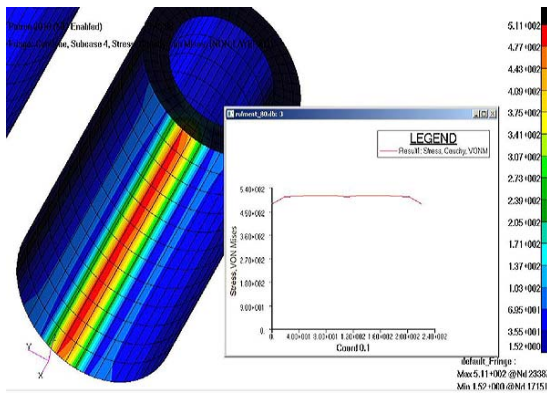

Fig. 5 Von Mises stress chart for hollow cylindrical roller with $D_i=80\text{mm}$ [MPa]

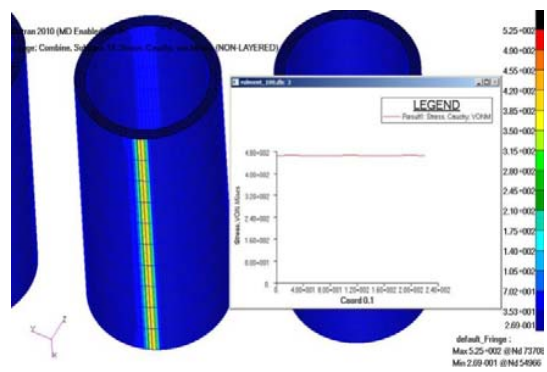

Fig. 6 Von Mises stress chart for hollow cylindrical roller with $D_i=100\text{mm}$ [MPa]

The research was conducted taking into account the real radial force of a wind power plant but the calculation was made on a single row bearing with cylindrical roller. In reality, these bearings are used rarely, generally using the bearings on two or four rows.

Nastran defines the stress line by interpolating between the two endpoints to obtain a user-specified number of equal intervals along a straight line. The specified stress results are obtained at equally spaced intervals along the line in a local coordinate system defined by the line. Nastran uses the endpoints of the saved path as the endpoints of the stress line, [12]. The distributions of stresses and maximum Von Mises stresses are similar for the solid cylindrical rollers, the critical stresses acting to the both ends. In case of solid spherical roller, the stress to the ends decrease but the conditions of manufacturing is very strict and more expensive.

Attempts with roller bearings whose cavity exceeds $D_i > 100\text{mm}$ were not made for obvious reasons. As shown, carburization depth is the largest end the wall of rollers will become too thin. Also, in fig.7 is observed logarithmic increase of deformation with cavity increasing.

The research clearly shows that different hollow rollers, tested in simulations, not only reduces the inertial mass, but behave as good in deformations and much better in the contact stress.

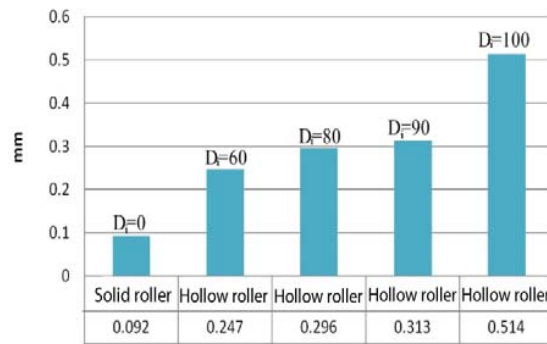

Fig. 7 Graph of deformations of bearing depending of hollowness- results obtained by finite element analysis

In Figure 7 and Figure 8 can see the increasing of strains on the basis of the cavity. It is noted that this increase is lower for a bearing with outer diameter $D = 1900\text{mm}$.

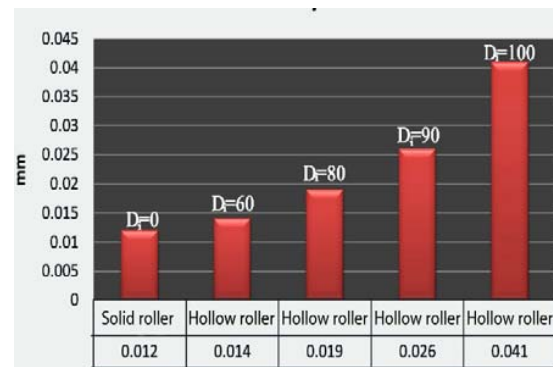

Fig. 8 Graph of deformations of roller depending of hollowness- results obtained by finite element analysis

V. CONCLUSION

The results of Nastran FEM for the Von Mises stress distributions for the hollow cylindrical roller under identical loads are interesting. Due to increased elasticity to the ends of hollow roller, the Von Mises stress decrease, the graphic being constant. Under the same conditions, the stress caused by the contact between the race and the hollow roller is less than the stress caused by the contact between the race and the solid roller. Further, FEM simulation shows that a stress concentration occurs at the ends of solid cylindrical roller but for the hollow roller the stress concentration is the same on the entire length. The result may indicate that for certain range of the roller geometry the use of hollow rollers will not weaken the strength of the bearing, on the contrary, increased its sustainability. In addition, about 50% of roller weight of a bearing could be reduced due to the introduction of the hollowness. FEM analyses demonstrate that the roller would render superior performance which could enable the elimination of the stresses at the ends of the roller. As a result, the roller could function similarly to a logarithmic-profile roller, but the manufacturing procedures of the roller are

simplified.[15],[16] The bearings with hollow rollers have advantages such as reduction of the inertial loads, weight reduction, material saving. In implementing a flexible manufacturing system configuration it has to be found a configuration to satisfy both the economic and technical requirements imposed on the system.[17],[18] These requirements are associated inputs (operating costs and capital expenditures) and outputs (production quantity) of a FMS. Configuration that best meets the objectives of introducing a flexible manufacturing system to be found in the set of alternatives defined and evaluated. Future work should be more focused on the practical use of these methodologies but also on the developing of new methods for the analysis of the efficiency of the technological transfer, in the context of new world of IT and automation. The flexible manufacturing system (FMS) does not constitute the present universal solution – a universal recipe, applicable in any conditions. The flexible manufacturing system is a solution, although specific to a defined task, in predetermined conditions, with a low prevision and determinism level, and consequently a scope-oriented solution.

REFERENCES

- [1] J. Morren, J. Pierik, W.H. de Haan, Inertial response of variable speed wind turbines *Electric Power Systems Research* 76-2006, pag.980–987.
- [2] Y. D. Song, B. Dhinakaran, X. Y. Bao, Variable speed control of wind turbines using nonlinear and adaptive algorithms, *Journal of Wind Engineering and Industrial Aerodynamics* 85-2000, pag.293-308.
- [3] W. M. Abu Jadayil, N. M. Jaber, Numerical prediction of optimum hollowness and material of hollow rollers under combined loading, *Materials and Design Journal* 31-2010, pag.1490–1496.
- [4] S. Barabas, C. Serban, Deep carburizing process for 20NiCrMo7 and 15 NiCr13 steels used in construction of large bearings elements, *AFASES 2010 Conference - Scientific Research and Education in the Air Force*, 27-29 May, 2010, Brasov, pag.594-598.
- [5] O. Zwirlein, H. Schlicht, Rolling contact fatigue mechanism accelerated testing versus field performance, *Rolling Contact Fatigue Testing of Bearing Steels*, ASTM STP 771, 1982, pag.358-379.
- [6] H. Reusner, The logarithmic roller profile –the key to superior performance of cylindrical and taper roller bearings, *Ball Bearing Journal* 230-1987, pag. 2–10.
- [7] S.H. Ju, T.L. Horng, K.C. Cha, Comparisons of contact pressures of crowned rollers, *Proceedings of the Institution of Mechanical Engineering Part 1, Engineering Tribology Journal*, 214-2000, pag. 147–156.
- [8] Cao, M., Xiao, J., "A comprehensive dynamic model of double-row spherical roller bearing—Model development and case studies on surface defects, preloads, and radial clearance". *Mechanical Systems and Signal Processing* 22, 2008, pag. 467–489.
- [9] G. Lundberg, A. Palmgren, Dynamic Capacity of Rolling Bearings, *Acta Polytechnica Scandinavica. Electrical Engineering Series*, vol. 1, no. 3, 1947, pag. 87-89.
- [10] E. V. Zaretsky, J. V. Poplawski, S. M. Peters, Comparison Of Life Theories For Rolling-Element Bearings, *NASA Technical Memorandum 106585 Annual Meeting of the Society of Tribologists and Lubrication Engineers*, Chicago, Illinois, May 14-19, 1995, pag.5-9.
- [11] M. Howell, G.T. Hahn, C.A. Rubin, D.L. McDowell, Finite element analysis of rolling contact for nonlinear kinematic hardening bearing steel, *ASME Journal Tribology*, 1995, pag. 36.
- [12] *MSC NASTRAN Release Guide*, 2005.
- [13] *Wind Energy—The Facts, Technology*, The European Wind Association, vol. 1, 2003, pag.43-47.
- [14] Beno, B., *Manufacturing: Design, Production, Automation and Integration*, Marcel Dekker, ISBN: 0-8247-4273-7, New York, NY, USA, 2003.
- [15] Fota, A., *Machine systems design. Modelling and simulation*, Transilvania University Publishing House, Brasov, Romania, 2004.
- [16] Kal-Pakjian, S., *Manufacturing Engineering and Technology*, Addison-Wesley Publishing Company, 1995.
- [17] Malta, A. & Semeraro, Q., *Design of Advanced Manufacturing Systems*, Springer Verlag, Berlin. 2005.
- [18] Shivanand, M. K., Benal, M. M. & Koti, V., *Flexible Manufacturing Systems*, Editor: New Age International, ISBN 8122418708, 9788122418705, 2006.